



PLAN ENDORSED FOR IN-PRINCIPLE APPROVAL

SEE LETTER E-126057-181622

REVIEWED



14-SEP-2021



**COCHIN SHIPYARD - CT3250**  
**50 T BOLLARD PULL ASD TUG -**  
**PRELIMINARY STABILITY REPORT**

*This design was developed by Cochin Shipyard Ltd. for Indian Ports Association as a part of ASTDS Package. CSL does not make any representation or warranties, express or implied as to the completeness, accuracy, suitability of the design and it shall be the responsibility of the respective builder/end-user to make its own assessment/evaluation of any such completeness, accuracy, suitability of the design prior to construction and any consequence thereof.*

Revision No.	Date	Description	Sign
Rev. I	13 Sep 2021	For publishing on IPA website	ABK/HUR



## TABLE OF CONTENTS

1. INTRODUCTION.....	1-1
2. VESSEL INFORMATION.....	2-1
3. INTACT STABILITY CRITERIA.....	3-1
4. GENERAL ARRANGEMENT.....	4-1
5. TOW POINT LOCATIONS.....	5-1
6. EXTERNAL FIFI ARRANGEMENT.....	6-1
7. OPENINGS.....	7-1
8. TANK PLAN.....	8-1
9. HYDROSTATIC DATA.....	9-1
10. CROSS CURVES.....	10-1
11. LOADING CONDITIONS.....	11-1



## 1. INTRODUCTION

This document summarizes the preliminary assessment of Intact Stability of 50 T Bollard Pull Tug variant for in-principle approval from Class. The stability of the vessel is checked against the requirement as per Intact Stability Code 2008.

Stability of the vessel during towing operation is checked as per amendment to part B of IS Code 2008, vide MSC Resolution 415(97), Section 2.8 – Ships Engaged in Towing Operations.

Stability of the vessel during FiFi operation is checked as per DNV RU-Ship, Part 5, Chapter 10, Section 9. Overturning moment is calculated assuming that all the fire monitors are operated at their full capacity in transverse direction.

Only most onerous conditions are described in this stability report. Detailed stability booklet including all the necessary loading conditions, hydrostatics, cross curves etc. to the satisfaction of Class and regulatory authorities shall be submitted to class for approval by the builder during the time of vessel construction.

Stability calculations are performed in NAPA 2020.2-1 software.



## 2. VESSEL INFORMATION

The vessel shall be primarily tasked for ship handling and towing operations including berthing/unberthing, push/pull, etc. within harbor.

The vessel shall operate within 12 nm from the shoreline.

The vessel shall have a static bollard pull of at least 50 tonnes at 100 % MCR of the engine in ahead condition.

### Main Particulars

Length overall	abt. 32.0 m
Length between perpendiculars	abt. 30.8 m
Breadth moulded	abt. 10.50 m
Depth midships	abt. 5.0 m
Hull Draught	abt. 3.7 m
Max. Draught	abt. 4.3 m
Gross tonnage	<500 GT
Complement	10 Nos.
Class Notation	☞ SUL, ☞ IY, TUG, INDIAN RIVER SEA VESSEL TYPE-4



### 3. INTACT STABILITY CRITERIA

#### 3.1. GENERAL CRITERIA (as per IS Code 2008 Ch. 2, 2.2)

- The area under the righting lever curve (GZ curve) shall not be less than 0.055 m-rad up to  $= 30^\circ$
- Area under GZ Curve shall not be less than 0.09 m-rad up to  $40^\circ$  or the angle of down-flooding, whichever is lesser.
- Area under GZ Curve between the angles of heel of  $30^\circ$  and lesser of  $40^\circ$  or the angle of down-flooding shall not be less than 0.03 m-rad.
- The righting lever GZ shall be at least 0.2 m at an angle of heel equal to or greater than  $30^\circ$
- The initial metacentric height  $GM_0$  shall not be less than 0.15 m.
- The maximum righting lever shall occur at an angle of heel not less than  $25^\circ$ .

#### 3.2. SEVERE WIND AND ROLLING CRITERIA (as per IS Code 2008 Ch. 2, 2.3)

Ability of the ship to withstand combined effects of beam wind and rolling shall be demonstrated as follows, when subjected to wind loads as per IS Code Ch. 2, 2.3:

- Area b shall be equal to or greater than area a
- The angle of heel under action of steady wind should not exceed  $16^\circ$  or 80% of the angle of deck edge immersion, whichever is less.

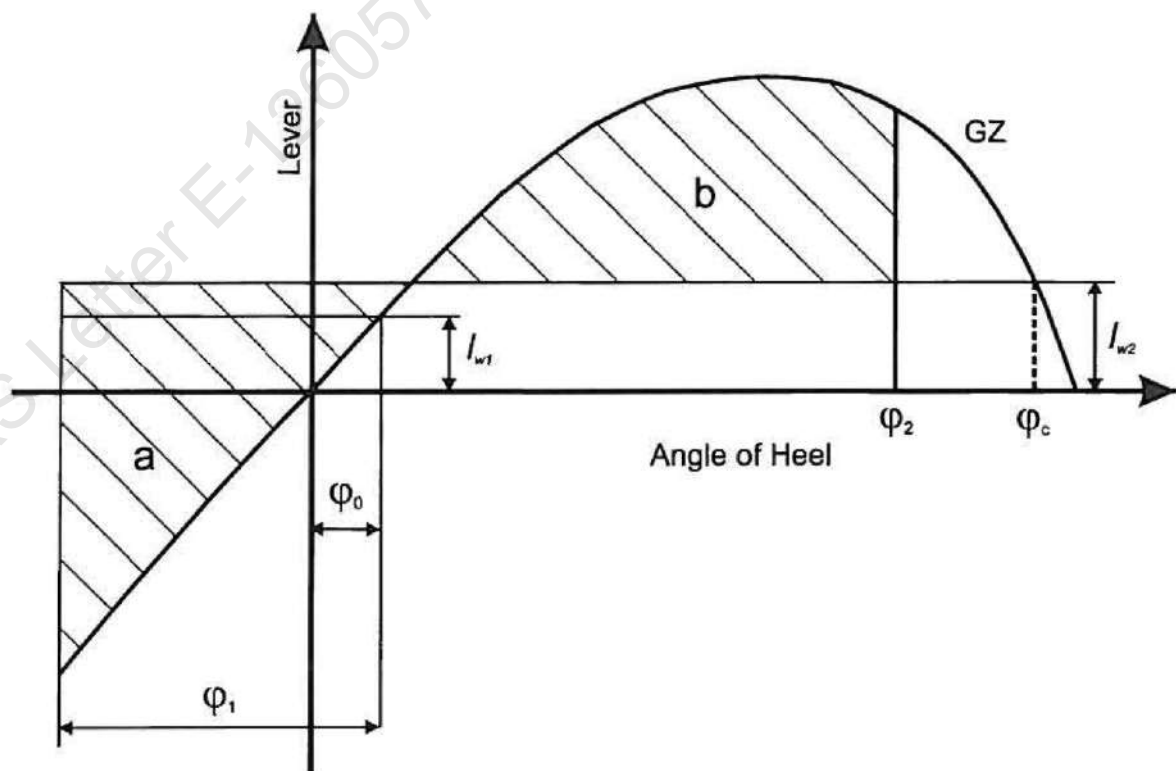

Figure 1 Severe Wind & Rolling Criteria



### 3.3. STABILITY CRITERIA FOR TOWING (as per IS Code 2008, Ch.2, 2.8)

Stability of the vessel during towing operation has been checked iaw IS Code 2008, Ch. 2, 2.8.

- The area A between the righting lever curve and the heeling lever curve for self-tripping calculated iaw. 2.8.2.1 of IS Code, measured from equilibrium heel angle, ( $\phi_e$ ) to the angle of the second intersection, ( $\phi_c$ ) or the angle of down-flooding, ( $\phi_f$ ) whichever is less, should be greater than the area B contained between the heeling lever curve and the righting lever curve, measured from the heel angle  $\phi=0$  to equilibrium heel angle ( $\phi_e$ ).
- The first intersection between the righting lever curve and the heeling lever curve for tow-tripping calculated iaw 2.8.2.2 should occur at an angle of heel less than the angle of down-flooding ( $\phi_f$ ).

Moment Calculation:

The location of propulsion units and towing point used for moment calculation are as indicated in Chapter 5-Tow Point.

#### a. Self-Tripping Heeling Lever

$$HL_{\phi} = \frac{BP \times C_T \times (h \times \cos\phi - r \times \sin\phi)}{g \times \Delta}$$

Where:

- BP bollard pull of the vessel in (kN) – 490.5 kN
- $C_T$  0.5, for ships with conventional, non-azimuth propulsion units;  
 $0.90/(1 + l/L_{LL})$  for ships with azimuth propulsion units installed at a single point along the length.  
 $C_T$  should not be less than 0.7 for ships with azimuth stern drive towing over the stern or tractor tugs towing over the bow, and not less than 0.5 for ships with azimuth stern drive towing over the bow or tractor tugs towing over the stern;
- $\Delta$  displacement, in (t);
- $l$  longitudinal distance, in (m), between the towing point and the vertical centreline of the propulsion unit(s) relevant to the towing situation considered;
- $h$  vertical distance, in (m), between the towing point and the horizontal centreline of the propulsion unit(s) as relevant for the towing situation considered;
- $g$  gravitational acceleration, in ( $m/s^2$ ), to be taken as 9.81;
- $r$  transverse distance, in (m), between the centre line and the towing point, to be taken as zero when the towing point is at the centre line.
- $L_{LL}$  length (L) as defined in the International Convention on Load Lines in force.

#### b. Tow Tripping Heeling Lever

$$HL_{\phi} = \frac{C_1 \times C_2 \times \gamma \times V^2 \times A_p \times (h \times \cos\phi - r \times \sin\phi + C_3 \times d)}{2 \times g \times \Delta}$$

Where:

- $C_1$  Lateral traction coefficient-  $2.8 \frac{L_S}{L_{PP}} - 0.1$   $0.10 \leq C_1 \leq 1.00$
- $C_2$  Correction of  $C_1$  for angle of heel =  $\frac{\phi}{3 \phi_D} + 0.5$   $C_2 \geq 1.00$
- $\phi_D$  Angle to deck edge =  $\tan^{-1} \frac{2f}{B}$



$C_3$	Distance from the center of $A_p$ to the waterline as fraction of the draught related to the heeling angle = $\frac{\varphi}{\varphi_D} \times 0.26 + 0.30$ , $0.50 \leq C_3 \leq 0.83$
$\gamma$	Specific gravity of water, in (t/m <sup>3</sup> );
$V$	Lateral velocity, in (m/s), to be taken as 2.57 (5 knots);
$A_p$	Lateral projected area, in (m <sup>2</sup> ), of the underwater hull;
$r$	the transverse distance, in (m), between the center line and the towing point, to be taken as zero when the towing point is at the center line;
$L_S$	The longitudinal distance, in (m), from the aft perpendicular to the towing point;
$L_{PP}$	Length between perpendiculars, in (m);
$\varphi$	Angle of heel;
$f$	Freeboard amidship, in (m);
$B$	Moulded breadth, in (m);
$h$	Vertical distance, in (m), from the waterline to the towing point;
$d$	Actual mean draught, in (m);

#### 3.4. STABILITY CRITERIA FOR CRANE OPERATION (as per IS Code 2008, Ch.2, 2.9)

Stability of the vessel has been checked for a heeling moment calculated iaw IS Code 2.9.6, the vessel has to meet the below stability criteria, as per IS Code 2.9.7.

- The residual righting area below the righting lever and above the heeling lever curve between  $\phi_e$  and the lesser of 40° or the angle of the maximum residual righting lever should not be less than 0.080 m rad.
- The equilibrium angle is to be limited to 10 degrees or the angle of immersion of the highest continuous deck enclosing the watertight hull.

The heeling lever should be calculated using the following formulae:

$$HL_{\varphi} = \frac{P_L \times y \times \cos\varphi}{\Delta}$$

where:

$P_L$	vertical load, in (t), of the lift, 3 t
$y$	transverse distance, in (m), of the lift, 14.3 m.
$\varphi$	angle of heel;
$HL_{\varphi}$	the heeling lever, in (m) due to the lift at $\varphi$ ; and
$\Delta$	the displacement, in (t) of the ship with the load of the lift.



### 3.5. STABILITY CRITERIA DURING EXTERNAL FIFI OPERATIONS (as per DNV GL, Rules for Fire Fighters)

Stability of the vessel during FiFi operation is checked as per DNV Part 5 Ch.10. Section 9, 9.1.3.

The monitor heeling lever (F), shall be less 0.5 times the maximum GZ corresponding to maximum allowable VCG. If the maximum GZ occurs after 30°, the GZ at 30° shall be used instead of the maximum GZ.

Heeling moment is calculated with all the fire monitors operating at their full capacity in transverse direction. The calculation is as below:

$$HL = \frac{F \times a}{\Delta}$$

- F heeling force, assumed in transverse direction based on the full capacity of the fire monitors,  $n \times R$
- n Number of monitors, 2 Nos.
- R Reaction force from one monitor, when operating in transverse direction, 9.2 kN\*
- a Monitor heeling arm, taken as the vertical distance between the centre of the thruster and the centreline of the monitor, 10.385 m

\* Indicative Reaction force from monitor - Estimated based available data at this point. The builder/designer to estimate actual reaction based on binding data from OEMs during construction stage.



---

#### 4. GENERAL ARRANGEMENT

Ref. drawing number CT3250-101-001 General Arrangement.

Refer IRS Letter E-126057-181622 dated, September 14, 2021





**6. EXTERNAL FIFI ARRANGEMENT**

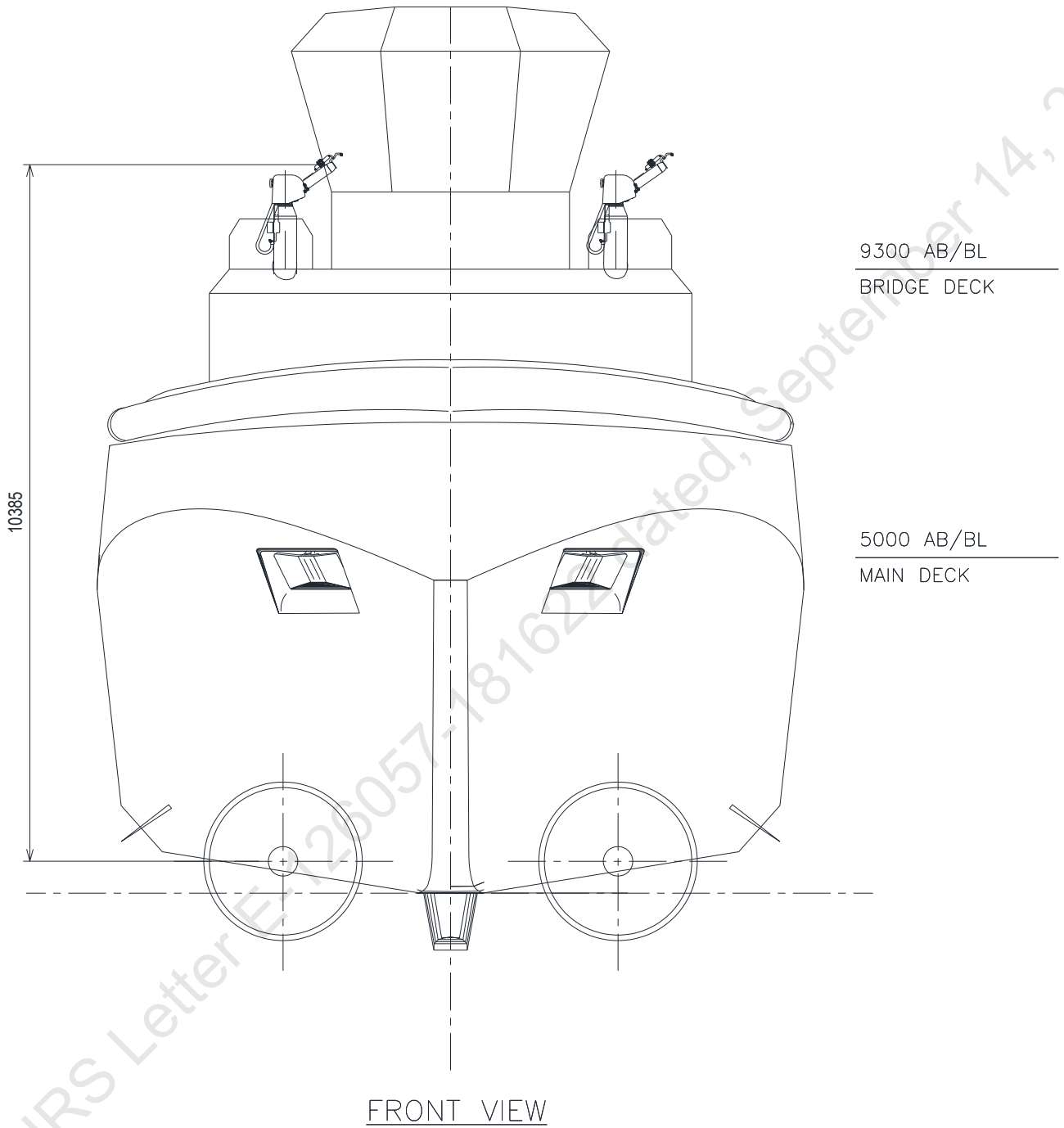



## 7. OPENINGS

The position of the lower corner farthest from the centreline of the ER ventilation are as below:

Name	Length to Fr. 0 [m]	Dist. From C.L [m]	Height from Baseline [m]	Opening Type
ER – Supply “PS/SB”	12.75	2.3	5.9	Unprotected
ER – Out “PS/SB”	14.0	2.3	7.9	Unprotected

Note:

Openings required for continuous supply to Engine room which are not conforming to ICLL Reg. 17(3) may be accepted subject to provision of alternate arrangements below and concurrence of flag.

- Shall be considered as unprotected openings in the stability calculation.
- Suitable weathertight closing arrangements shall be provided for the ventilators.
- Louvre shall have a coaming height of not less than 900 mm above main deck.
- Suitable drain shall be provided in way of the ventilators.

It shall be the responsibility of the respective builder/designer to get approval from Class/Flag for the alternate arrangements for lower coaming heights.



**8. TANK PLAN**

Refer IRS Letter E-126057-181622 dated, September 14, 2021



9 HYDROSTATIC DATA

MAIN CHARACTERISTICS OF THE VESSEL:

-----

Length between perpendiculars	30.84	m
Breadth (moulded)	10.50	m
Design draught (moulded)	3.70	m
X-coordinate of aft perpendicular	0.31	m
X-coordinate of reference point (XREF)	15.73	m
X-coordinate of midship section (XMID)	16.19	m
Thickness of keelplate	0.012	m
Mean thickness of shell plating	0.010	m
Seawater density	1.025	ton/m3

Calculations are based on STABHULL date 2021-08-10 time 09:57

Shell thickness used in the calculation	10.0	mm
X-coord. of aft end of DWL	0.31	m
X-coord. of fore end of DWL	31.15	m
Calc. sections	58	
Plate thickness	10.0	mm

EXPLANATION OF SYMBOLS:

-----

T	Draught (moulded)	m
TK	Draught below keel	m
DISP	Total displacement	t
LCB	longitudinal centre of buoyancy	m
VCB	Vertical center of buoyancy	m
LCF	Longitudinal centre of flotation	m
KMT	Transverse metacentric height	m
MCT	Moment to change trim	tm/cm
TPC	change of displacement/change of draught	t/cm
Trim by BOW : +ve		
X = 0 at TRANSOM		

-----

Trim: 0 m

T m	TK m	DISP t	LCB m	VCB m	LCF m	KMT m	MCT tm/cm	TPC t/cm
3.000	3.012	502.0	16.249	1.862	14.925	5.851	5.2	2.7
3.050	3.062	515.5	16.214	1.892	14.913	5.812	5.3	2.7
3.100	3.112	529.0	16.181	1.923	14.905	5.777	5.3	2.7
3.150	3.162	542.7	16.148	1.953	14.896	5.745	5.4	2.7
3.200	3.212	556.4	16.117	1.983	14.892	5.716	5.5	2.7
3.250	3.262	570.1	16.087	2.013	14.884	5.691	5.5	2.8
3.300	3.312	584.0	16.059	2.043	14.872	5.664	5.6	2.8
3.350	3.362	597.9	16.031	2.073	14.863	5.640	5.7	2.8
3.400	3.412	611.8	16.004	2.102	14.853	5.618	5.7	2.8
3.450	3.462	625.9	15.978	2.132	14.845	5.598	5.8	2.8
3.500	3.512	640.0	15.953	2.162	14.837	5.581	5.8	2.8
3.550	3.562	654.2	15.929	2.191	14.832	5.564	5.9	2.8
3.600	3.612	668.4	15.905	2.221	14.819	5.550	6.0	2.9
3.650	3.662	682.7	15.882	2.250	14.811	5.537	6.0	2.9
3.700	3.712	697.1	15.860	2.280	14.800	5.525	6.1	2.9
3.750	3.762	711.5	15.839	2.309	14.793	5.513	6.2	2.9
3.800	3.812	726.0	15.818	2.338	14.788	5.502	6.2	2.9
3.850	3.862	740.6	15.797	2.367	14.781	5.493	6.3	2.9
3.900	3.912	755.2	15.778	2.397	14.775	5.486	6.4	2.9
3.950	3.962	769.9	15.758	2.426	14.769	5.479	6.4	2.9
4.000	4.012	784.7	15.740	2.455	14.766	5.472	6.5	3.0
4.050	4.062	799.5	15.722	2.484	14.763	5.467	6.5	3.0
4.100	4.112	814.4	15.704	2.513	14.764	5.461	6.6	3.0
4.150	4.162	829.3	15.687	2.542	14.779	5.455	6.6	3.0
4.200	4.212	844.3	15.671	2.571	14.794	5.451	6.7	3.0
4.250	4.262	859.3	15.656	2.600	14.808	5.448	6.7	3.0
4.300	4.312	874.4	15.642	2.629	14.823	5.445	6.8	3.0
4.350	4.362	889.5	15.628	2.658	14.838	5.444	6.8	3.0
4.400	4.412	904.6	15.615	2.686	14.853	5.443	6.8	3.0
4.450	4.462	919.8	15.602	2.715	14.869	5.441	6.9	3.0
4.500	4.512	935.0	15.591	2.744	14.885	5.439	6.9	3.1

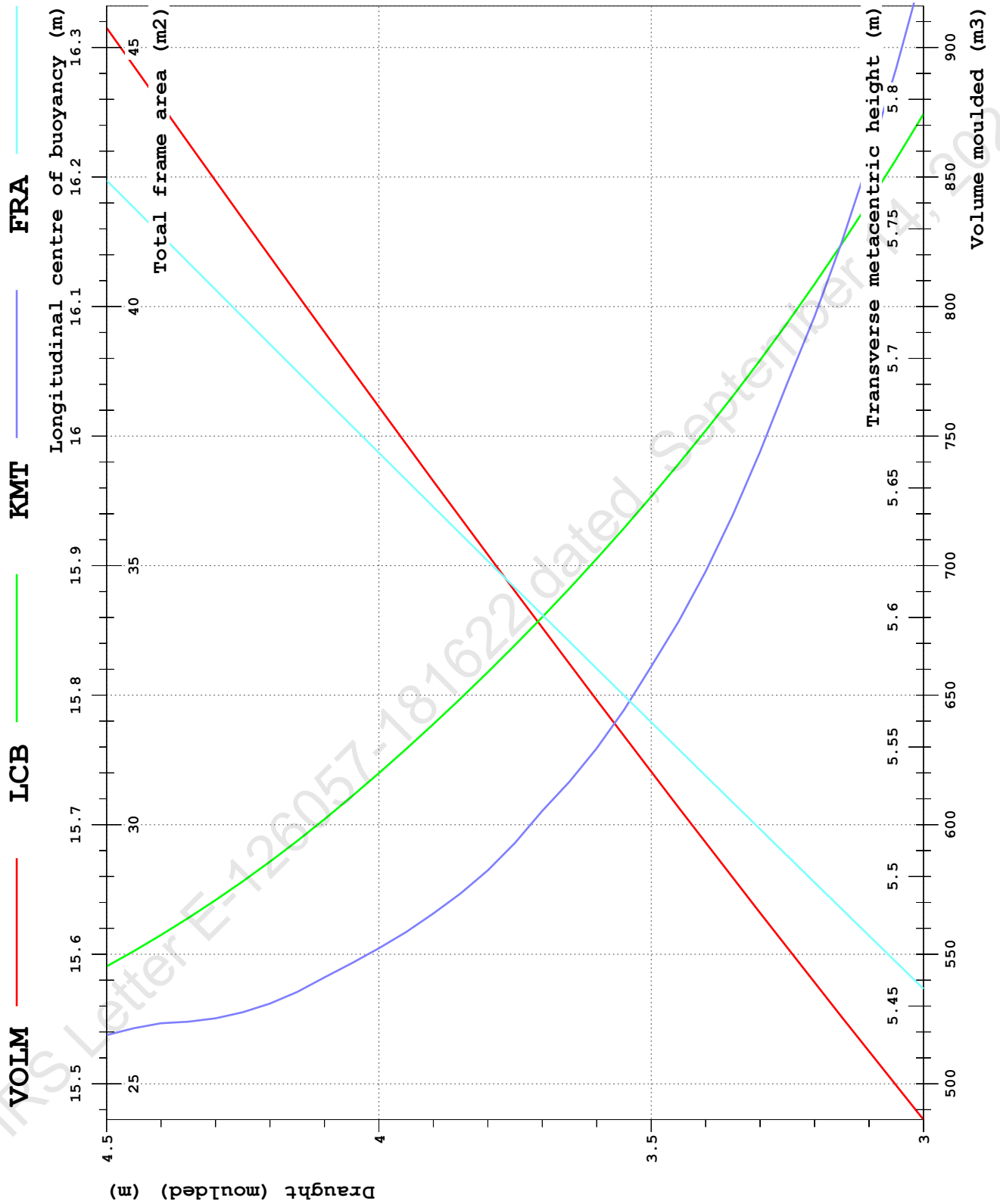

Trim: -0.6 m

T m	TK m	DISP t	LCB m	VCB m	LCF m	KMT m	MCT tm/cm	TPC t/cm
3.000	3.012	507.0	15.615	1.879	14.615	5.883	5.2	2.7
3.050	3.062	520.6	15.589	1.910	14.607	5.846	5.3	2.7
3.100	3.112	534.2	15.565	1.940	14.602	5.810	5.4	2.7
3.150	3.162	547.9	15.541	1.970	14.604	5.777	5.5	2.7
3.200	3.212	561.6	15.518	2.000	14.602	5.747	5.5	2.8
3.250	3.262	575.5	15.495	2.030	14.596	5.720	5.6	2.8
3.300	3.312	589.4	15.474	2.060	14.585	5.693	5.7	2.8
3.350	3.362	603.4	15.453	2.090	14.577	5.668	5.7	2.8
3.400	3.412	617.4	15.433	2.120	14.568	5.646	5.8	2.8
3.450	3.462	631.5	15.414	2.149	14.560	5.626	5.9	2.8
3.500	3.512	645.7	15.395	2.179	14.558	5.605	5.9	2.8
3.550	3.562	659.9	15.377	2.209	14.553	5.587	6.0	2.9
3.600	3.612	674.2	15.360	2.238	14.548	5.571	6.0	2.9
3.650	3.662	688.6	15.343	2.267	14.543	5.555	6.1	2.9
3.700	3.712	703.0	15.326	2.297	14.538	5.541	6.2	2.9
3.750	3.762	717.5	15.310	2.326	14.535	5.527	6.2	2.9
3.800	3.812	732.1	15.295	2.355	14.537	5.514	6.3	2.9
3.850	3.862	746.7	15.280	2.385	14.552	5.501	6.3	2.9
3.900	3.912	761.4	15.266	2.414	14.565	5.489	6.4	2.9
3.950	3.962	776.0	15.253	2.443	14.579	5.479	6.4	2.9
4.000	4.012	790.8	15.241	2.472	14.593	5.470	6.4	3.0
4.050	4.062	805.6	15.229	2.501	14.607	5.462	6.5	3.0
4.100	4.112	820.4	15.218	2.529	14.620	5.456	6.5	3.0
4.150	4.162	835.2	15.207	2.558	14.634	5.451	6.5	3.0
4.200	4.212	850.1	15.197	2.587	14.648	5.446	6.6	3.0
4.250	4.262	865.1	15.188	2.616	14.662	5.443	6.6	3.0
4.300	4.312	880.1	15.179	2.644	14.676	5.441	6.7	3.0
4.350	4.362	895.1	15.171	2.673	14.692	5.436	6.7	3.0
4.400	4.412	910.2	15.163	2.701	14.710	5.431	6.7	3.0
4.450	4.462	925.3	15.156	2.730	14.729	5.426	6.8	3.0
4.500	4.512	940.4	15.149	2.758	14.749	5.421	6.8	3.0

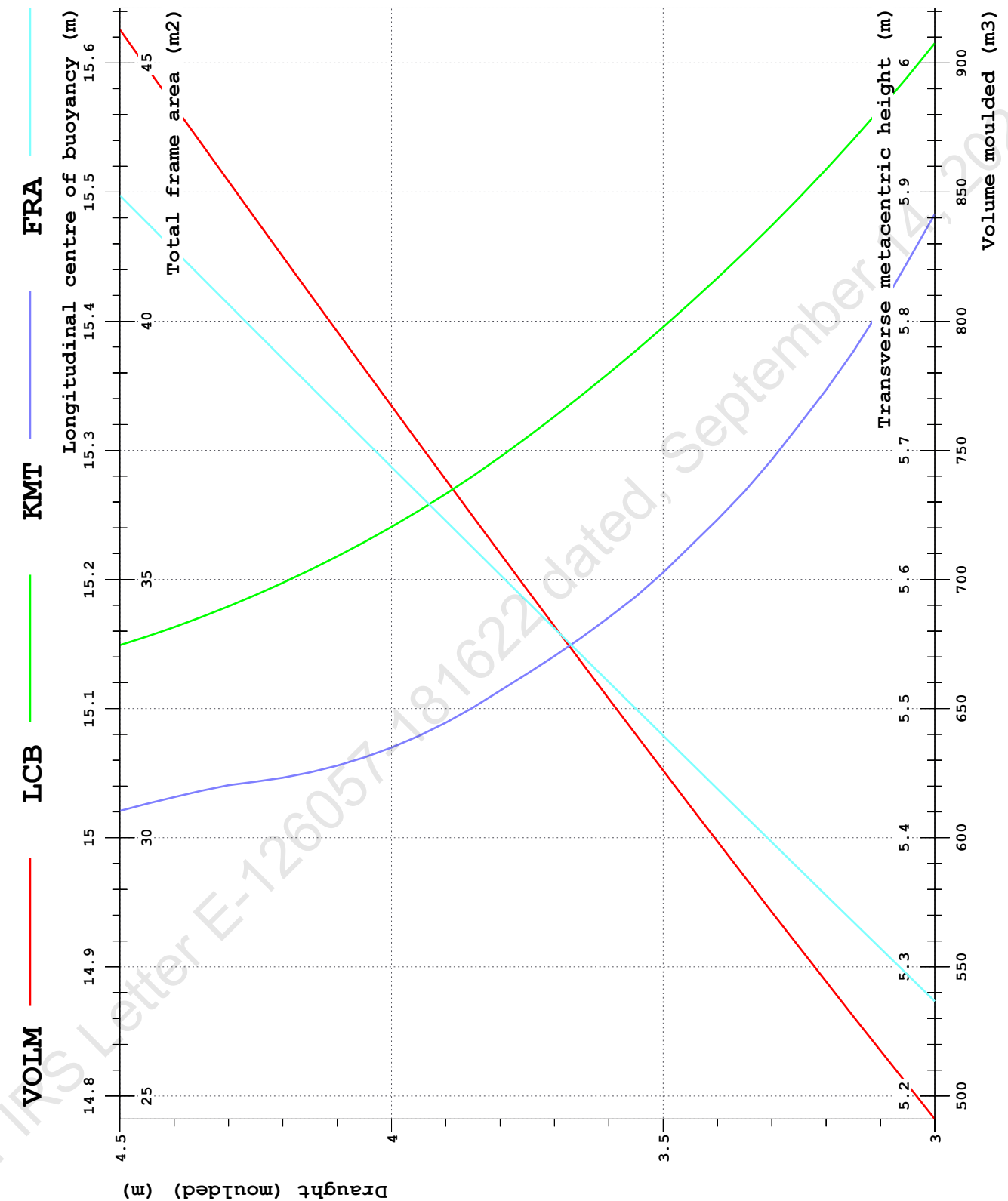

Trim: 0.6 m

T m	TK m	DISP t	LCB m	VCB m	LCF m	KMT m	MCT tm/cm	TPC t/cm
3.000	3.012	498.6	16.879	1.860	15.292	5.796	5.1	2.7
3.050	3.062	512.0	16.836	1.890	15.233	5.774	5.2	2.7
3.100	3.112	525.4	16.795	1.921	15.188	5.753	5.3	2.7
3.150	3.162	539.0	16.754	1.951	15.175	5.722	5.4	2.7
3.200	3.212	552.6	16.715	1.981	15.167	5.693	5.4	2.7
3.250	3.262	566.3	16.677	2.010	15.161	5.666	5.5	2.7
3.300	3.312	580.1	16.641	2.040	15.151	5.641	5.5	2.8
3.350	3.362	593.9	16.606	2.070	15.140	5.619	5.6	2.8
3.400	3.412	607.8	16.573	2.099	15.130	5.599	5.7	2.8
3.450	3.462	621.8	16.540	2.129	15.120	5.581	5.7	2.8
3.500	3.512	635.8	16.508	2.158	15.111	5.565	5.8	2.8
3.550	3.562	650.0	16.478	2.188	15.105	5.548	5.8	2.8
3.600	3.612	664.1	16.448	2.217	15.091	5.533	5.9	2.8
3.650	3.662	678.4	16.420	2.246	15.081	5.521	6.0	2.9
3.700	3.712	692.7	16.392	2.276	15.071	5.510	6.0	2.9
3.750	3.762	707.0	16.365	2.305	15.063	5.501	6.1	2.9
3.800	3.812	721.5	16.339	2.334	15.058	5.492	6.2	2.9
3.850	3.862	736.0	16.314	2.363	15.050	5.485	6.2	2.9
3.900	3.912	750.5	16.289	2.392	15.041	5.479	6.3	2.9
3.950	3.962	765.2	16.265	2.421	15.034	5.475	6.4	2.9
4.000	4.012	779.9	16.242	2.450	15.028	5.469	6.4	2.9
4.050	4.062	794.7	16.219	2.479	15.023	5.465	6.5	3.0
4.100	4.112	809.5	16.197	2.508	15.018	5.462	6.6	3.0
4.150	4.162	824.4	16.176	2.537	15.013	5.460	6.6	3.0
4.200	4.212	839.4	16.155	2.566	15.009	5.459	6.7	3.0
4.250	4.262	854.4	16.135	2.595	15.006	5.458	6.8	3.0
4.300	4.312	869.5	16.115	2.624	15.004	5.458	6.8	3.0
4.350	4.362	884.7	16.096	2.653	15.003	5.458	6.9	3.0
4.400	4.412	899.9	16.078	2.682	15.004	5.459	6.9	3.0
4.450	4.462	915.1	16.060	2.711	15.018	5.459	7.0	3.1
4.500	4.512	930.4	16.043	2.740	15.032	5.458	7.0	3.1

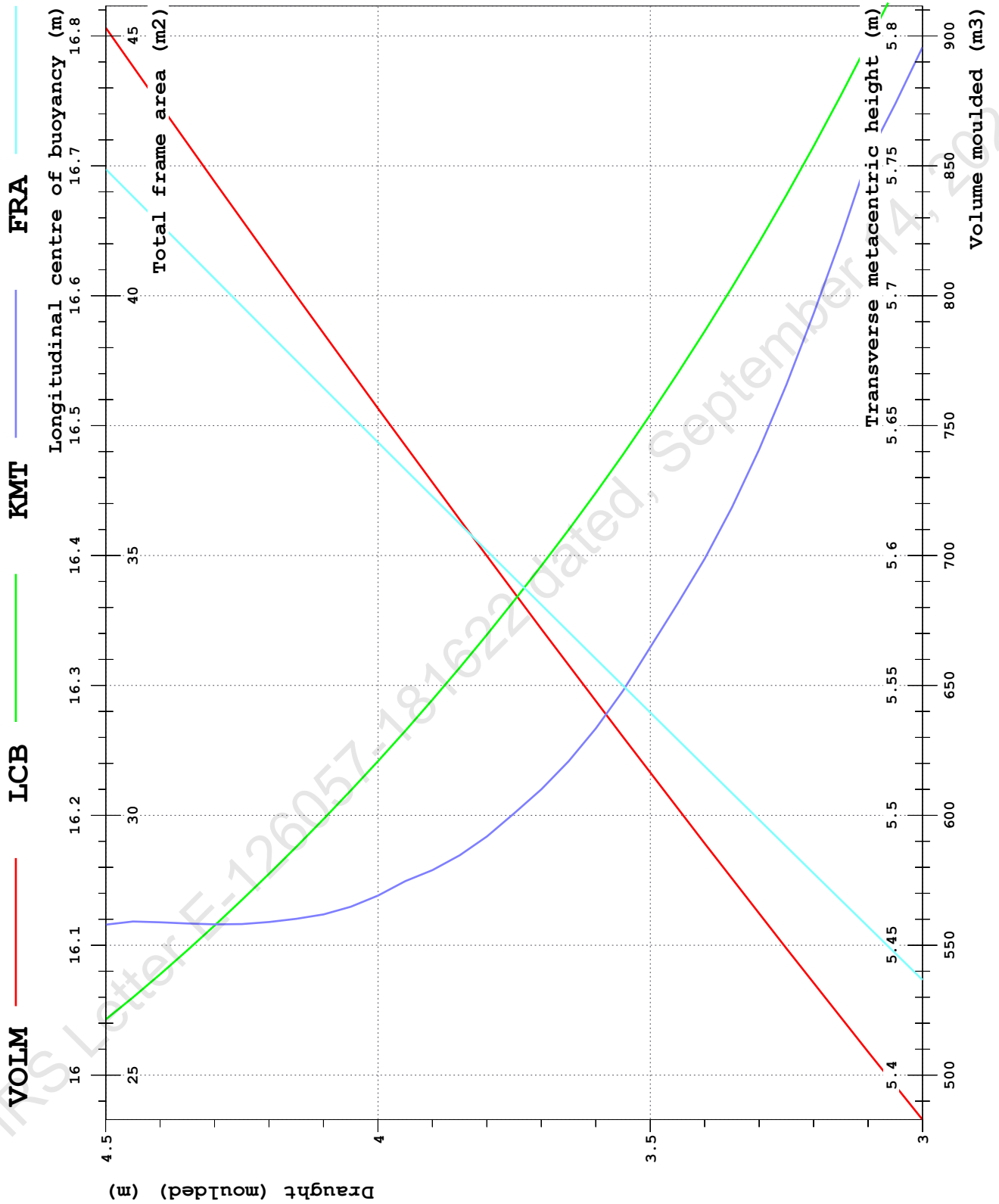

10 CROSS CURVES

Trim: 0 m

draught	KN (For Diff Heel Angles)							
	0.0	5.0	10.0	20.0	30.0	40.0	50.0	60.0
3.000	-0.007	0.504	1.012	2.012	2.882	3.489	3.867	4.042
3.050	-0.007	0.501	1.007	2.005	2.871	3.477	3.852	4.026
3.100	-0.006	0.498	1.002	1.998	2.859	3.465	3.836	4.009
3.150	-0.006	0.496	0.997	1.990	2.846	3.452	3.819	3.992
3.200	-0.006	0.493	0.993	1.983	2.833	3.438	3.802	3.975
3.250	-0.006	0.491	0.989	1.977	2.819	3.423	3.785	3.958
3.300	-0.006	0.489	0.985	1.969	2.805	3.407	3.767	3.941
3.350	-0.006	0.487	0.981	1.962	2.790	3.391	3.749	3.924
3.400	-0.006	0.485	0.977	1.954	2.774	3.374	3.731	3.906
3.450	-0.005	0.483	0.974	1.946	2.759	3.356	3.713	3.888
3.500	-0.005	0.482	0.971	1.938	2.743	3.337	3.694	3.871
3.550	-0.005	0.481	0.968	1.929	2.726	3.318	3.674	3.853
3.600	-0.005	0.479	0.965	1.919	2.709	3.298	3.655	3.835
3.650	-0.005	0.478	0.963	1.910	2.692	3.278	3.635	3.817
3.700	-0.005	0.477	0.961	1.900	2.675	3.257	3.614	3.799
3.750	-0.005	0.476	0.959	1.889	2.658	3.235	3.594	3.780
3.800	-0.005	0.476	0.957	1.878	2.640	3.213	3.573	3.762
3.850	-0.005	0.475	0.955	1.867	2.621	3.191	3.551	3.744
3.900	-0.005	0.474	0.953	1.855	2.603	3.167	3.530	3.725
3.950	-0.004	0.474	0.952	1.844	2.584	3.144	3.508	3.707
4.000	-0.004	0.473	0.950	1.831	2.564	3.120	3.485	3.688
4.050	-0.004	0.473	0.949	1.819	2.544	3.095	3.463	3.669
4.100	-0.004	0.472	0.948	1.806	2.523	3.070	3.439	3.650
4.150	-0.004	0.472	0.947	1.792	2.502	3.045	3.416	3.631
4.200	-0.004	0.472	0.945	1.779	2.481	3.019	3.392	3.611
4.250	-0.004	0.471	0.943	1.765	2.459	2.994	3.368	3.591
4.300	-0.004	0.471	0.940	1.751	2.438	2.968	3.344	3.572
4.350	-0.004	0.471	0.937	1.737	2.416	2.942	3.319	3.552
4.400	-0.004	0.470	0.933	1.723	2.394	2.916	3.294	3.531
4.450	-0.004	0.470	0.928	1.708	2.371	2.890	3.269	3.511
4.500	-0.004	0.470	0.922	1.693	2.349	2.864	3.244	3.490

Trim: 0 m

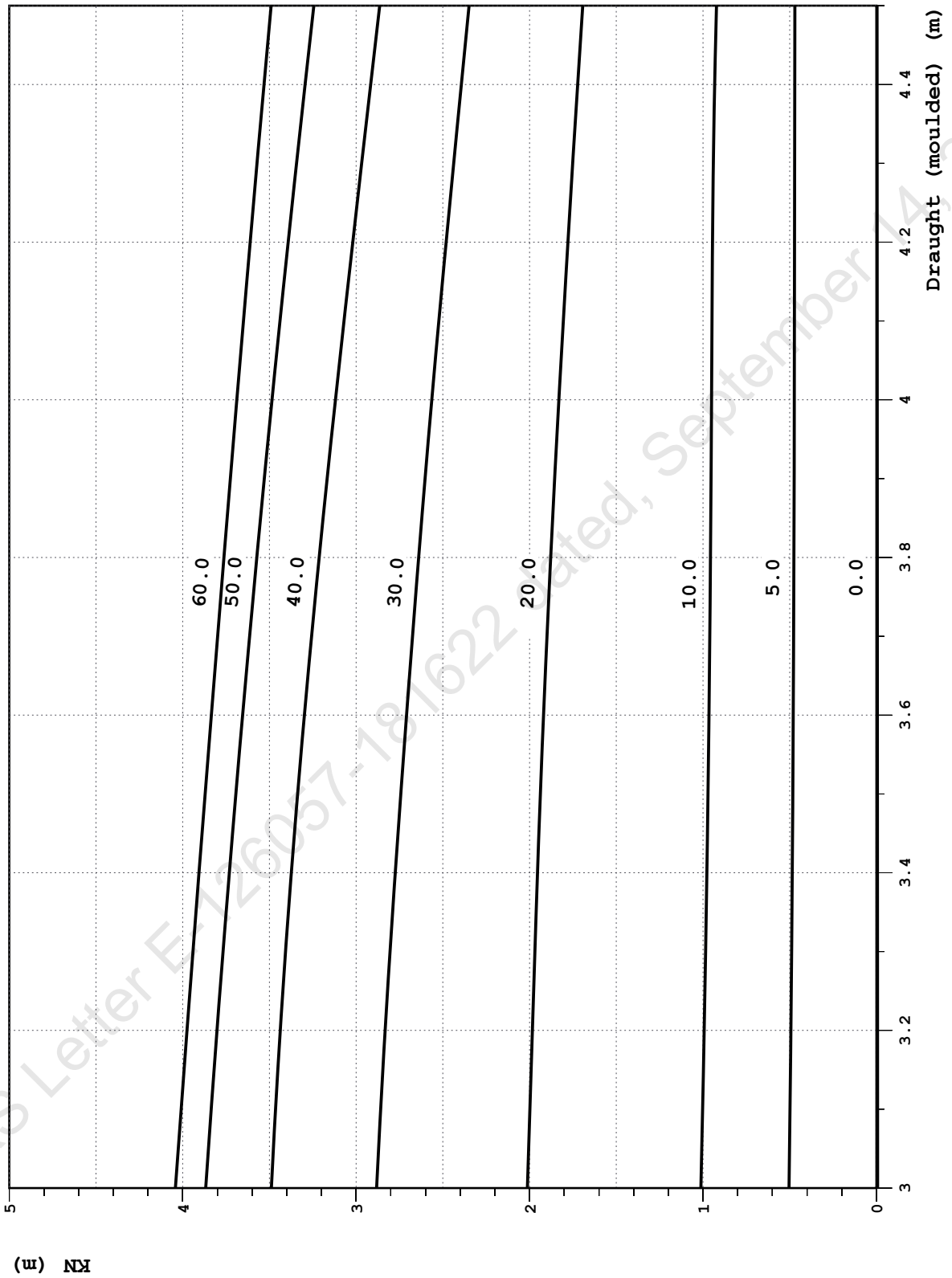

Trim: -0.6 m

draught	KN (For Diff Heel Angles)							
	0.0	5.0	10.0	20.0	30.0	40.0	50.0	60.0
3.000	-0.007	0.507	1.021	2.031	2.889	3.473	3.846	4.020
3.050	-0.007	0.504	1.015	2.022	2.875	3.459	3.829	4.003
3.100	-0.006	0.501	1.009	2.014	2.860	3.445	3.812	3.985
3.150	-0.006	0.498	1.004	2.006	2.844	3.429	3.794	3.967
3.200	-0.006	0.496	0.999	1.997	2.828	3.413	3.775	3.949
3.250	-0.006	0.493	0.994	1.989	2.811	3.396	3.756	3.931
3.300	-0.006	0.491	0.989	1.980	2.793	3.379	3.737	3.912
3.350	-0.006	0.489	0.985	1.970	2.775	3.360	3.718	3.894
3.400	-0.006	0.487	0.981	1.960	2.757	3.341	3.698	3.875
3.450	-0.005	0.486	0.978	1.950	2.738	3.322	3.678	3.857
3.500	-0.005	0.484	0.974	1.938	2.719	3.301	3.657	3.838
3.550	-0.005	0.482	0.971	1.927	2.700	3.281	3.637	3.819
3.600	-0.005	0.481	0.968	1.915	2.680	3.259	3.616	3.800
3.650	-0.005	0.480	0.965	1.903	2.660	3.237	3.594	3.781
3.700	-0.005	0.479	0.963	1.890	2.640	3.214	3.573	3.762
3.750	-0.005	0.478	0.960	1.877	2.620	3.191	3.551	3.743
3.800	-0.005	0.477	0.958	1.863	2.600	3.167	3.529	3.723
3.850	-0.005	0.476	0.956	1.849	2.579	3.143	3.506	3.704
3.900	-0.004	0.475	0.954	1.835	2.558	3.118	3.483	3.684
3.950	-0.004	0.474	0.952	1.821	2.537	3.093	3.460	3.665
4.000	-0.004	0.473	0.950	1.806	2.515	3.068	3.436	3.645
4.050	-0.004	0.473	0.949	1.791	2.494	3.042	3.412	3.625
4.100	-0.004	0.472	0.947	1.776	2.472	3.016	3.388	3.605
4.150	-0.004	0.471	0.945	1.761	2.449	2.990	3.364	3.585
4.200	-0.004	0.471	0.942	1.745	2.427	2.963	3.339	3.564
4.250	-0.004	0.470	0.938	1.729	2.405	2.937	3.314	3.544
4.300	-0.004	0.470	0.934	1.713	2.382	2.910	3.288	3.523
4.350	-0.004	0.470	0.928	1.697	2.359	2.883	3.263	3.502
4.400	-0.004	0.469	0.921	1.680	2.336	2.856	3.237	3.481
4.450	-0.004	0.469	0.914	1.663	2.313	2.829	3.210	3.460
4.500	-0.004	0.469	0.906	1.646	2.290	2.802	3.184	3.438

Trim: -0.6 m

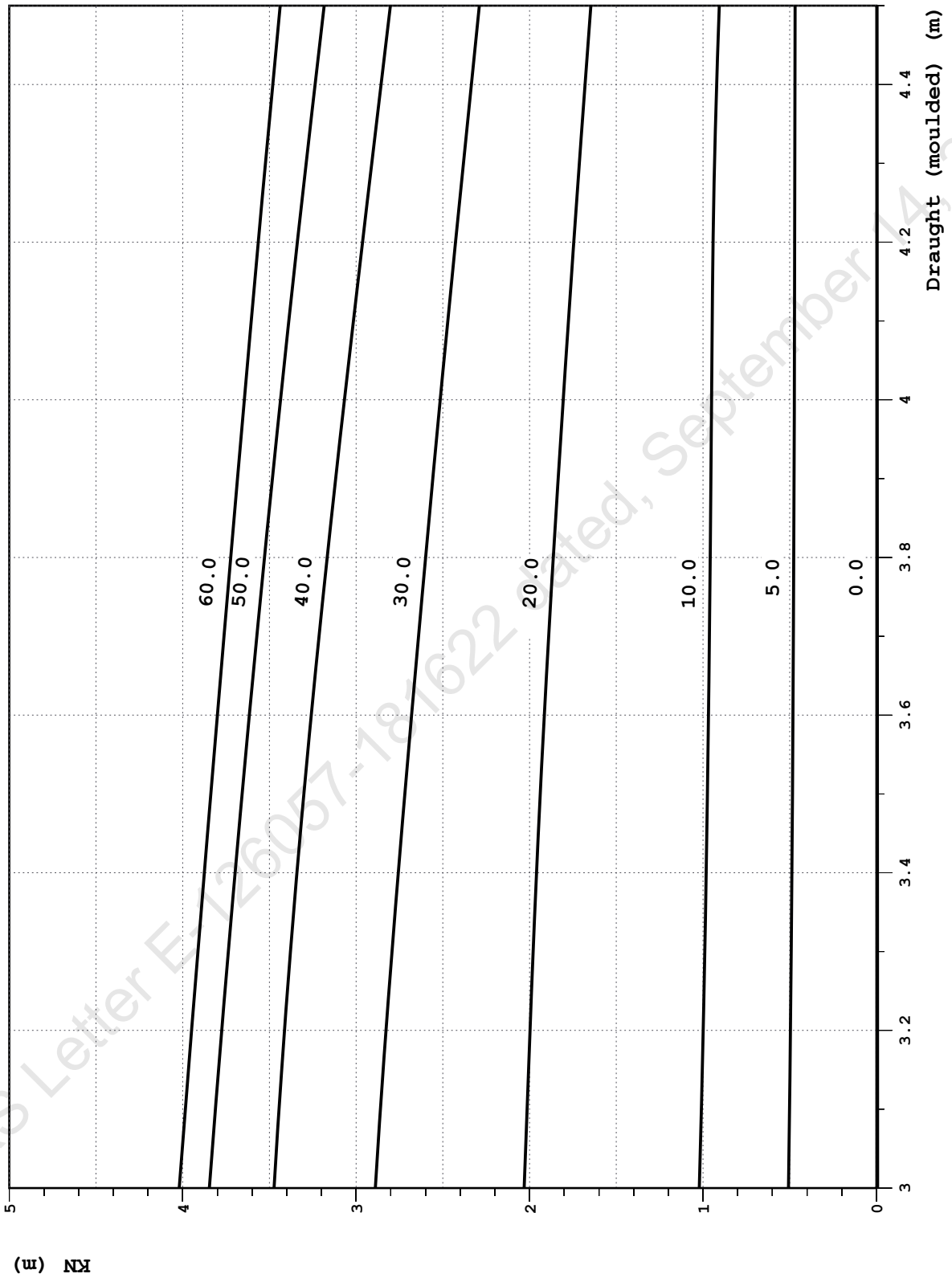

Trim: 0.6 m

draught	KN (For Diff Heel Angles)							
	0.0	5.0	10.0	20.0	30.0	40.0	50.0	60.0
3.000	-0.007	0.498	1.000	1.991	2.867	3.495	3.878	4.056
3.050	-0.007	0.496	0.996	1.985	2.859	3.485	3.864	4.040
3.100	-0.006	0.494	0.992	1.979	2.850	3.475	3.850	4.024
3.150	-0.006	0.492	0.989	1.973	2.840	3.464	3.835	4.009
3.200	-0.006	0.490	0.985	1.967	2.829	3.451	3.819	3.993
3.250	-0.006	0.488	0.982	1.961	2.818	3.438	3.803	3.977
3.300	-0.006	0.487	0.979	1.956	2.807	3.424	3.787	3.961
3.350	-0.006	0.485	0.976	1.950	2.795	3.410	3.771	3.944
3.400	-0.006	0.483	0.973	1.944	2.782	3.394	3.754	3.928
3.450	-0.005	0.482	0.970	1.937	2.769	3.378	3.736	3.911
3.500	-0.005	0.480	0.967	1.931	2.756	3.361	3.719	3.895
3.550	-0.005	0.479	0.965	1.924	2.742	3.343	3.701	3.878
3.600	-0.005	0.478	0.963	1.917	2.728	3.325	3.682	3.861
3.650	-0.005	0.477	0.961	1.909	2.714	3.306	3.664	3.844
3.700	-0.005	0.476	0.959	1.901	2.699	3.287	3.645	3.827
3.750	-0.005	0.475	0.957	1.893	2.684	3.267	3.625	3.809
3.800	-0.005	0.475	0.956	1.885	2.669	3.246	3.605	3.792
3.850	-0.005	0.474	0.954	1.876	2.652	3.225	3.585	3.775
3.900	-0.005	0.474	0.953	1.867	2.636	3.203	3.565	3.757
3.950	-0.004	0.473	0.951	1.857	2.618	3.181	3.544	3.740
4.000	-0.004	0.473	0.950	1.848	2.600	3.158	3.523	3.722
4.050	-0.004	0.473	0.949	1.837	2.582	3.135	3.501	3.704
4.100	-0.004	0.473	0.949	1.827	2.563	3.112	3.479	3.686
4.150	-0.004	0.472	0.948	1.816	2.543	3.088	3.457	3.667
4.200	-0.004	0.472	0.947	1.805	2.523	3.064	3.434	3.649
4.250	-0.004	0.472	0.945	1.794	2.503	3.040	3.411	3.630
4.300	-0.004	0.472	0.944	1.782	2.483	3.015	3.388	3.611
4.350	-0.004	0.472	0.941	1.770	2.462	2.990	3.364	3.592
4.400	-0.004	0.472	0.938	1.757	2.441	2.965	3.340	3.573
4.450	-0.004	0.472	0.935	1.745	2.419	2.940	3.316	3.553
4.500	-0.004	0.472	0.931	1.732	2.398	2.914	3.292	3.533

Trim: 0.6 m

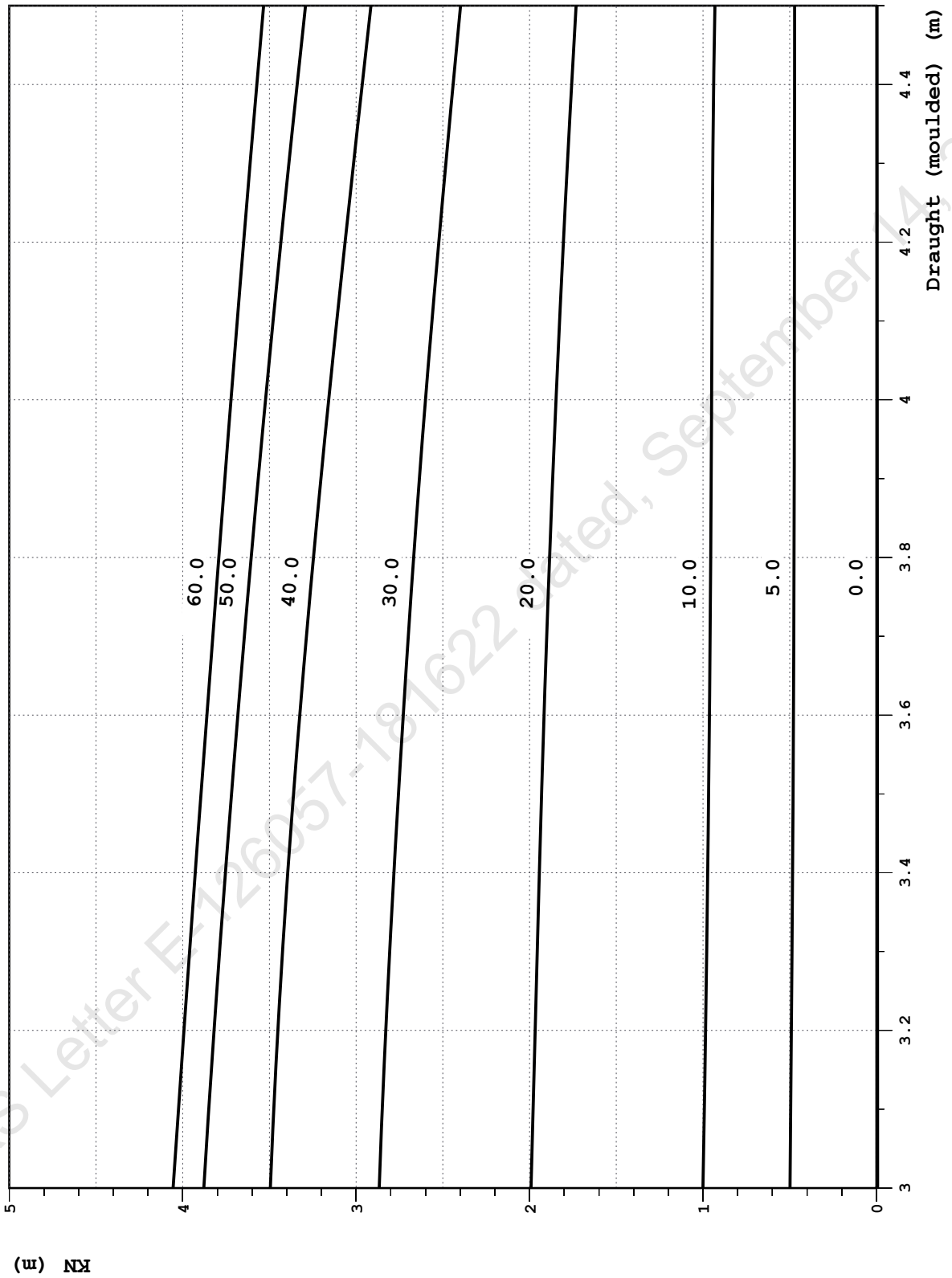

11. LOADING CONDITIONS

LOADING CONDITIONS SUMMARY TABLE

LOADING CONDITION	T m	TR m	HEEL deg	GM m	DISP t	KG m
LIGHTSHIP - Not sailing condition	3.158	-0.588	1.0	1.261	550.2	4.417
DRY DOCKING - Not sailing condition	3.326	-0.030	0.4	1.373	591.4	4.193
LC01 - DEPARTURE (100% CONSUMABLES)	3.717	-0.172	0.8	1.552	703.8	3.899
LC02 - ARRIVAL (10% CONSUMABLES)	3.292	-0.377	0.4	1.362	584.9	4.234
LC03 - LC01+CRANE OPERATION(3T load)	3.727	-0.202	0.8	1.525	706.8	3.925
LC04 - LC02+CRANE OPERATION(3T load)	3.302	-0.410	0.4	1.331	587.9	4.264

LIGHTSHIP - Not sailing condition

Floating Position - Intact condition

Draught at AP (moulded)	3.452 m
Draught at FP (moulded)	2.864 m
Mean Draught (moulded)	3.158 m
Trim (+ by Bow)	-0.588 m
Heel (+ PS)	1.0 deg
KM above moulded BL	5.770 m
KG above moulded BL	4.417 m
GM0 (solid)	1.353 m
Free Surface Correction	0.093 m
GM (liquid)	1.261 m
Density of Water	1.025 t/m3

LCB	:	15.548 m Fwd of AP
LCF	:	14.610 m Fwd of AP
MCT	:	5.464 tm/cm
TPC	:	2.749 t/cm

LOAD SUMMARY TABLE

NAME	LOAD	MASS t	LCG m	TCG m	VCG m
Oil Spill Dispersant	DISPERSANT	0.0	0.000	0.000	0.000
Diesel Oil	DO	0.0	0.000	0.000	0.000
Fire fighting Foam	FOAM	0.0	0.000	0.000	0.000
Fresh Water	FW	0.0	0.000	0.000	0.000
Grey Water	GWT	0.0	0.000	0.000	0.000
Lubricating Oil	LO	0.0	0.000	0.000	0.000
Sludge	SLU	0.0	0.000	0.000	0.000
Deadweight		0.0	0.000	0.000	0.000
Lightweight		550.2	15.595	0.015	4.417
Deadweight		0.0	0.000	0.000	0.000
Total weight		550.2	15.595	0.015	4.417

LOADING COMPONENTS

Diesel Oil (Density 0.860 t/m3)

NAME	PURP	FILL %	MASS t	VOL m3	LCG m	TCG m	VCG m	FRSM tm
R.FODAYTK.S	DO	0.0	0.0	0.0	7.543	-3.941	3.561	2.99
R.FODAYTK.P	DO	0.0	0.0	0.0	7.543	3.941	3.561	2.99
R.FOTK.2P	DO	0.0	0.0	0.0	14.195	3.792	1.209	4.23
R.FOTK.2S	DO	0.0	0.0	0.0	14.195	-3.792	1.209	4.23
R.FOTK.3P	DO	0.0	0.0	0.0	13.051	0.844	0.893	0.00
R.FOTK.3S	DO	0.0	0.0	0.0	13.051	-0.844	0.893	0.00
R.FOTK.1P	DO	0.0	0.0	0.0	22.155	2.887	1.394	0.00
R.FOTK.1S	DO	0.0	0.0	0.0	22.155	-2.887	1.394	0.00
TOTAL			0.0	0.0				14.44

Fresh Water (Density 1.0 t/m3)

NAME	PURP	FILL %	MASS t	VOL m3	LCG m	TCG m	VCG m	FRSM tm
R.FWTK.P	FW	0.0	0.0	0.0	26.041	2.086	2.297	8.80
R.FWTK.S	FW	0.0	0.0	0.0	26.041	-2.086	2.297	8.80
TOTAL			0.0	0.0				17.60

Lub Oil (Density 0.860 t/m3)

NAME	PURP	FILL %	MASS t	VOL m3	LCG m	TCG m	VCG m	FRSM tm
R.LOTK.P	LO	0.0	0.0	0.0	9.504	4.706	3.754	0.08
R.LOTK.S	LO	0.0	0.0	0.0	9.504	-4.706	3.754	0.08
TOTAL			0.0	0.0				0.16

FOAM (Density 1.0 t/m3)

NAME	PURP	FILL %	MASS t	VOL m3	LCG m	TCG m	VCG m	FRSM tm
R.FOAMTK	FOAM	0.0	0.0	0.0	22.239	0.000	1.043	1.63
TOTAL			0.0	0.0				1.63

DISPERSANT (Density 1.0 t/m3)

---

NAME	PURP	FILL %	MASS t	VOL m3	LCG m	TCG m	VCG m	FRSM tm
R.DISPERSANTTK	DISPERSANT	0.0	0.0	0.0	17.750	0.000	0.636	5.25
TOTAL			0.0	0.0				5.25

---

Refer IRS Letter E-126057-181622 dated, September 14, 2021

INTACT STABILITY CHECK PLOT

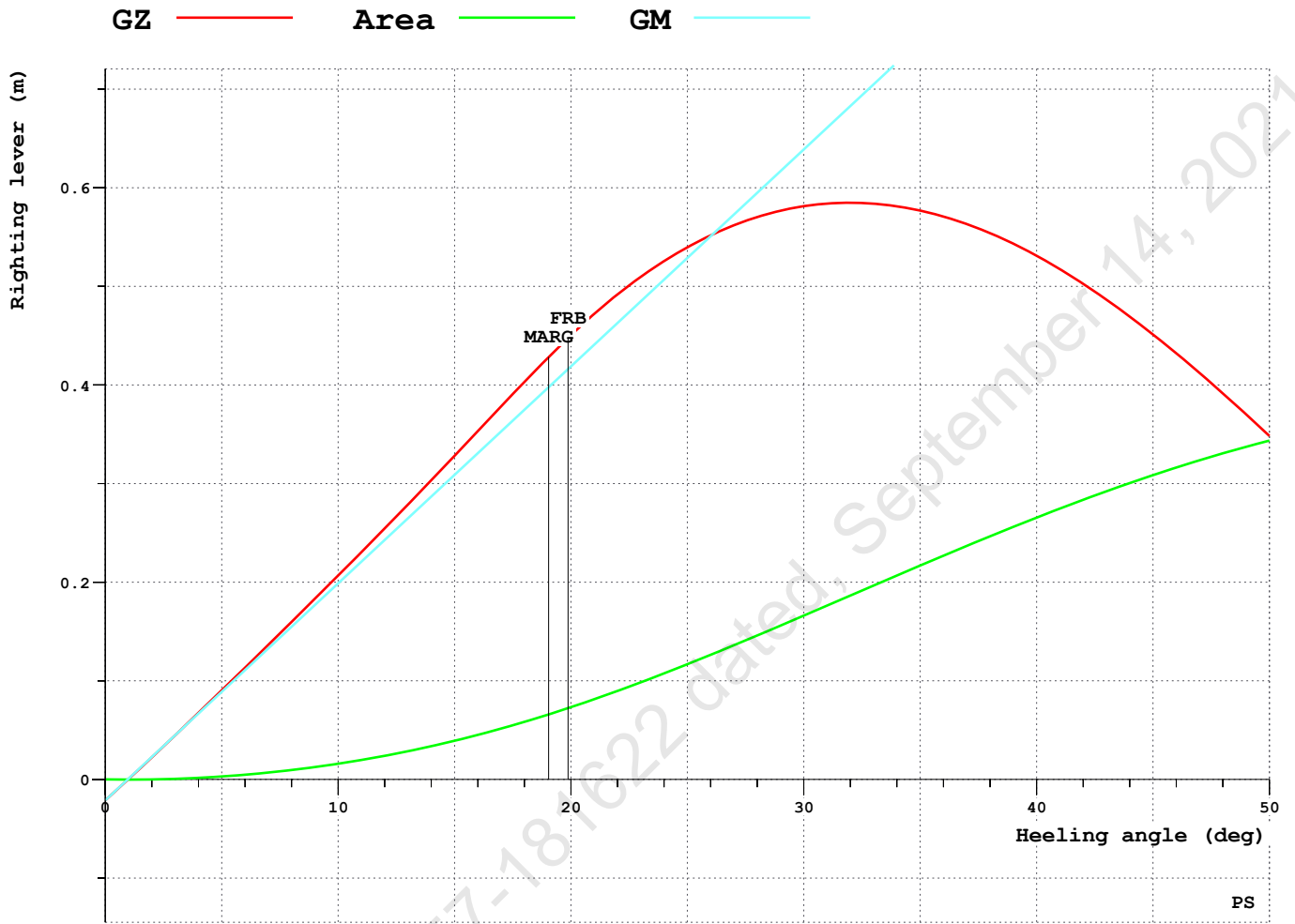

IMO WEATHER CRITERIA

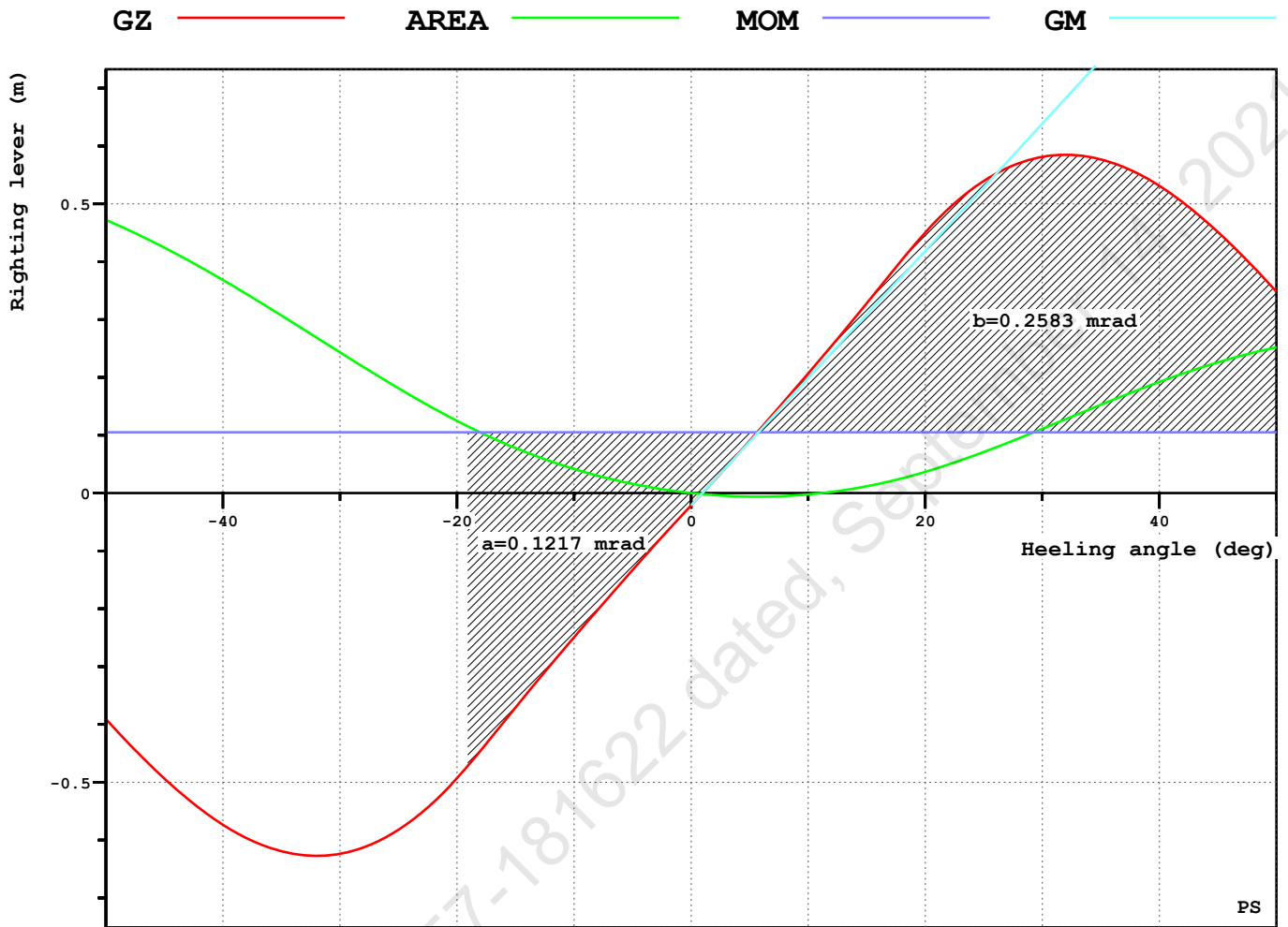

INTACT STABILITY CRITERIA

RCR	TEXT	REQ	ATTN	UNIT	STAT
AREA30	Area under GZ curve up to 30 deg.	0.055	0.166	mrاد	OK
AREA40	Area under GZ curve up to 40 deg.	0.090	0.266	mrاد	OK
AREA3040	Area under GZ curve btw. 30-40 deg.	0.030	0.099	mrاد	OK
GZ0.2	Max GZ > 0.2	0.200	0.585	m	OK
MAXGZ25	Max. GZ at an angle > 25 deg.	25.000	31.962	deg	OK
GM0.15	GM > 0.15 m	0.150	1.261	m	OK
V.IMOWEATHER	IMO weather criterion	1.000	2.122		OK
IMO.WIND_HEEL	Wind Heel <16 or <=80% of dk imm.	15.900	4.114	deg	OK
2020IS-B2.9.7.1.2	Eq. angle less than 10 deg. or dk. imm.	19.875	4.616	deg	OK
2020IS-B2.9.7.1.1	Resid. righting area > 0.08 mrad	0.080	0.147	mrاد	OK

Refer IRS Letter E-126057-181622 dated, September 14, 2021

GZ CURVE DATA

HEEL deg	T m	TR m	GZ m	AREA mrad
0.0	3.159	-0.588	-0.021	0.000
1.0	3.158	-0.588	0.000	0.000
5.0	3.142	-0.579	0.090	0.003
10.0	3.091	-0.551	0.207	0.016
15.0	3.005	-0.500	0.328	0.039
20.0	2.882	-0.427	0.451	0.073
30.0	2.548	-0.331	0.581	0.166
40.0	2.104	-0.447	0.531	0.266
50.0	1.584	-0.669	0.348	0.344

RELEVANT OPENINGS

NAME	TEXT	WT	X m	Y m	Z m	IMMA deg	IMMR m
ER_V_P	ER_INLET_P	UNPROTECTED	12.750	2.300	5.900	-	2.644
ER_V_S	ER_INLET_S	UNPROTECTED	12.750	-2.300	5.900	-	2.723
ER_O_P	ER_OUT_P	UNPROTECTED	14.000	2.300	7.900	-	4.667
ER_O_S	ER_OUT_S	UNPROTECTED	14.000	-2.300	7.900	-	4.746

DRY DOCKING - Not sailing condition

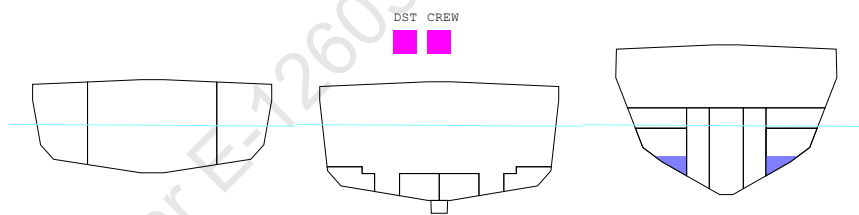
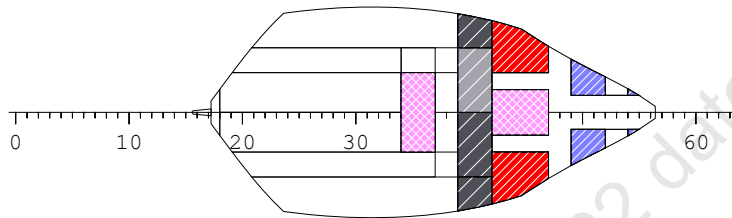
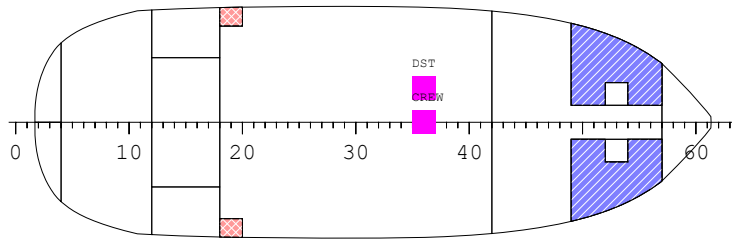
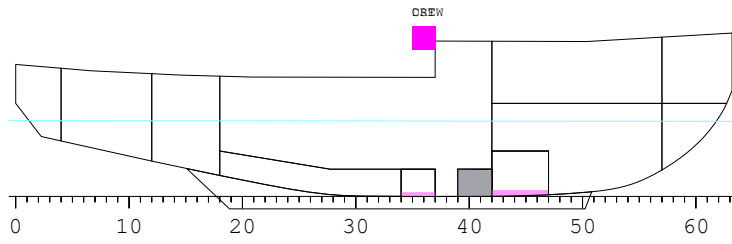

Fresh Water	Lubricating Oil	Sludge
Oil Spill Dispersant	Fire fighting Foam	Grey Water
Diesel Oil		

DRY DOCKING - Not sailing condition

Floating Position - Intact condition

Draught at AP (moulded)	3.341 m
Draught at FP (moulded)	3.310 m
Mean Draught (moulded)	3.325 m
Trim (+ by Bow)	-0.030 m
Heel (+ PS)	0.4 deg
KM above moulded BL	5.652 m
KG above moulded BL	4.193 m
GM0 (solid)	1.459 m
Free Surface Correction	0.086 m
GM (liquid)	1.373 m
Density of Water	1.025 t/m3

LCB	:	16.015 m Fwd of AP
LCF	:	14.853 m Fwd of AP
MCT	:	5.629 tm/cm
TPC	:	2.782 t/cm

LOAD SUMMARY TABLE

NAME	LOAD	MASS t	LCG m	TCG m	VCG m
Crew	CREW	1.0	18.000	0.000	7.000
Oil Spill Dispersant	DISPERSANT	0.6	17.747	0.000	0.111
Diesel Oil	DO	7.9	22.121	0.000	1.153
Deck Store	DST	0.2	18.000	1.500	7.000
Fire fighting Foam	FOAM	0.9	22.139	0.000	0.173
Fresh Water	FW	9.4	25.668	0.000	1.499
Grey Water	GWT	3.9	20.242	1.279	0.668
Lubricating Oil	LO	0.5	9.540	0.000	2.394
Sludge	SLU	16.8	20.226	-0.724	0.833
Deadweight		41.2	21.657	-0.167	1.203
Lightweight		550.2	15.595	0.015	4.417
Deadweight		41.2	21.657	-0.167	1.203
Total weight		591.4	16.017	0.002	4.193

LOADING COMPONENTS

Diesel Oil (Density 0.860 t/m3)

NAME	PURP	FILL %	MASS t	VOL m3	LCG m	TCG m	VCG m	FRSM tm
R.FODAYTK.S	DO	0.0	0.0	0.0	7.543	-3.941	3.561	2.99
R.FODAYTK.P	DO	0.0	0.0	0.0	7.543	3.941	3.561	2.99
R.FOTK.2P	DO	0.0	0.0	0.0	14.195	3.792	1.209	4.23
R.FOTK.2S	DO	0.0	0.0	0.0	14.195	-3.792	1.209	4.23
R.FOTK.3P	DO	0.0	0.0	0.0	13.051	0.844	0.893	0.00
R.FOTK.3S	DO	0.0	0.0	0.0	13.051	-0.844	0.893	0.00
R.FOTK.1P	DO	62.4	3.9	4.6	22.155	2.887	1.394	0.00
R.FOTK.1S	DO	62.4	3.9	4.6	22.155	-2.887	1.394	0.00
TOTAL			7.9	9.2				14.44

Fresh Water (Density 1.0 t/m3)

NAME	PURP	FILL %	MASS t	VOL m3	LCG m	TCG m	VCG m	FRSM tm
R.FWTK.P	FW	29.3	4.7	4.7	26.041	2.086	2.297	8.80
R.FWTK.S	FW	29.3	4.7	4.7	26.041	-2.086	2.297	8.80
TOTAL			9.4	9.4				17.60

Lub Oil (Density 0.860 t/m3)

NAME	PURP	FILL %	MASS t	VOL m3	LCG m	TCG m	VCG m	FRSM tm
R.LOTK.P	LO	10.0	0.2	0.3	9.504	4.706	3.754	0.08
R.LOTK.S	LO	10.0	0.2	0.3	9.504	-4.706	3.754	0.08
TOTAL			0.5	0.5				0.16

FOAM (Density 1.0 t/m3)

NAME	PURP	FILL %	MASS t	VOL m3	LCG m	TCG m	VCG m	FRSM tm
R.FOAMTK	FOAM	10.0	0.9	0.9	22.239	0.000	1.043	1.63
TOTAL			0.9	0.9				1.63

DISPERSANT (Density 1.0 t/m3)

NAME	PURP	FILL %	MASS t	VOL m3	LCG m	TCG m	VCG m	FRSM tm
R.DISPERSANTTK	DISPERSANT	10.0	0.6	0.6	17.750	0.000	0.636	5.25
TOTAL			0.6	0.6				5.25

STORES

NAME	PURP	MASS t	LCG m	TCG m	VCG m
STORES	MASS	0.2	18.000	1.500	7.000
TOTAL		0.2	18.000	1.500	7.000

CREW

NAME	PURP	MASS t	LCG m	TCG m	VCG m
CREW	MASS	1.0	18.000	0.000	7.000
TOTAL		1.0	18.000	0.000	7.000

INTACT STABILITY CHECK PLOT

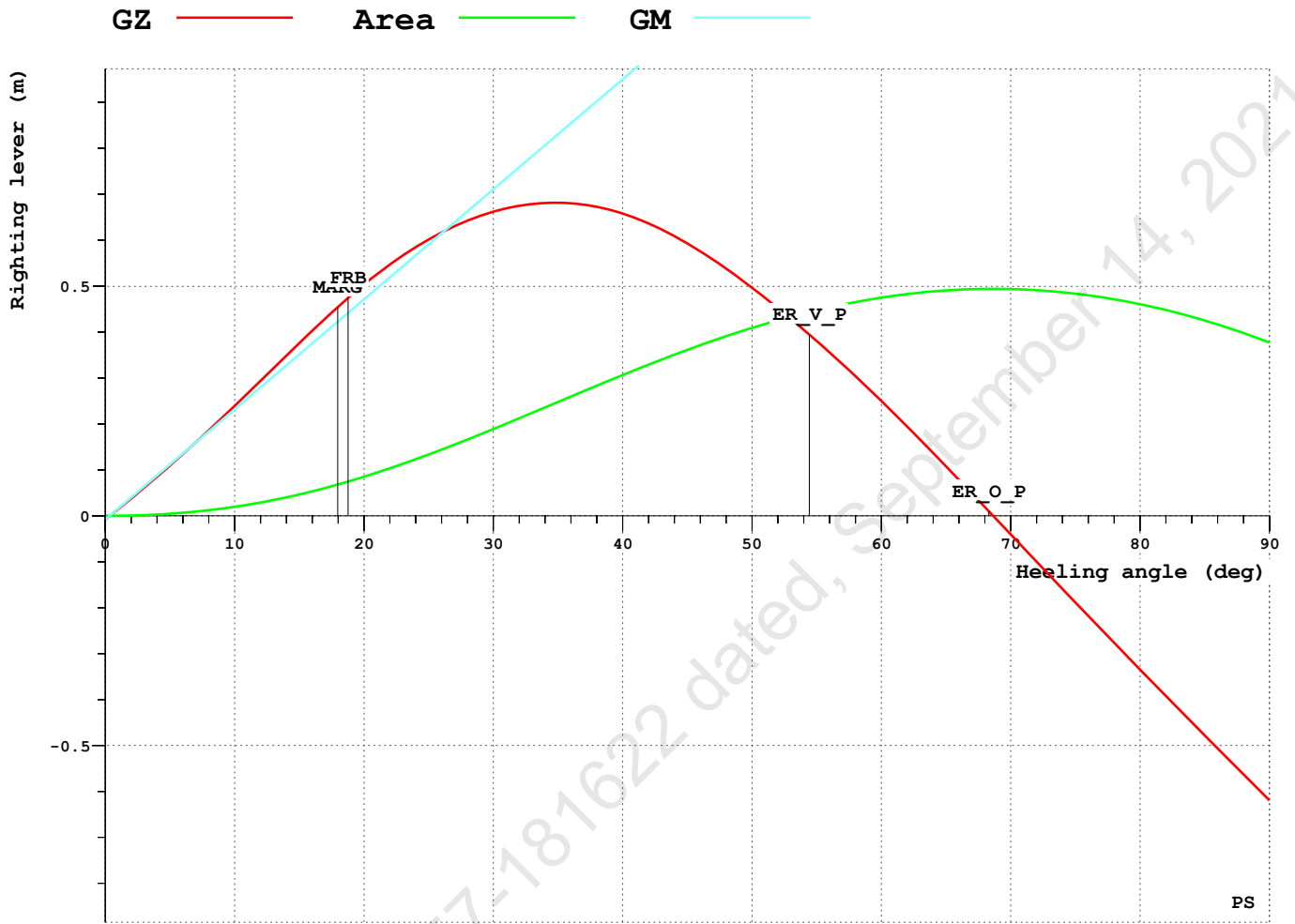

IMO WEATHER CRITERIA

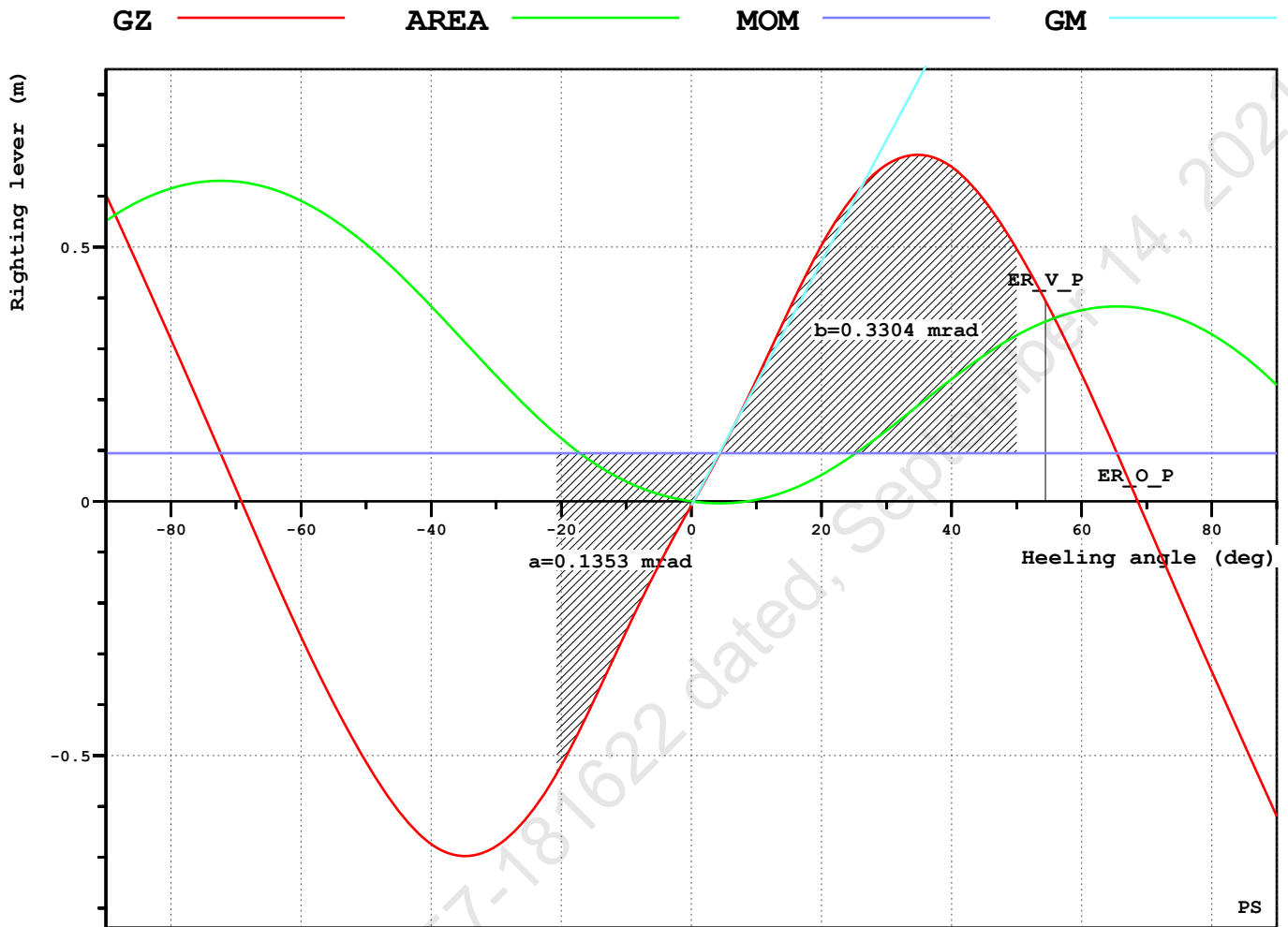

INTACT STABILITY CRITERIA

RCR	TEXT	REQ	ATTN	UNIT	STAT
AREA30	Area under GZ curve up to 30 deg.	0.055	0.189	mrاد	OK
AREA40	Area under GZ curve up to 40 deg.	0.090	0.306	mrاد	OK
AREA3040	Area under GZ curve btw. 30-40 deg.	0.030	0.118	mrاد	OK
GZ0.2	Max GZ > 0.2	0.200	0.681	m	OK
MAXGZ25	Max. GZ at an angle > 25 deg.	25.000	34.790	deg	OK
GM0.15	GM > 0.15 m	0.150	1.373	m	OK
V.IMOWEATHER	IMO weather criterion	1.000	2.443		OK
IMO.WIND_HEEL	Wind Heel <16 or <=80% of dk imm.	15.015	3.093	deg	OK

Refer IRS Letter E-126057-181622 dated, September 14, 2021

GZ CURVE DATA

HEEL deg	T m	TR m	GZ m	AREA mrad
0.0	3.326	-0.030	-0.008	0.000
0.4	3.326	-0.030	0.000	0.000
10.0	3.256	-0.001	0.239	0.019
20.0	3.040	0.108	0.504	0.085
30.0	2.711	0.177	0.662	0.189
40.0	2.278	0.048	0.658	0.306
50.0	1.775	-0.152	0.497	0.409
60.0	1.230	-0.351	0.250	0.475
70.0	0.657	-0.535	-0.041	0.494
80.0	0.083	-0.695	-0.335	0.461
90.0	-0.480	-0.900	-0.619	0.377

RELEVANT OPENINGS

NAME	TEXT	WT	X m	Y m	Z m	IMMA deg	IMMR m
ER_V_P	ER_INLET_P	UNPROTECTED	12.750	2.300	5.900	54.4	2.557
ER_V_S	ER_INLET_S	UNPROTECTED	12.750	-2.300	5.900	-	2.586
ER_O_P	ER_OUT_P	UNPROTECTED	14.000	2.300	7.900	68.3	4.558
ER_O_S	ER_OUT_S	UNPROTECTED	14.000	-2.300	7.900	-	4.587

LC01 - DEPARTURE (100% CONSUMABLES)

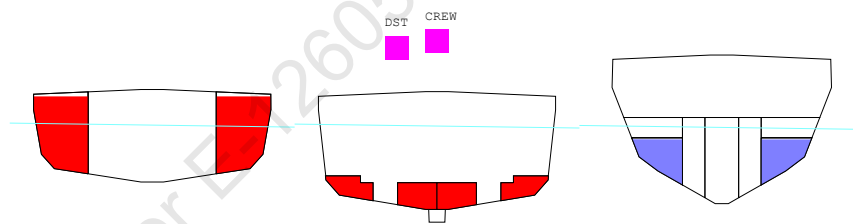
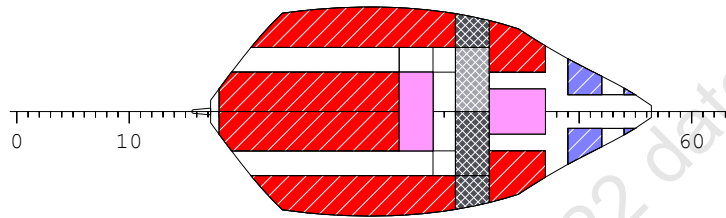
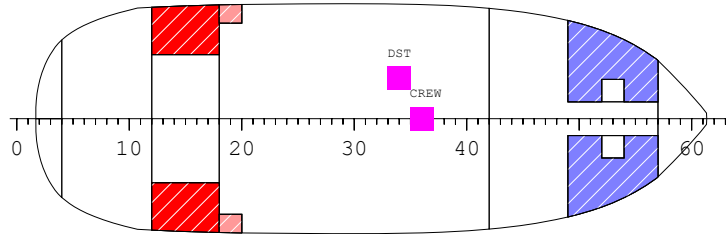
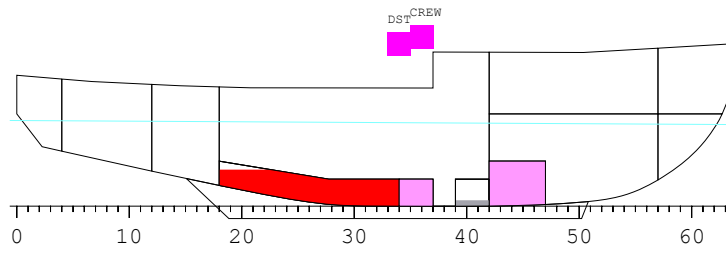

Fresh Water	Oil Spill Dispersant	Sludge
Diesel Oil	Fire fighting Foam	Grey Water
	Lubricating Oil	

LC01 - DEPARTURE (100% CONSUMABLES)

Floating Position - Intact condition

Draught at AP (moulded)	3.803 m
Draught at FP (moulded)	3.631 m
Mean Draught (moulded)	3.717 m
Trim (+ by Bow)	-0.172 m
Heel (+ PS)	0.8 deg
KM above moulded BL	5.524 m
KG above moulded BL	3.899 m
GM0 (solid)	1.625 m
Free Surface Correction	0.073 m
GM (liquid)	1.552 m
Density of Water	1.025 t/m3

LCB	: 15.700 m Fwd of AP
LCF	: 14.724 m Fwd of AP
MCT	: 6.146 tm/cm
TPC	: 2.889 t/cm

LOAD SUMMARY TABLE

NAME	LOAD	MASS t	LCG m	TCG m	VCG m
Crew	CREW	1.0	18.000	0.000	7.500
Oil Spill Dispersant	DISPERSANT	5.8	17.750	0.000	0.636
Diesel Oil	DO	98.4	12.536	0.000	1.965
Deck Store	DST	2.0	17.000	1.800	7.200
Fire fighting Foam	FOAM	9.4	22.239	0.000	1.043
Fresh Water	FW	30.5	26.028	0.000	2.251
Grey Water	GWT	0.4	20.224	0.598	0.155
Lubricating Oil	LO	4.4	9.505	0.000	3.686
Sludge	SLU	1.8	20.166	-0.338	0.372
Deadweight		153.6	16.118	0.021	2.045
Lightweight		550.2	15.595	0.015	4.417
Deadweight		153.6	16.118	0.021	2.045
Total weight		703.8	15.709	0.016	3.899

LOADING COMPONENTS

Diesel Oil (Density 0.860 t/m3)

NAME	PURP	FILL %	MASS t	VOL m3	LCG m	TCG m	VCG m	FRSM tm
R.FODAYTK.S	DO	95.0	18.2	21.1	7.543	-3.941	3.561	2.99
R.FODAYTK.P	DO	95.0	18.2	21.1	7.543	3.941	3.561	2.99
R.FOTK.2P	DO	95.0	12.9	15.0	14.195	3.792	1.209	4.23
R.FOTK.2S	DO	95.0	12.9	15.0	14.195	-3.792	1.209	4.23
R.FOTK.3P	DO	95.0	12.2	14.1	13.051	0.844	0.893	0.00
R.FOTK.3S	DO	95.0	12.2	14.1	13.051	-0.844	0.893	0.00
R.FOTK.1P	DO	95.0	6.0	7.0	22.155	2.887	1.394	0.00
R.FOTK.1S	DO	95.0	6.0	7.0	22.155	-2.887	1.394	0.00
TOTAL			98.4	114.5				14.44

Fresh Water (Density 1.0 t/m3)

NAME	PURP	FILL %	MASS t	VOL m3	LCG m	TCG m	VCG m	FRSM tm
R.FWTK.P	FW	95.0	15.2	15.2	26.041	2.086	2.297	8.80
R.FWTK.S	FW	95.0	15.2	15.2	26.041	-2.086	2.297	8.80
TOTAL			30.5	30.5				17.60

Lub Oil (Density 0.860 t/m3)

NAME	PURP	FILL %	MASS t	VOL m3	LCG m	TCG m	VCG m	FRSM tm
R.LOTK.P	LO	95.0	2.2	2.4	9.504	4.706	3.754	0.08
R.LOTK.S	LO	95.0	2.2	2.4	9.504	-4.706	3.754	0.08
TOTAL			4.4	4.8				0.16

FOAM (Density 1.0 t/m3)

NAME	PURP	FILL %	MASS t	VOL m3	LCG m	TCG m	VCG m	FRSM tm
R.FOAMTK	FOAM	100.0	9.4	9.4	22.239	0.000	1.043	1.63
TOTAL			9.4	9.4				1.63

DISPERSANT (Density 1.0 t/m3)

NAME	PURP	FILL %	MASS t	VOL m3	LCG m	TCG m	VCG m	FRSM tm
R.DISPERSANTTK	DISPERSANT	100.0	5.8	5.8	17.750	0.000	0.636	5.25
TOTAL			5.8	5.8				5.25

STORES

NAME	PURP	MASS t	LCG m	TCG m	VCG m
STORES	MASS	2.0	17.000	1.800	7.200
TOTAL		2.0	17.000	1.800	7.200

CREW

NAME	PURP	MASS t	LCG m	TCG m	VCG m
CREW	MASS	1.0	18.000	0.000	7.500
TOTAL		1.0	18.000	0.000	7.500

INTACT STABILITY CHECK PLOT

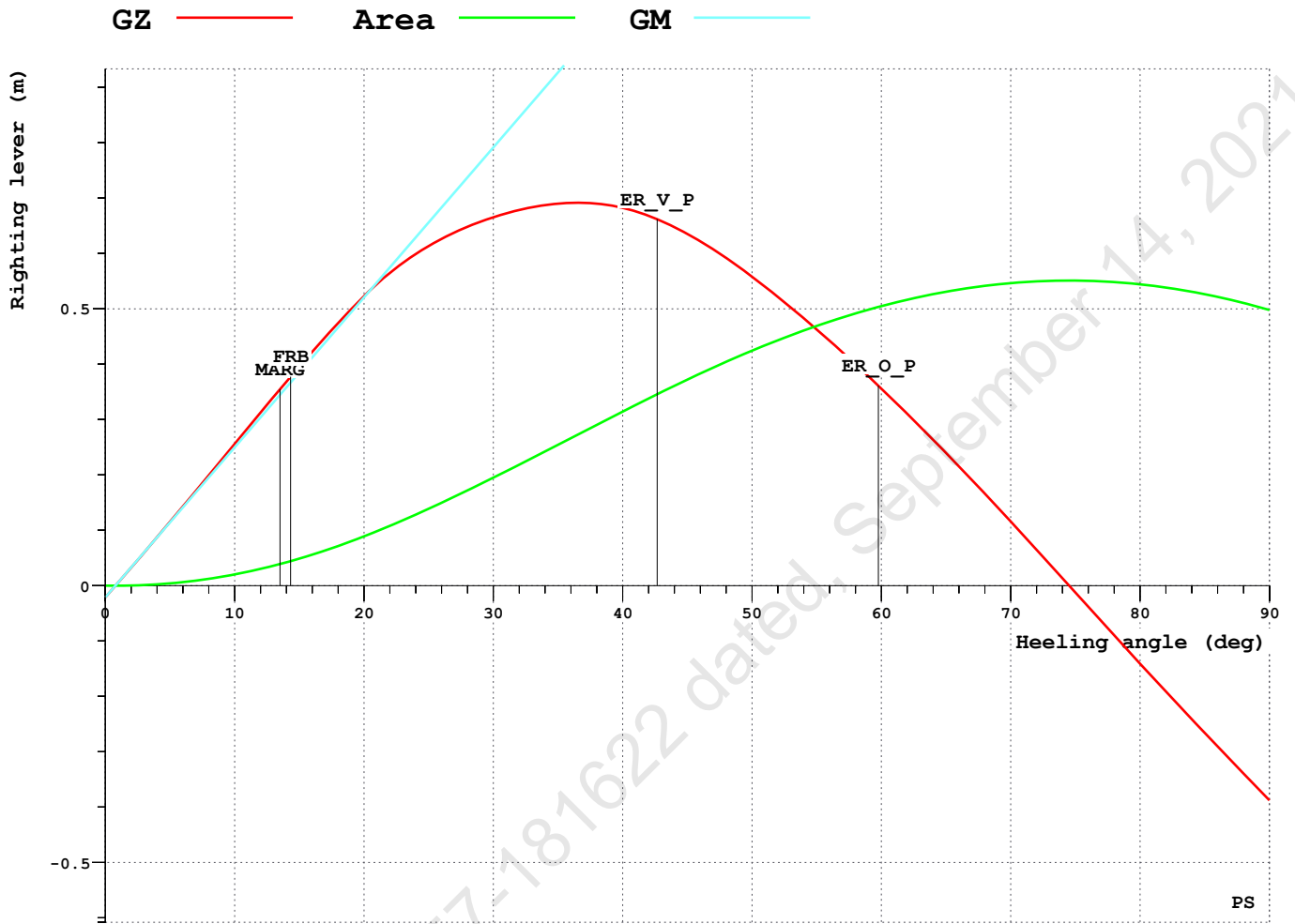

IMO WEATHER CRITERIA

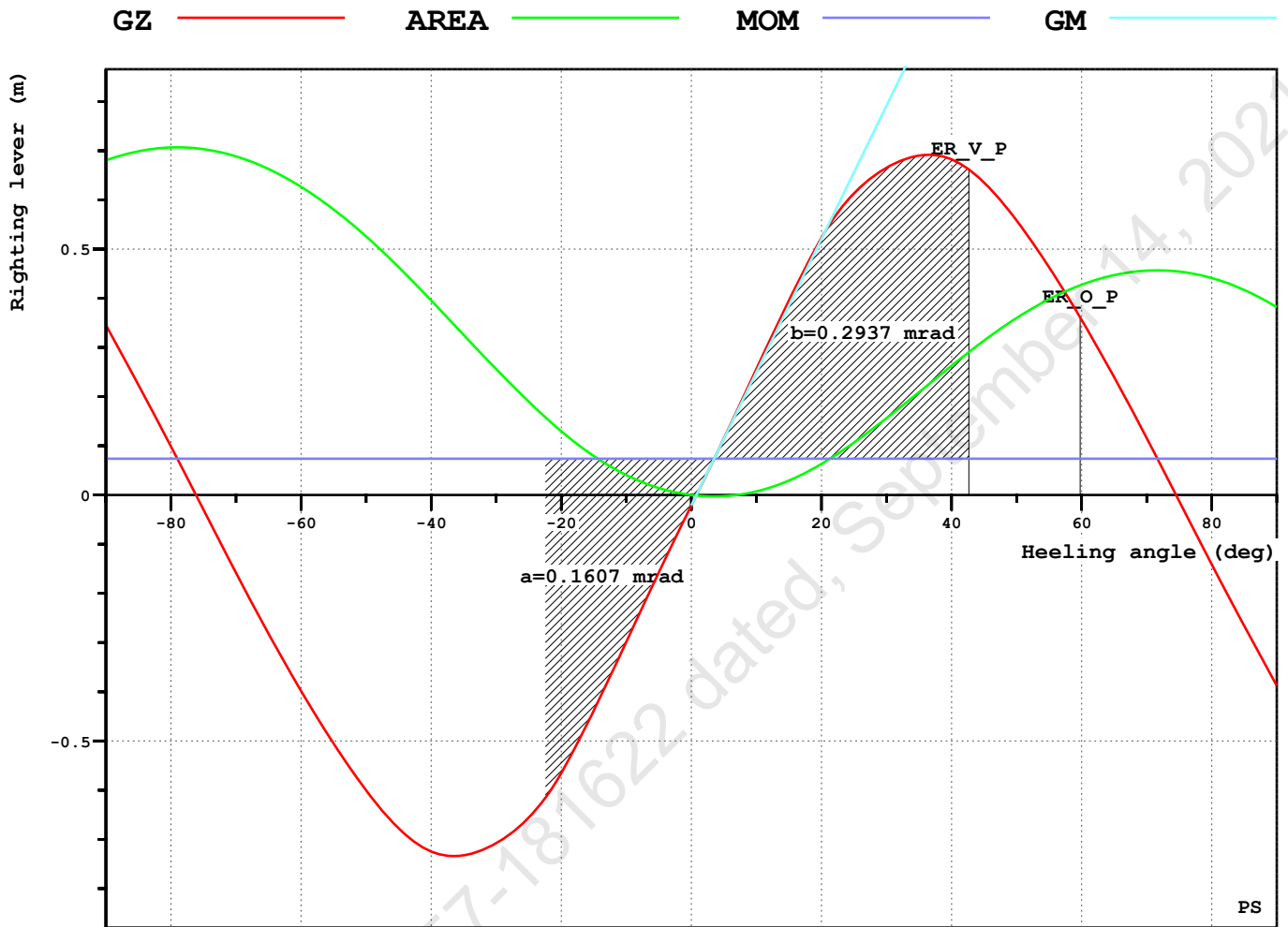

EXTERNAL FI-FI

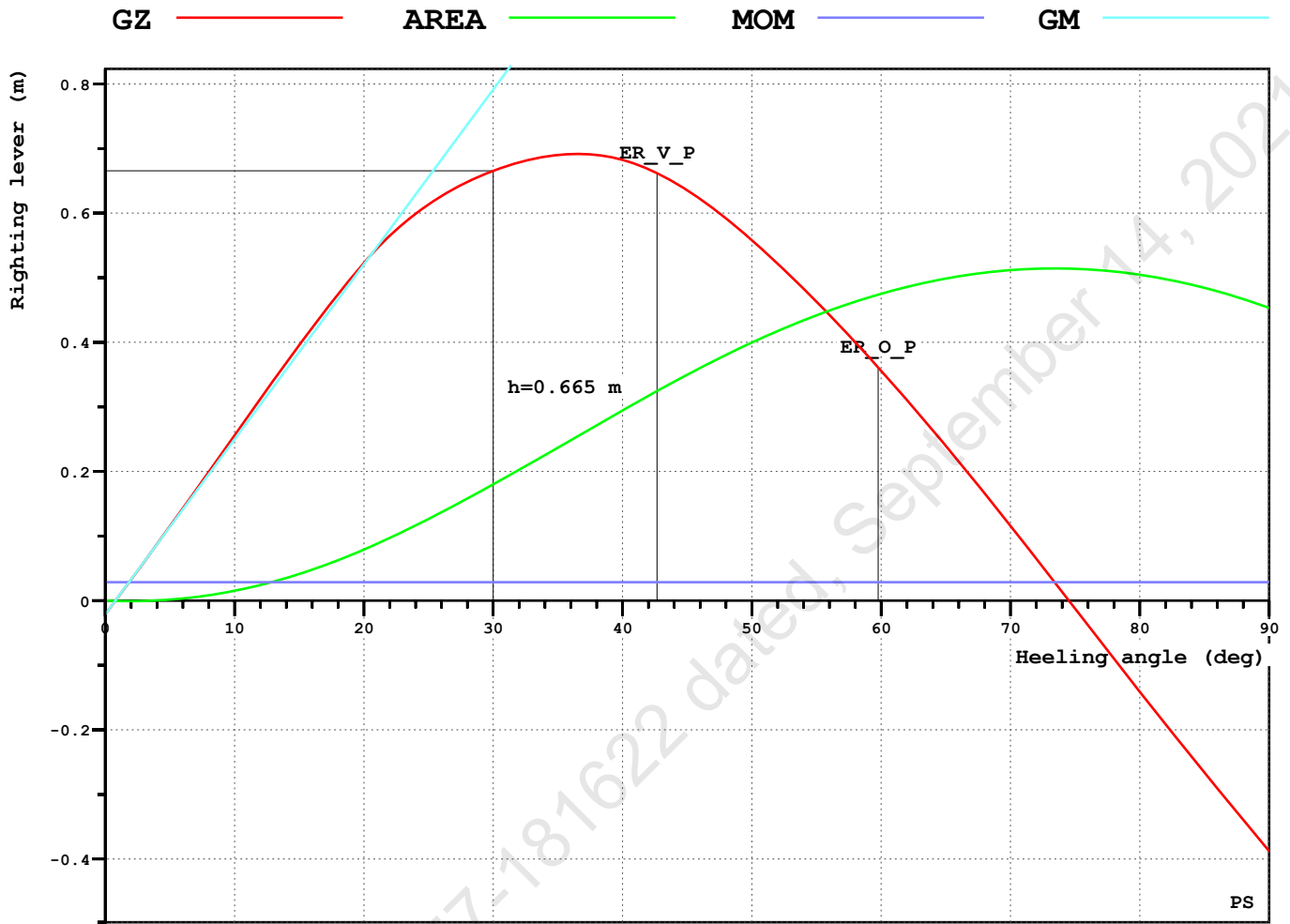

IS CODE TOWING - Self Tripping

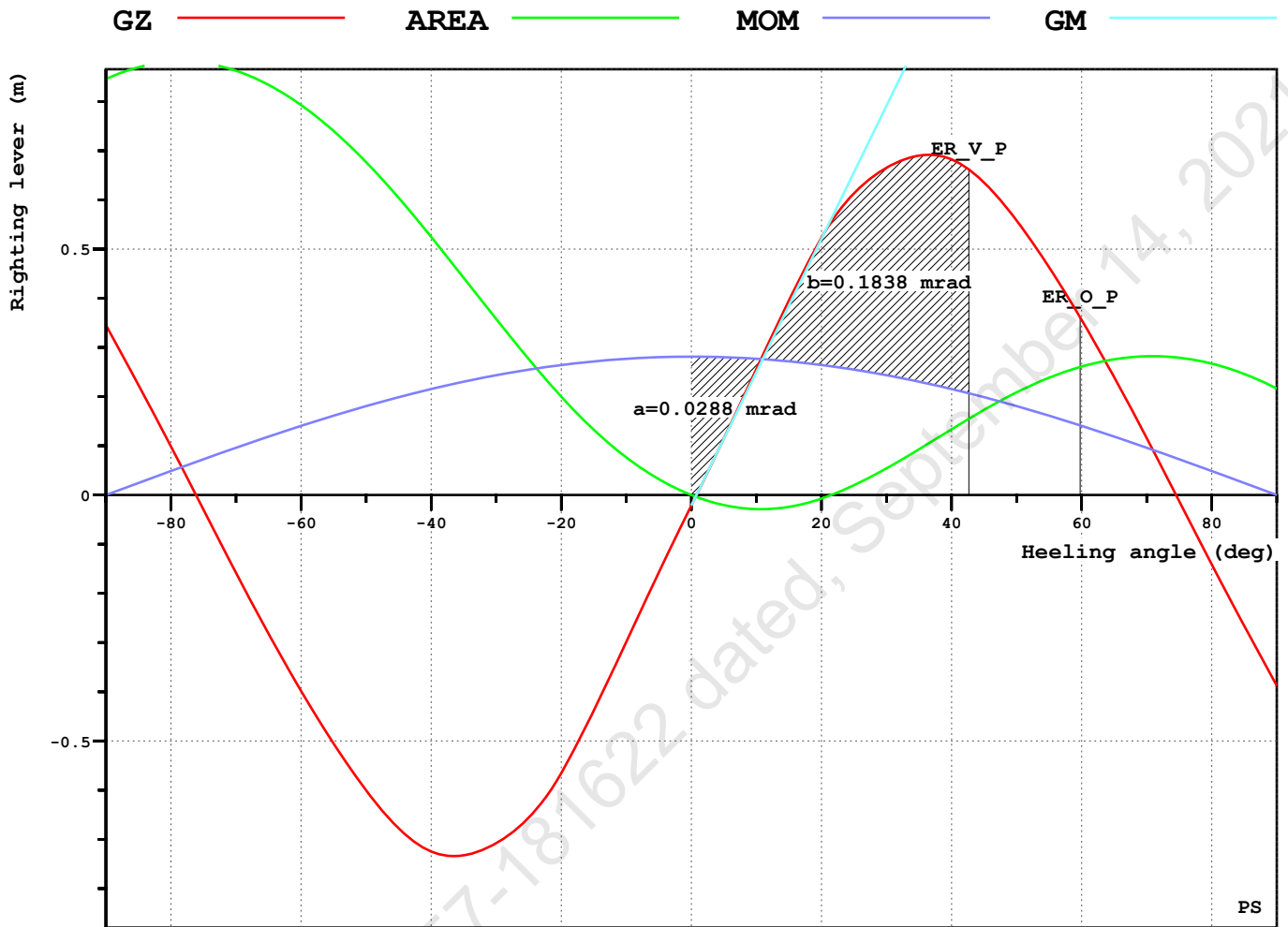

IS CODE TOWING - Tow Tripping

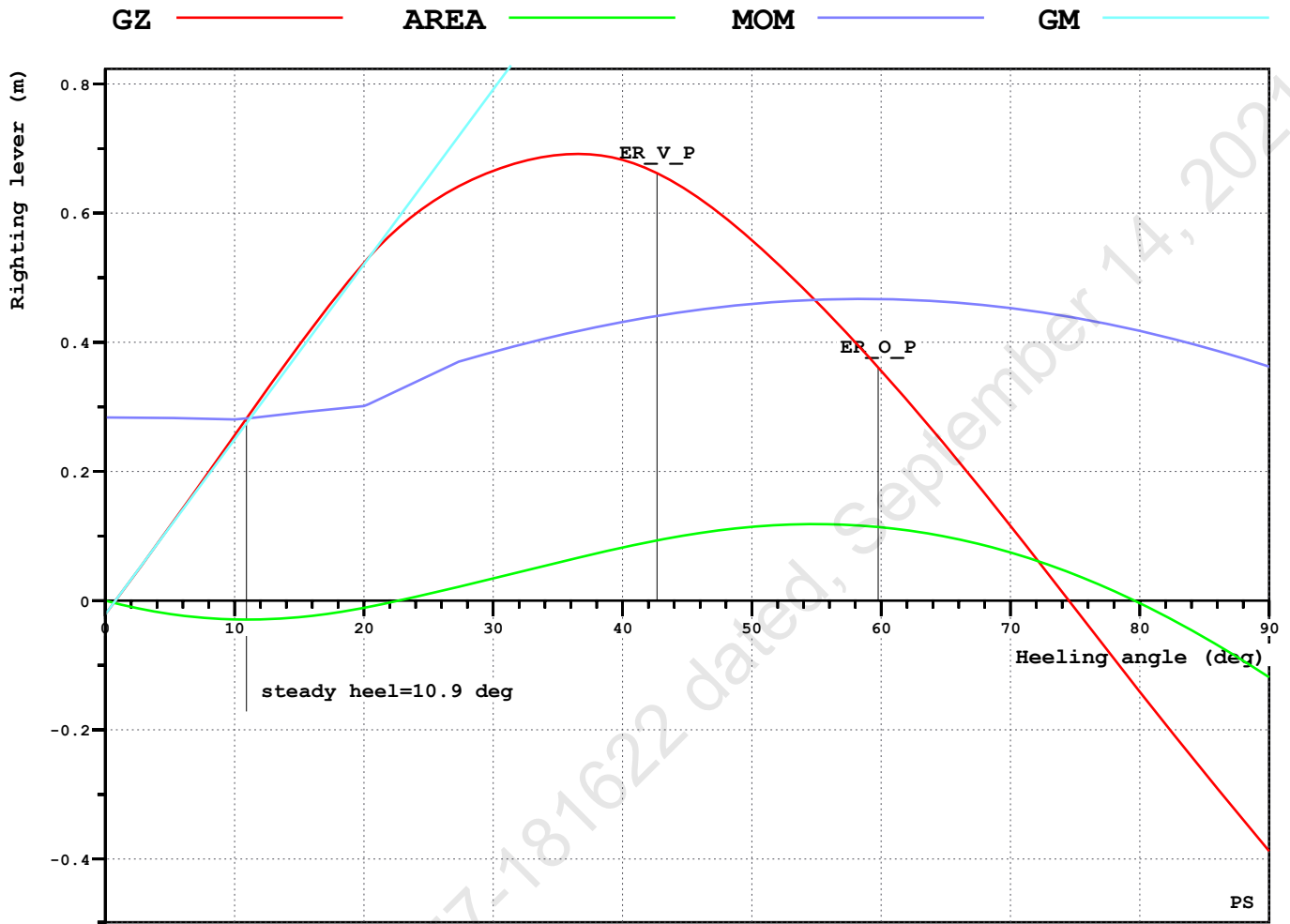

INTACT STABILITY CRITERIA

RCR	TEXT	REQ	ATTV	UNIT	STAT
AREA30	Area under GZ curve up to 30 deg.	0.055	0.195	mrاد	OK
AREA40	Area under GZ curve up to 40 deg.	0.090	0.315	mrاد	OK
AREA3040	Area under GZ curve btw. 30-40 deg.	0.030	0.120	mrاد	OK
GZ0.2	Max GZ > 0.2	0.200	0.692	m	OK
MAXGZ25	Max. GZ at an angle > 25 deg.	25.000	36.514	deg	OK
GM0.15	GM > 0.15 m	0.150	1.552	m	OK
V.IMOWEATHER	IMO weather criterion	1.000	1.827		OK
IMO.WIND_HEEL	Wind Heel <16 or <=80% of dk imm.	11.459	2.617	deg	OK
FIFI_GZ	Min. GZ for Fire fighter Ships	0.057	0.665	m	OK
2020IS-B2.8.4.2	AreaA>=AreaB	1.000	6.389		OK
2020IS-B2.8.4.3	Max. heel, tow-tr.	42.666	10.918	deg	OK

Refer IRS Letter E-126057-181622 dated, September 14, 2021

GZ CURVE DATA

HEEL deg	T m	TR m	GZ m	AREA mrad
0.0	3.718	-0.172	-0.021	0.000
0.8	3.717	-0.172	0.000	0.000
10.0	3.643	-0.154	0.256	0.020
20.0	3.439	-0.136	0.523	0.089
30.0	3.167	-0.304	0.665	0.195
40.0	2.815	-0.641	0.682	0.314
50.0	2.391	-0.999	0.558	0.424
60.0	1.905	-1.333	0.356	0.505
70.0	1.373	-1.617	0.116	0.546
80.0	0.809	-1.839	-0.141	0.544
90.0	0.236	-1.985	-0.388	0.498

RELEVANT OPENINGS

NAME	TEXT	WT	X m	Y m	Z m	IMMA deg	IMMR m
ER_V_P	ER_INLET_P	UNPROTECTED	12.750	2.300	5.900	42.7	2.134
ER_V_S	ER_INLET_S	UNPROTECTED	12.750	-2.300	5.900	-	2.198
ER_O_P	ER_OUT_P	UNPROTECTED	14.000	2.300	7.900	59.8	4.140
ER_O_S	ER_OUT_S	UNPROTECTED	14.000	-2.300	7.900	-	4.204

LC02 - ARRIVAL (10% CONSUMABLES)

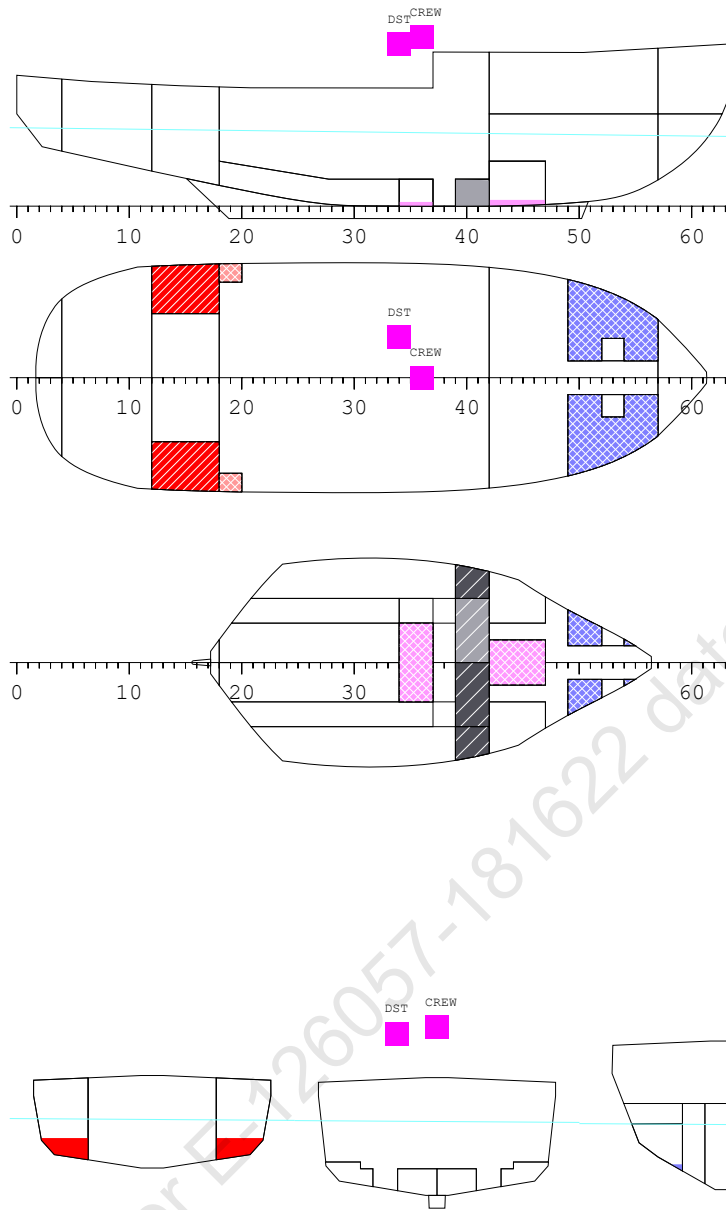

Fresh Water	Lubricating Oil	Sludge
Oil Spill Dispersant	Fire fighting Foam	Grey Water
Diesel Oil		

LC02 - ARRIVAL (10% CONSUMABLES)

Floating Position - Intact condition

Draught at AP (moulded)	3.480 m
Draught at FP (moulded)	3.103 m
Mean Draught (moulded)	3.292 m
Trim (+ by Bow)	-0.377 m
Heel (+ PS)	0.4 deg
KM above moulded BL	5.684 m
KG above moulded BL	4.234 m
GM0 (solid)	1.450 m
Free Surface Correction	0.087 m
GM (liquid)	1.362 m
Density of Water	1.025 t/m3

LCB	:	15.695 m Fwd of AP
LCF	:	14.692 m Fwd of AP
MCT	:	5.613 tm/cm
TPC	:	2.78 t/cm

LOAD SUMMARY TABLE

NAME	LOAD	MASS t	LCG m	TCG m	VCG m
Crew	CREW	1.0	18.000	0.000	7.500
Oil Spill Dispersant	DISPERSANT	0.6	17.747	0.000	0.111
Diesel Oil	DO	7.6	7.730	0.000	2.142
Deck Store	DST	0.2	17.000	1.800	7.200
Fire fighting Foam	FOAM	0.9	22.139	0.000	0.173
Fresh Water	FW	3.2	25.334	0.000	1.081
Grey Water	GWT	3.9	20.242	1.279	0.668
Lubricating Oil	LO	0.5	9.540	0.000	2.394
Sludge	SLU	16.8	20.226	-0.724	0.833
Deadweight		34.7	17.737	-0.196	1.345
Lightweight		550.2	15.595	0.015	4.417
Deadweight		34.7	17.737	-0.196	1.345
Total weight		584.9	15.722	0.002	4.234

LOADING COMPONENTS

Diesel Oil (Density 0.860 t/m3)

NAME	PURP	FILL %	MASS t	VOL m3	LCG m	TCG m	VCG m	FRSM tm
R.FODAYTK.S	DO	20.0	3.8	4.4	7.543	-3.941	3.561	2.99
R.FODAYTK.P	DO	20.0	3.8	4.4	7.543	3.941	3.561	2.99
R.FOTK.2P	DO	0.0	0.0	0.0	14.195	3.792	1.209	4.23
R.FOTK.2S	DO	0.0	0.0	0.0	14.195	-3.792	1.209	4.23
R.FOTK.3P	DO	0.0	0.0	0.0	13.051	0.844	0.893	0.00
R.FOTK.3S	DO	0.0	0.0	0.0	13.051	-0.844	0.893	0.00
R.FOTK.1P	DO	0.0	0.0	0.0	22.155	2.887	1.394	0.00
R.FOTK.1S	DO	0.0	0.0	0.0	22.155	-2.887	1.394	0.00
TOTAL			7.6	8.9				14.44

Fresh Water (Density 1.0 t/m3)

NAME	PURP	FILL %	MASS t	VOL m3	LCG m	TCG m	VCG m	FRSM tm
R.FWTK.P	FW	10.0	1.6	1.6	26.041	2.086	2.297	8.80
R.FWTK.S	FW	10.0	1.6	1.6	26.041	-2.086	2.297	8.80
TOTAL			3.2	3.2				17.60

Lub Oil (Density 0.860 t/m3)

NAME	PURP	FILL %	MASS t	VOL m3	LCG m	TCG m	VCG m	FRSM tm
R.LOTK.P	LO	10.0	0.2	0.3	9.504	4.706	3.754	0.08
R.LOTK.S	LO	10.0	0.2	0.3	9.504	-4.706	3.754	0.08
TOTAL			0.5	0.5				0.16

FOAM (Density 1.0 t/m3)

NAME	PURP	FILL %	MASS t	VOL m3	LCG m	TCG m	VCG m	FRSM tm
R.FOAMTK	FOAM	10.0	0.9	0.9	22.239	0.000	1.043	1.63
TOTAL			0.9	0.9				1.63

DISPERSANT (Density 1.0 t/m3)

NAME	PURP	FILL %	MASS t	VOL m3	LCG m	TCG m	VCG m	FRSM tm
R.DISPERSANTTK	DISPERSANT	10.0	0.6	0.6	17.750	0.000	0.636	5.25
TOTAL			0.6	0.6				5.25

STORES

NAME	PURP	MASS t	LCG m	TCG m	VCG m
STORES	MASS	0.2	17.000	1.800	7.200
TOTAL		0.2	17.000	1.800	7.200

CREW

NAME	PURP	MASS t	LCG m	TCG m	VCG m
CREW	MASS	1.0	18.000	0.000	7.500
TOTAL		1.0	18.000	0.000	7.500

INTACT STABILITY CHECK PLOT

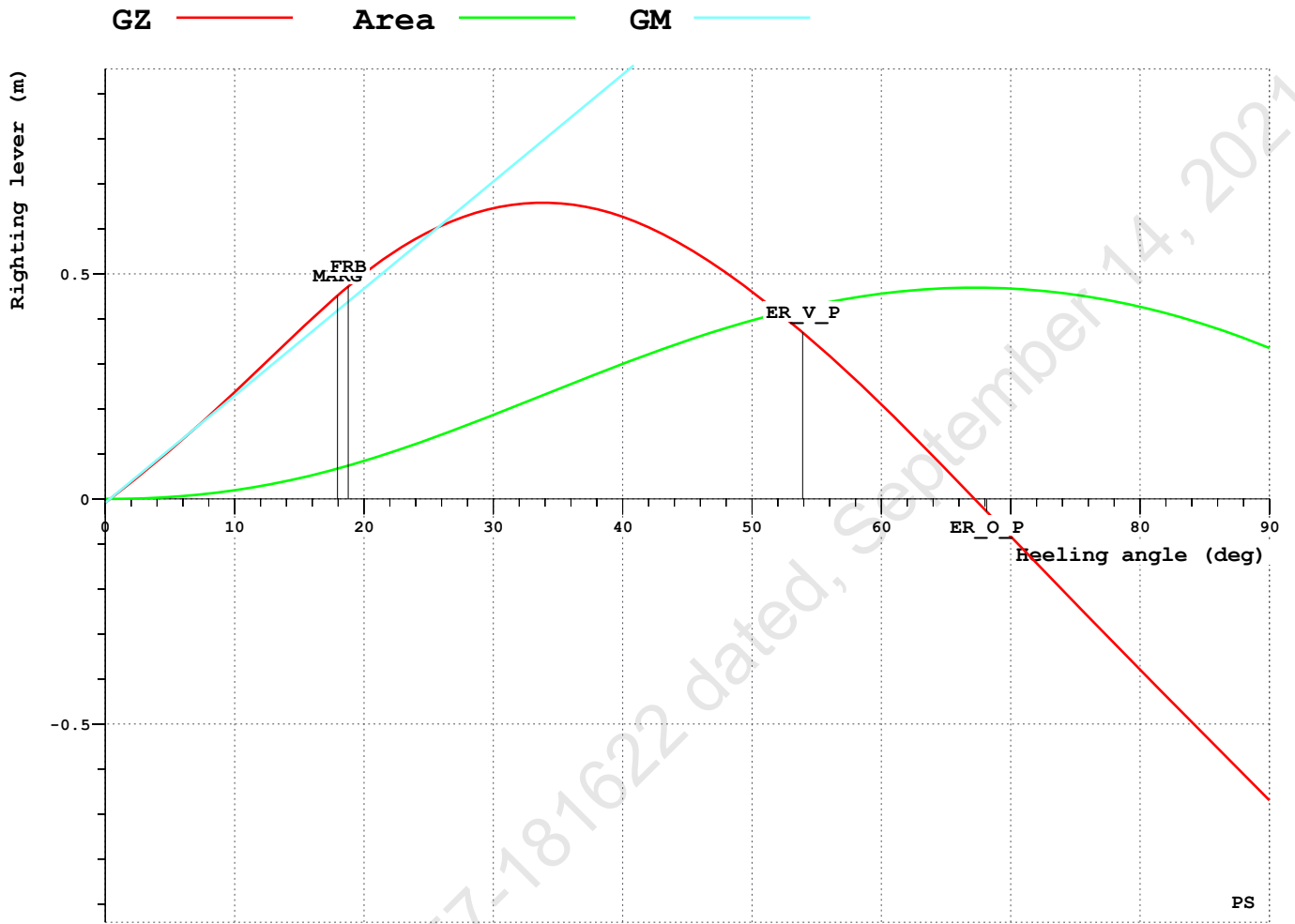

IMO WEATHER CRITERIA

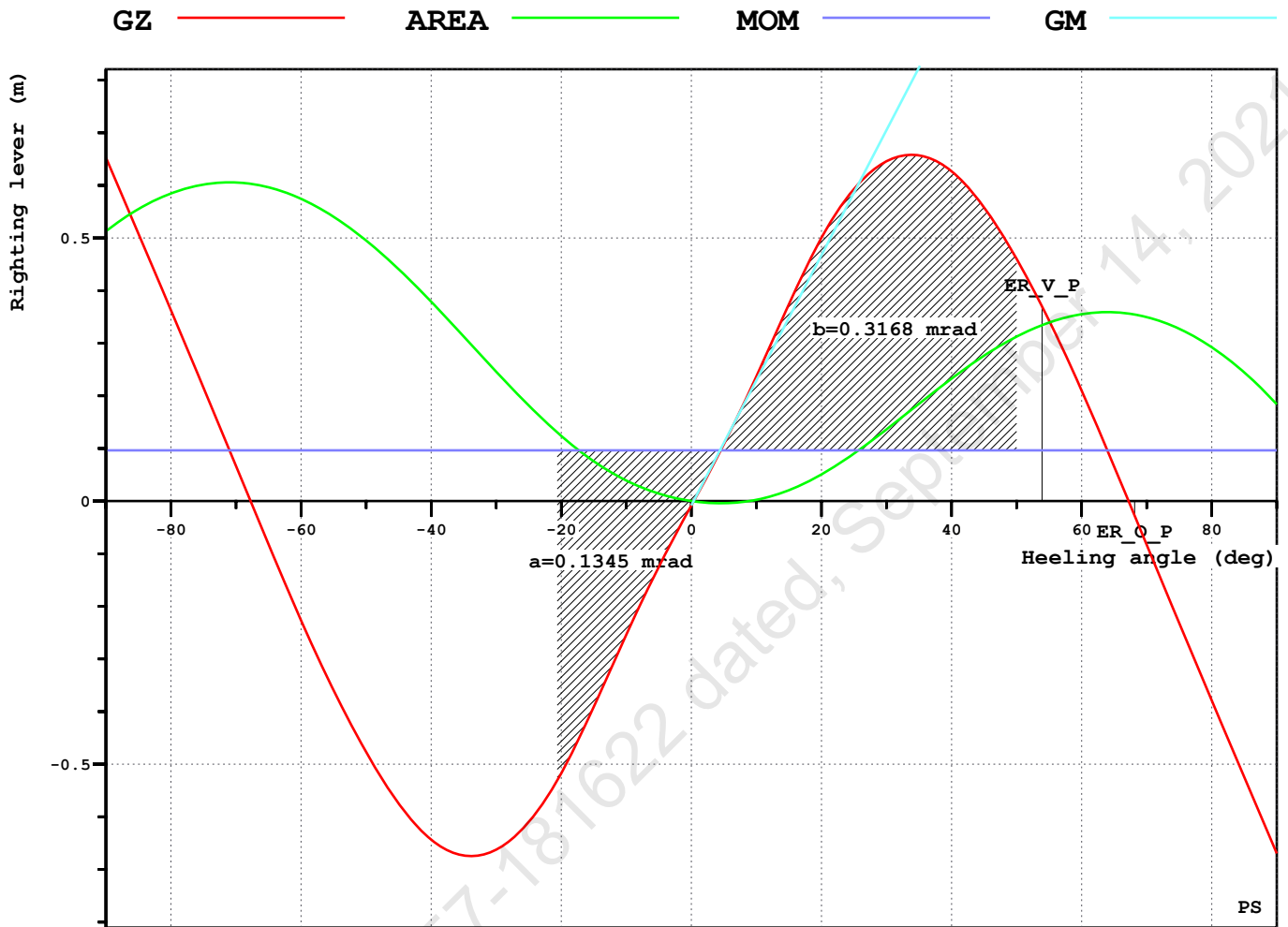

EXTERNAL FI-FI

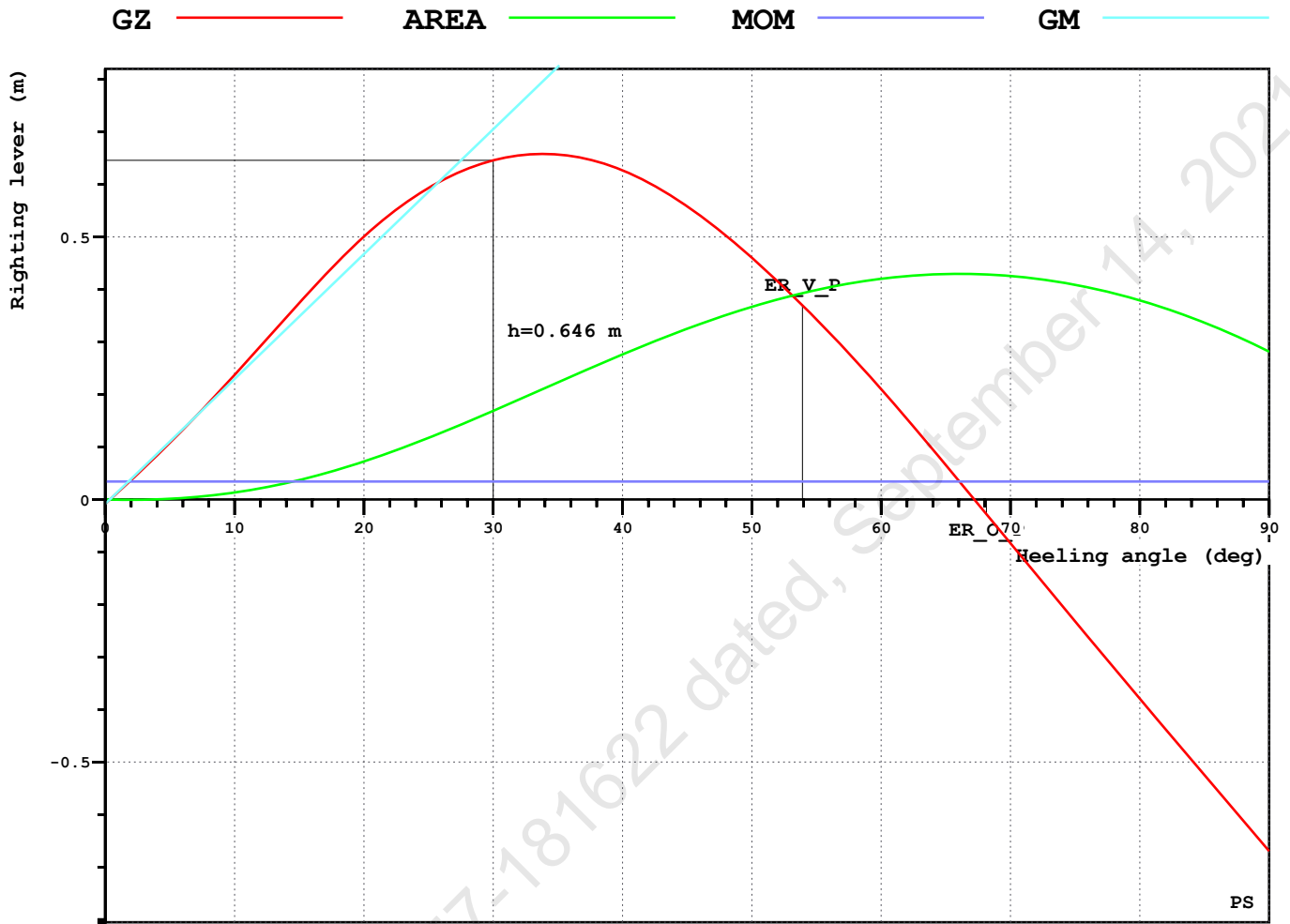

IS CODE TOWING - Self Tripping

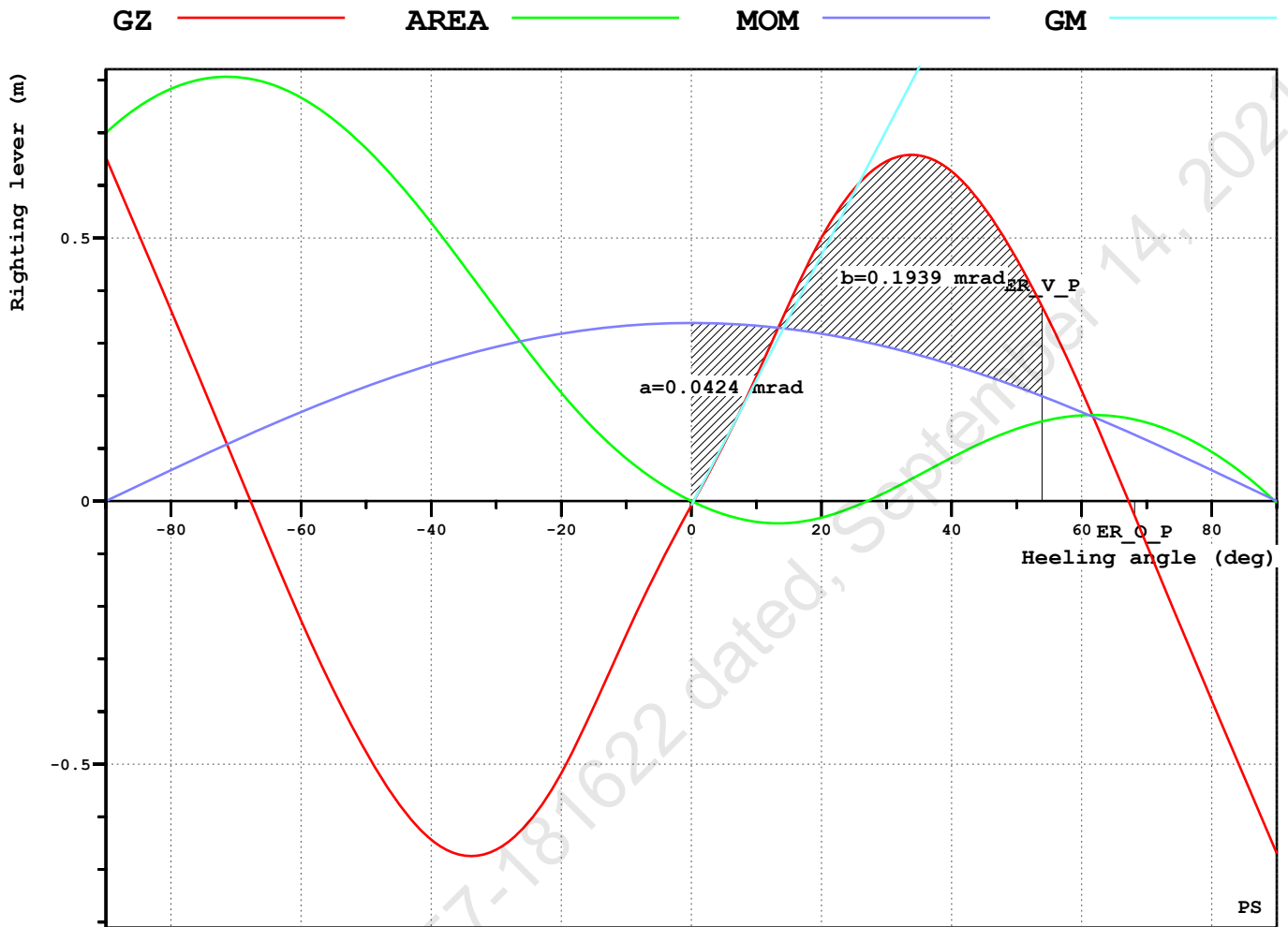

IS CODE TOWING - Tow Tripping

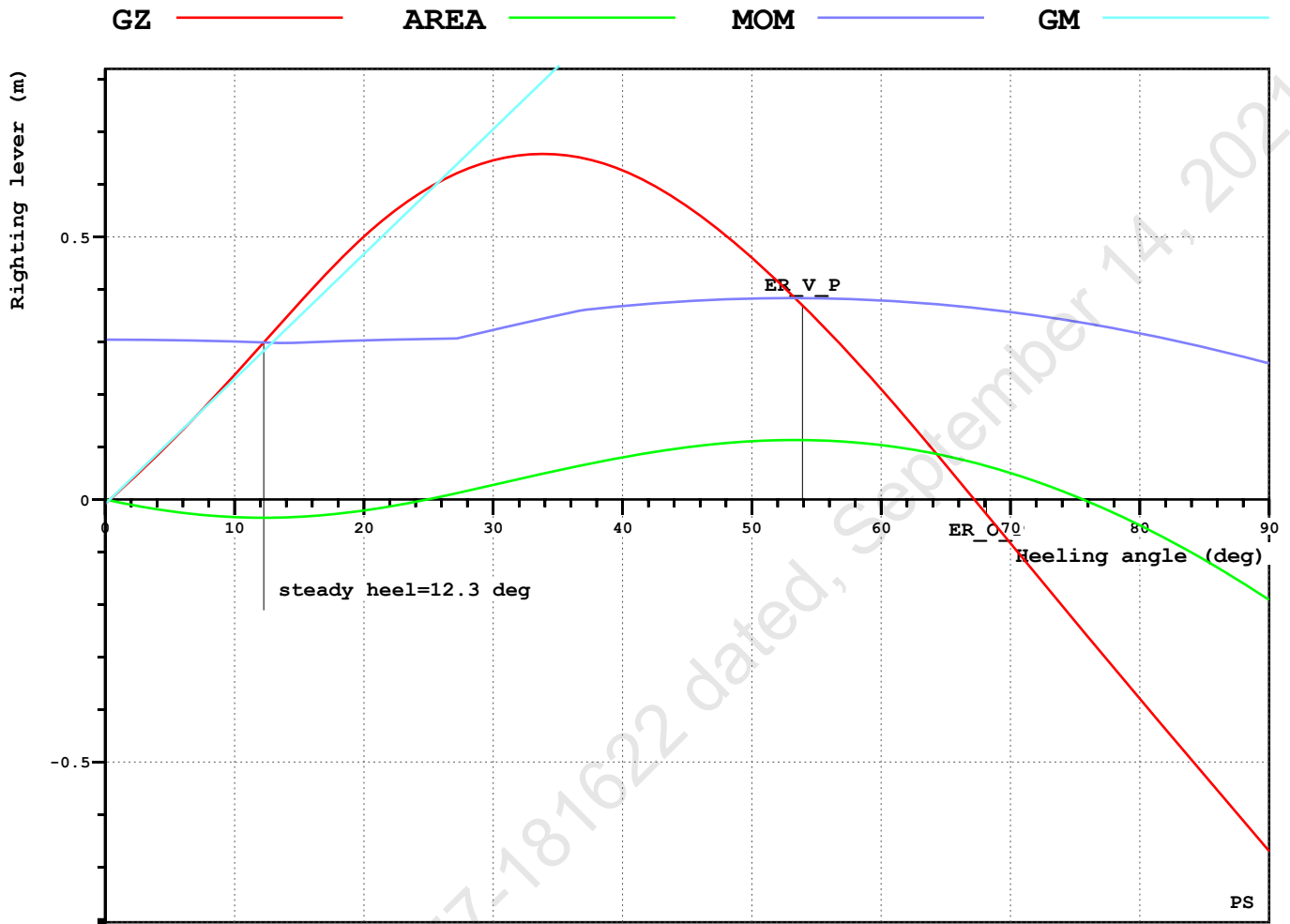

INTACT STABILITY CRITERIA

RCR	TEXT	REQ	ATTV	UNIT	STAT
AREA30	Area under GZ curve up to 30 deg.	0.055	0.187	mrاد	OK
AREA40	Area under GZ curve up to 40 deg.	0.090	0.300	mrاد	OK
AREA3040	Area under GZ curve btw. 30-40 deg.	0.030	0.113	mrاد	OK
GZ0.2	Max GZ > 0.2	0.200	0.658	m	OK
MAXGZ25	Max. GZ at an angle > 25 deg.	25.000	33.837	deg	OK
GM0.15	GM > 0.15 m	0.150	1.362	m	OK
V.IMOWEATHER	IMO weather criterion	1.000	2.354		OK
IMO.WIND_HEEL	Wind Heel <16 or <=80% of dk imm.	15.021	3.177	deg	OK
FIFI_GZ	Min. GZ for Fire fighter Ships	0.068	0.646	m	OK
2020IS-B2.8.4.2	AreaA>=AreaB	1.000	4.576		OK
2020IS-B2.8.4.3	Max. heel, tow-tr.	53.910	12.253	deg	OK

Refer IRS Letter E-126057-181622 dated, September 14, 2021

GZ CURVE DATA

HEEL deg	T m	TR m	GZ m	AREA mrad
0.0	3.292	-0.377	-0.008	0.000
0.4	3.292	-0.377	0.000	0.000
10.0	3.223	-0.344	0.237	0.019
20.0	3.011	-0.238	0.501	0.084
30.0	2.688	-0.189	0.646	0.187
40.0	2.261	-0.348	0.627	0.300
50.0	1.759	-0.589	0.460	0.397
60.0	1.216	-0.823	0.210	0.456
70.0	0.644	-1.034	-0.084	0.467
80.0	0.071	-1.206	-0.379	0.427
90.0	-0.497	-1.432	-0.670	0.335

RELEVANT OPENINGS

NAME	TEXT	WT	X m	Y m	Z m	IMMA deg	IMMR m
ER_V_P	ER_INLET_P	UNPROTECTED	12.750	2.300	5.900	53.9	2.557
ER_V_S	ER_INLET_S	UNPROTECTED	12.750	-2.300	5.900	-	2.587
ER_O_P	ER_OUT_P	UNPROTECTED	14.000	2.300	7.900	68.1	4.572
ER_O_S	ER_OUT_S	UNPROTECTED	14.000	-2.300	7.900	-	4.602

LC03 - LC01+CRANE OPERATION(3T load)

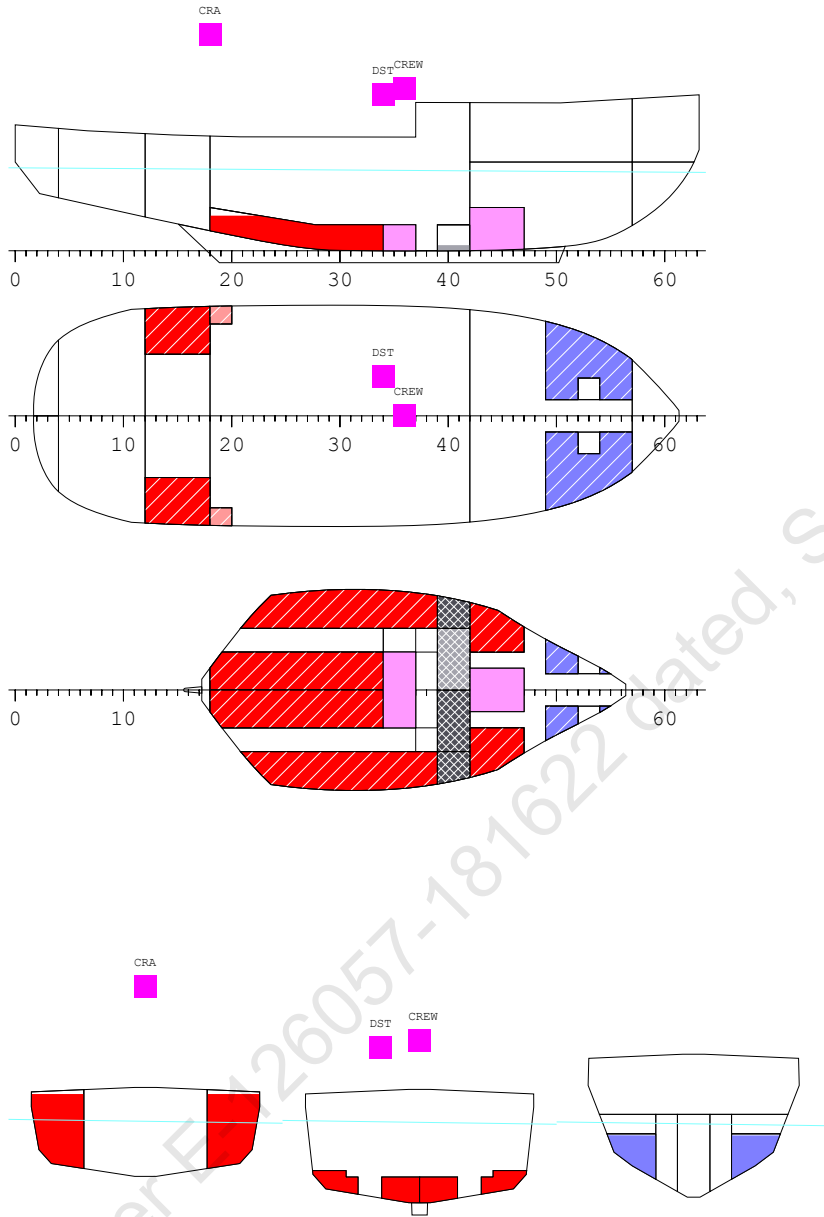

Fresh Water	Lubricating Oil	Sludge
Oil Spill Dispersant	Fire fighting Foam	Grey Water
Diesel Oil		

LC03 - LC01+CRANE OPERATION(3T load)

Floating Position - Intact condition

Draught at AP (moulded)	3.827 m
Draught at FP (moulded)	3.626 m
Mean Draught (moulded)	3.727 m
Trim (+ by Bow)	-0.201 m
Heel (+ PS)	0.8 deg
KM above moulded BL	5.523 m
KG above moulded BL	3.925 m
GM0 (solid)	1.597 m
Free Surface Correction	0.072 m
GM (liquid)	1.525 m
Density of Water	1.025 t/m3

LCB	:	15.670 m Fwd of AP
LCF	:	14.709 m Fwd of AP
MCT	:	6.163 tm/cm
TPC	:	2.893 t/cm

LOAD SUMMARY TABLE

NAME	LOAD	MASS t	LCG m	TCG m	VCG m
Crane	CRA	3.0	9.000	0.000	10.000
Crew	CREW	1.0	18.000	0.000	7.500
Oil Spill Dispersant	DISPERSANT	5.8	17.750	0.000	0.636
Diesel Oil	DO	98.4	12.536	0.000	1.965
Deck Store	DST	2.0	17.000	1.800	7.200
Fire fighting Foam	FOAM	9.4	22.239	0.000	1.043
Fresh Water	FW	30.5	26.028	0.000	2.251
Grey Water	GWT	0.4	20.224	0.598	0.155
Lubricating Oil	LO	4.4	9.505	0.000	3.686
Sludge	SLU	1.8	20.166	-0.338	0.372
Deadweight		156.6	15.982	0.021	2.198
Lightweight		550.2	15.595	0.015	4.417
Deadweight		156.6	15.982	0.021	2.198
Total weight		706.8	15.681	0.016	3.925

LOADING COMPONENTS

Diesel Oil (Density 0.860 t/m3)

NAME	PURP	FILL %	MASS t	VOL m3	LCG m	TCG m	VCG m	FRSM tm
R.FODAYTK.S	DO	95.0	18.2	21.1	7.543	-3.941	3.561	2.99
R.FODAYTK.P	DO	95.0	18.2	21.1	7.543	3.941	3.561	2.99
R.FOTK.2P	DO	95.0	12.9	15.0	14.195	3.792	1.209	4.23
R.FOTK.2S	DO	95.0	12.9	15.0	14.195	-3.792	1.209	4.23
R.FOTK.3P	DO	95.0	12.2	14.1	13.051	0.844	0.893	0.00
R.FOTK.3S	DO	95.0	12.2	14.1	13.051	-0.844	0.893	0.00
R.FOTK.1P	DO	95.0	6.0	7.0	22.155	2.887	1.394	0.00
R.FOTK.1S	DO	95.0	6.0	7.0	22.155	-2.887	1.394	0.00
TOTAL			98.4	114.5				14.44

Fresh Water (Density 1.0 t/m3)

NAME	PURP	FILL %	MASS t	VOL m3	LCG m	TCG m	VCG m	FRSM tm
R.FWTK.P	FW	95.0	15.2	15.2	26.041	2.086	2.297	8.80
R.FWTK.S	FW	95.0	15.2	15.2	26.041	-2.086	2.297	8.80
TOTAL			30.5	30.5				17.60

Lub Oil (Density 0.860 t/m3)

NAME	PURP	FILL %	MASS t	VOL m3	LCG m	TCG m	VCG m	FRSM tm
R.LOTK.P	LO	95.0	2.2	2.4	9.504	4.706	3.754	0.08
R.LOTK.S	LO	95.0	2.2	2.4	9.504	-4.706	3.754	0.08
TOTAL			4.4	4.8				0.16

FOAM (Density 1.0 t/m3)

NAME	PURP	FILL %	MASS t	VOL m3	LCG m	TCG m	VCG m	FRSM tm
R.FOAMTK	FOAM	100.0	9.4	9.4	22.239	0.000	1.043	1.63
TOTAL			9.4	9.4				1.63

DISPERSANT (Density 1.0 t/m3)

NAME	PURP	FILL %	MASS t	VOL m3	LCG m	TCG m	VCG m	FRSM tm
R.DISPERSANTTK	DISPERSANT	100.0	5.8	5.8	17.750	0.000	0.636	5.25
TOTAL			5.8	5.8				5.25

STORES

NAME	PURP	MASS t	LCG m	TCG m	VCG m
STORES	MASS	2.0	17.000	1.800	7.200
TOTAL		2.0	17.000	1.800	7.200

CREW

NAME	PURP	MASS t	LCG m	TCG m	VCG m
CREW	MASS	1.0	18.000	0.000	7.500
TOTAL		1.0	18.000	0.000	7.500

CRANE

NAME	PURP	MASS t	LCG m	TCG m	VCG m
CRANE-PAYLO.MASS		3.0	9.000	0.000	10.000
TOTAL		3.0	9.000	0.000	10.000

INTACT STABILITY CHECK PLOT

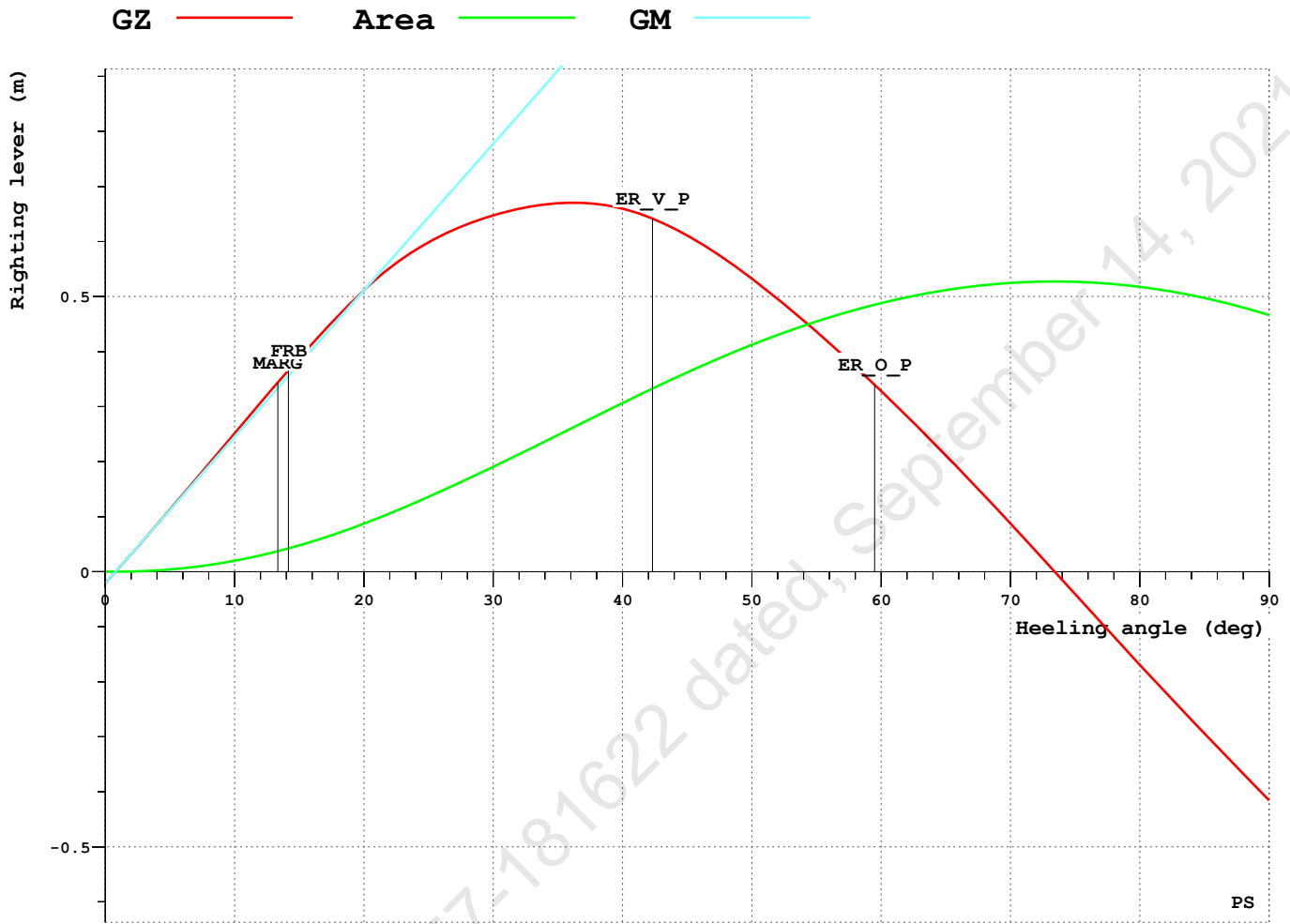

IMO WEATHER CRITERIA

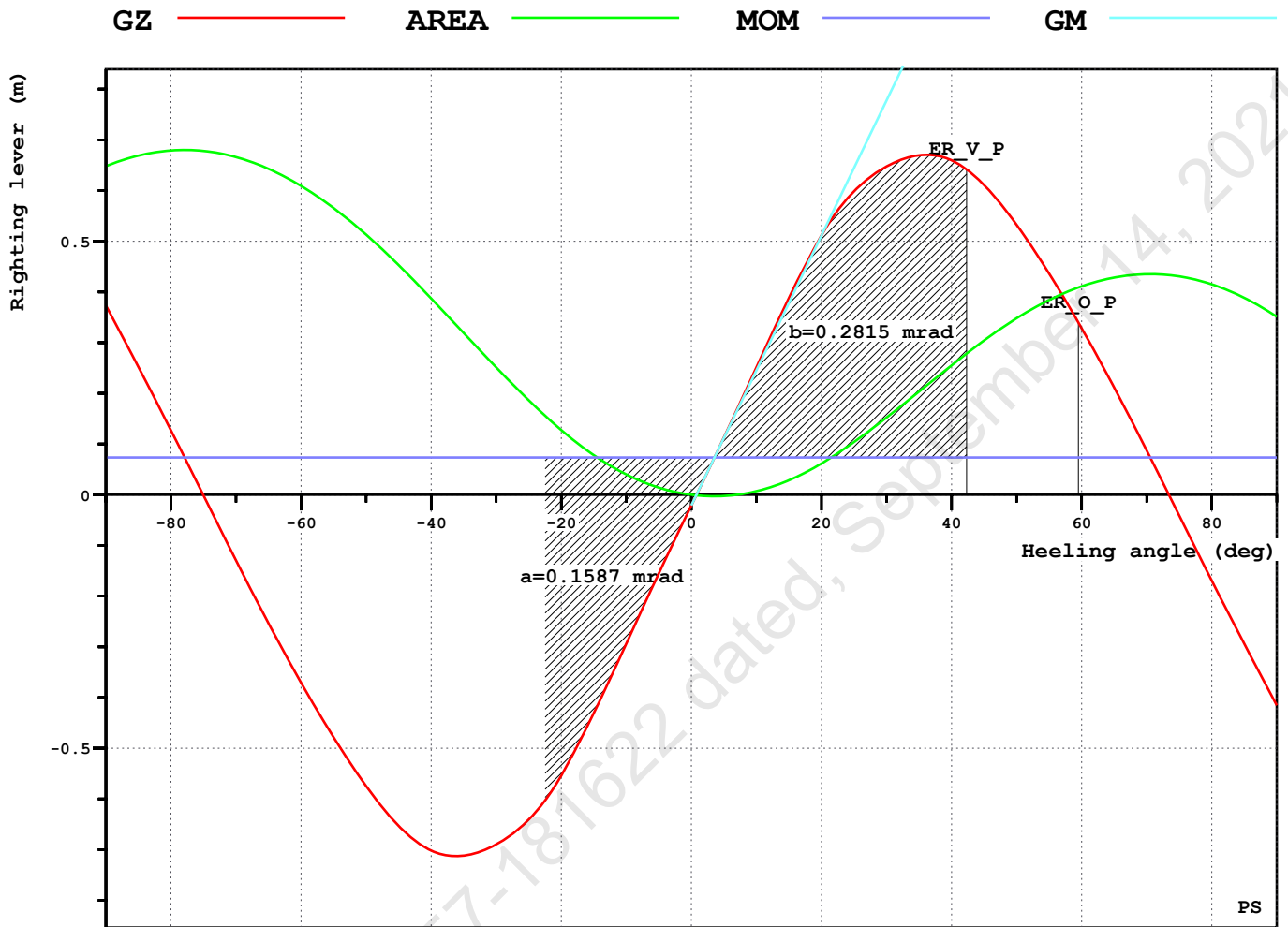

IS CODE LIFTING - Residual Area

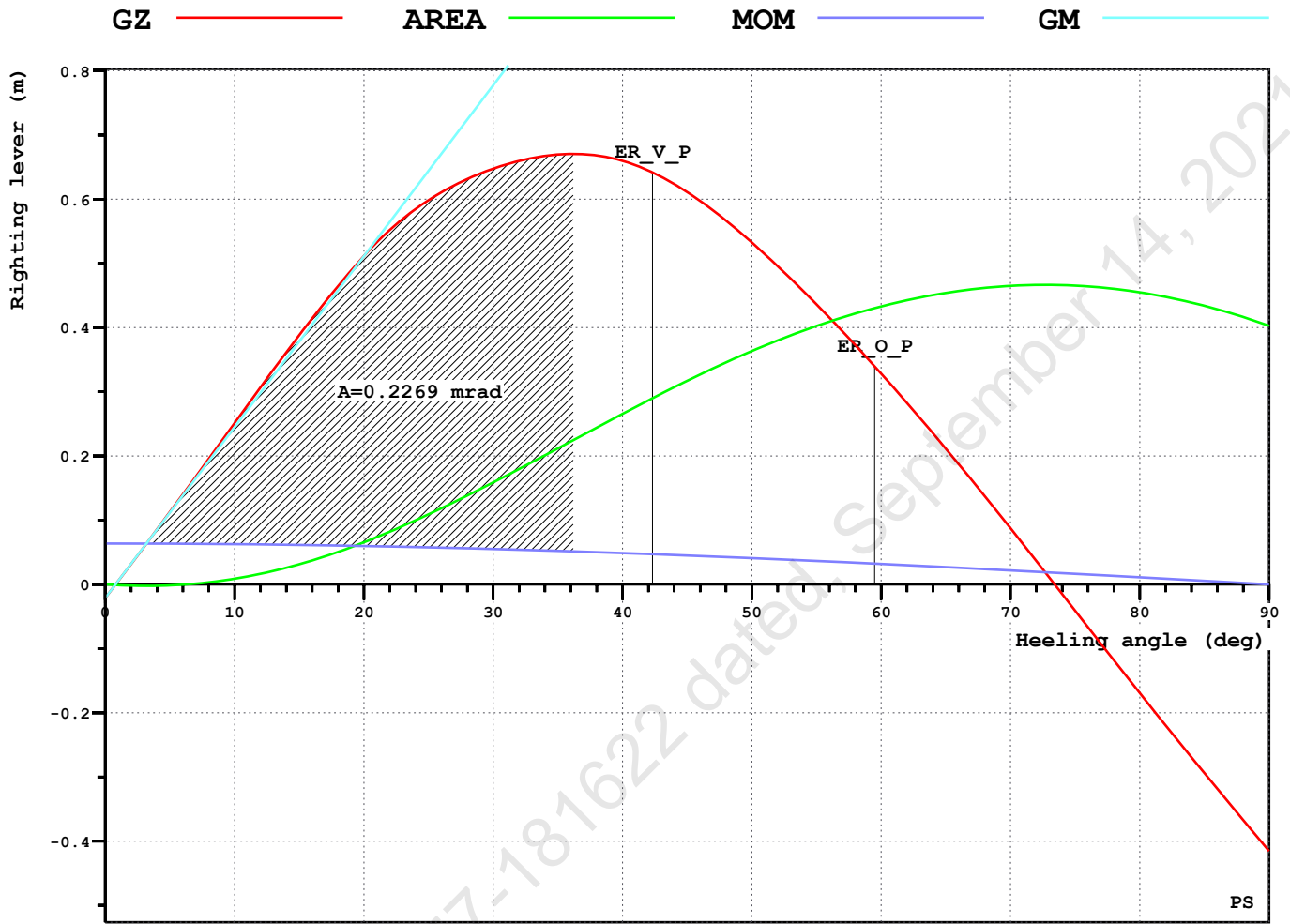

IS CODE LIFTING - Equilibrium angle

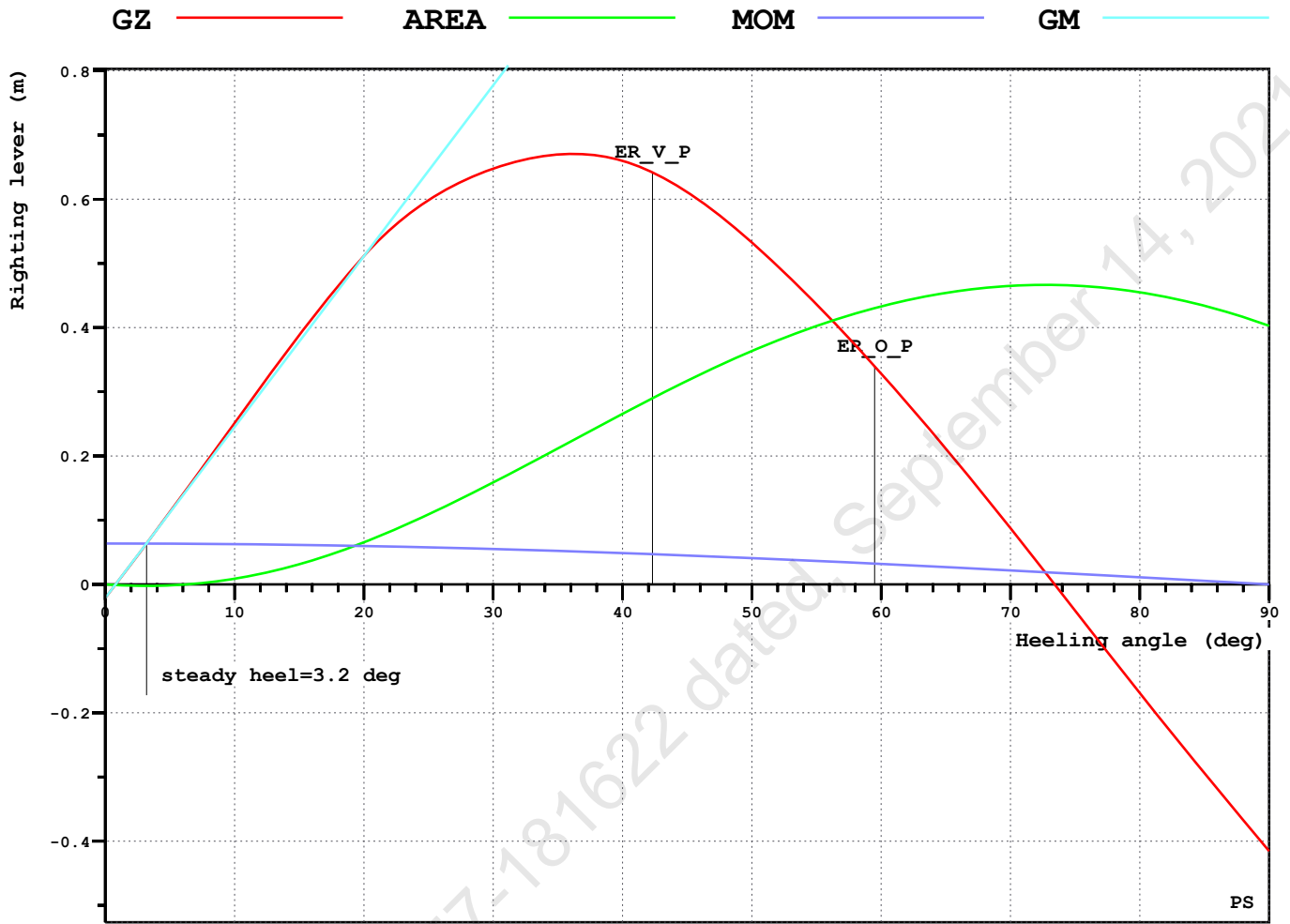

INTACT STABILITY CRITERIA

RCR	TEXT	REQ	ATTV	UNIT	STAT
AREA30	Area under GZ curve up to 30 deg.	0.055	0.191	mrاد	OK
AREA40	Area under GZ curve up to 40 deg.	0.090	0.307	mrاد	OK
AREA3040	Area under GZ curve btw. 30-40 deg.	0.030	0.116	mrاد	OK
GZ0.2	Max GZ > 0.2	0.200	0.670	m	OK
MAXGZ25	Max. GZ at an angle > 25 deg.	25.000	36.182	deg	OK
GM0.15	GM > 0.15 m	0.150	1.525	m	OK
V.IMOWEATHER	IMO weather criterion	1.000	1.774		OK
IMO.WIND_HEEL	Wind Heel <16 or <=80% of dk imm.	11.326	2.649	deg	OK
2020IS-B2.9.7.1.2	Eq. angle less than 10 deg. or dk. imm.	14.158	3.191	deg	OK
2020IS-B2.9.7.1.1	Resid. righting area > 0.08 mrad	0.080	0.227	mrاد	OK

Refer IRS Letter E-126057-181622 dated, September 14, 2021

GZ CURVE DATA

HEEL deg	T m	TR m	GZ m	AREA mrad
0.0	3.727	-0.202	-0.021	0.000
0.8	3.727	-0.202	0.000	0.000
10.0	3.653	-0.184	0.251	0.020
20.0	3.450	-0.170	0.512	0.087
30.0	3.180	-0.348	0.648	0.191
40.0	2.831	-0.695	0.660	0.307
50.0	2.409	-1.063	0.533	0.412
60.0	1.925	-1.404	0.328	0.488
70.0	1.395	-1.694	0.088	0.525
80.0	0.831	-1.919	-0.169	0.518
90.0	0.258	-2.065	-0.415	0.466

RELEVANT OPENINGS

NAME	TEXT	WT	X m	Y m	Z m	IMMA deg	IMMR m
ER_V_P	ER_INLET_P	UNPROTECTED	12.750	2.300	5.900	42.3	2.121
ER_V_S	ER_INLET_S	UNPROTECTED	12.750	-2.300	5.900	-	2.186
ER_O_P	ER_OUT_P	UNPROTECTED	14.000	2.300	7.900	59.5	4.129
ER_O_S	ER_OUT_S	UNPROTECTED	14.000	-2.300	7.900	-	4.194

LC04 - LC02+CRANE OPERATION(3T load)

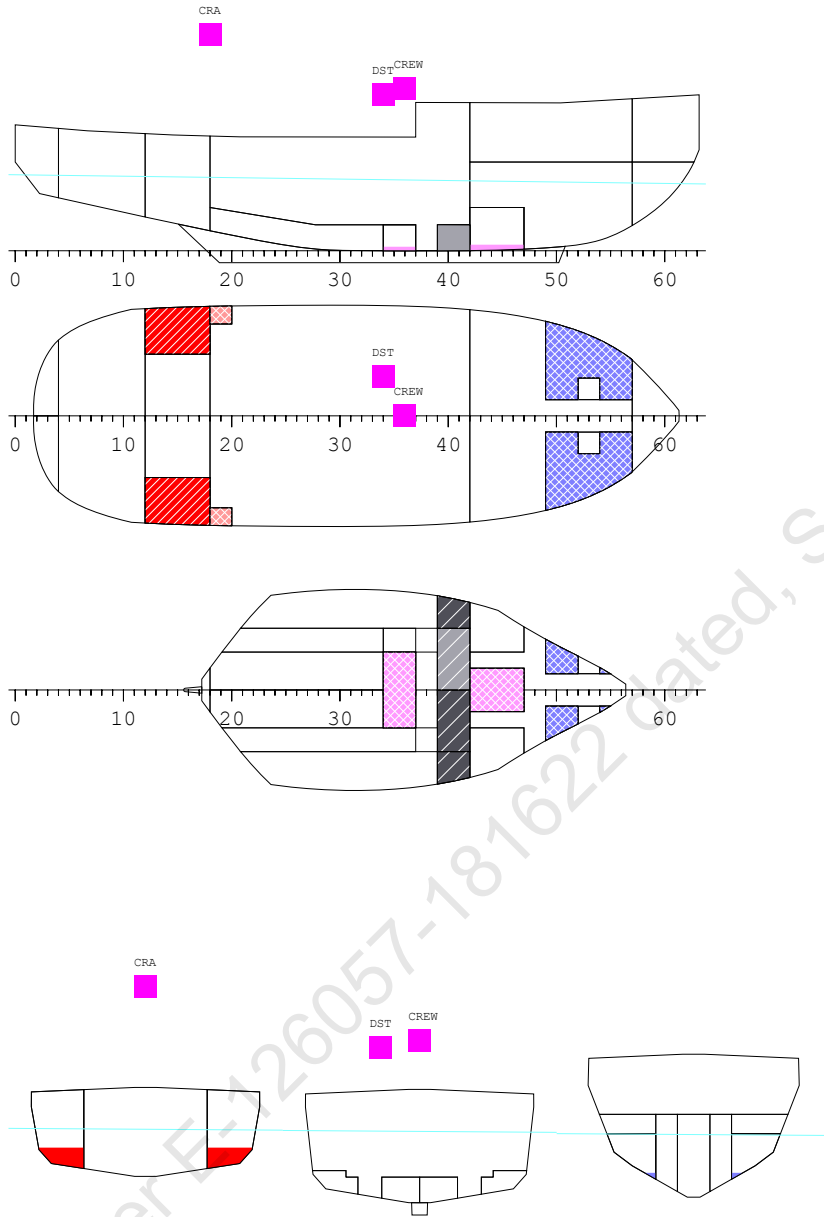

Fresh Water	Lubricating Oil	Sludge
Oil Spill Dispersant	Fire fighting Foam	Grey Water
Diesel Oil		

LC04 - LC02+CRANE OPERATION(3T load)

Floating Position - Intact condition

Draught at AP (moulded)	3.506 m
Draught at FP (moulded)	3.096 m
Mean Draught (moulded)	3.301 m
Trim (+ by Bow)	-0.410 m
Heel (+ PS)	0.4 deg
KM above moulded BL	5.681 m
KG above moulded BL	4.264 m
GM0 (solid)	1.418 m
Free Surface Correction	0.087 m
GM (liquid)	1.331 m
Density of Water	1.025 t/m <sup>3</sup>

LCB	:	15.659 m Fwd of AP
LCF	:	14.676 m Fwd of AP
MCT	:	5.628 tm/cm
TPC	:	2.783 t/cm

LOAD SUMMARY TABLE

NAME	LOAD	MASS t	LCG m	TCG m	VCG m
Crane	CRA	3.0	9.000	0.000	10.000
Crew	CREW	1.0	18.000	0.000	7.500
Oil Spill Dispersant	DISPERSANT	0.6	17.747	0.000	0.111
Diesel Oil	DO	7.6	7.730	0.000	2.142
Deck Store	DST	0.2	17.000	1.800	7.200
Fire fighting Foam	FOAM	0.9	22.139	0.000	0.173
Fresh Water	FW	3.2	25.334	0.000	1.081
Grey Water	GWT	3.9	20.242	1.279	0.668
Lubricating Oil	LO	0.5	9.540	0.000	2.394
Sludge	SLU	16.8	20.226	-0.724	0.833
Deadweight		37.7	17.042	-0.180	2.032
Lightweight		550.2	15.595	0.015	4.417
Deadweight		37.7	17.042	-0.180	2.032
Total weight		587.9	15.688	0.002	4.264

LOADING COMPONENTS

Diesel Oil (Density 0.860 t/m3)

NAME	PURP	FILL %	MASS t	VOL m3	LCG m	TCG m	VCG m	FRSM tm
R.FODAYTK.S	DO	20.0	3.8	4.4	7.543	-3.941	3.561	2.99
R.FODAYTK.P	DO	20.0	3.8	4.4	7.543	3.941	3.561	2.99
R.FOTK.2P	DO	0.0	0.0	0.0	14.195	3.792	1.209	4.23
R.FOTK.2S	DO	0.0	0.0	0.0	14.195	-3.792	1.209	4.23
R.FOTK.3P	DO	0.0	0.0	0.0	13.051	0.844	0.893	0.00
R.FOTK.3S	DO	0.0	0.0	0.0	13.051	-0.844	0.893	0.00
R.FOTK.1P	DO	0.0	0.0	0.0	22.155	2.887	1.394	0.00
R.FOTK.1S	DO	0.0	0.0	0.0	22.155	-2.887	1.394	0.00
TOTAL			7.6	8.9				14.44

Fresh Water (Density 1.0 t/m3)

NAME	PURP	FILL %	MASS t	VOL m3	LCG m	TCG m	VCG m	FRSM tm
R.FWTK.P	FW	10.0	1.6	1.6	26.041	2.086	2.297	8.80
R.FWTK.S	FW	10.0	1.6	1.6	26.041	-2.086	2.297	8.80
TOTAL			3.2	3.2				17.60

Lub Oil (Density 0.860 t/m3)

NAME	PURP	FILL %	MASS t	VOL m3	LCG m	TCG m	VCG m	FRSM tm
R.LOTK.P	LO	10.0	0.2	0.3	9.504	4.706	3.754	0.08
R.LOTK.S	LO	10.0	0.2	0.3	9.504	-4.706	3.754	0.08
TOTAL			0.5	0.5				0.16

FOAM (Density 1.0 t/m3)

NAME	PURP	FILL %	MASS t	VOL m3	LCG m	TCG m	VCG m	FRSM tm
R.FOAMTK	FOAM	10.0	0.9	0.9	22.239	0.000	1.043	1.63
TOTAL			0.9	0.9				1.63

DISPERSANT (Density 1.0 t/m3)

NAME	PURP	FILL %	MASS t	VOL m3	LCG m	TCG m	VCG m	FRSM tm
R.DISPERSANTTK	DISPERSANT	10.0	0.6	0.6	17.750	0.000	0.636	5.25
TOTAL			0.6	0.6				5.25

STORES

NAME	PURP	MASS t	LCG m	TCG m	VCG m
STORES	MASS	0.2	17.000	1.800	7.200
TOTAL		0.2	17.000	1.800	7.200

CREW

NAME	PURP	MASS t	LCG m	TCG m	VCG m
CREW	MASS	1.0	18.000	0.000	7.500
TOTAL		1.0	18.000	0.000	7.500

CRANE

NAME	PURP	MASS t	LCG m	TCG m	VCG m
CRANE	MASS	3.0	9.000	0.000	10.000
TOTAL		3.0	9.000	0.000	10.000

INTACT STABILITY CHECK PLOT

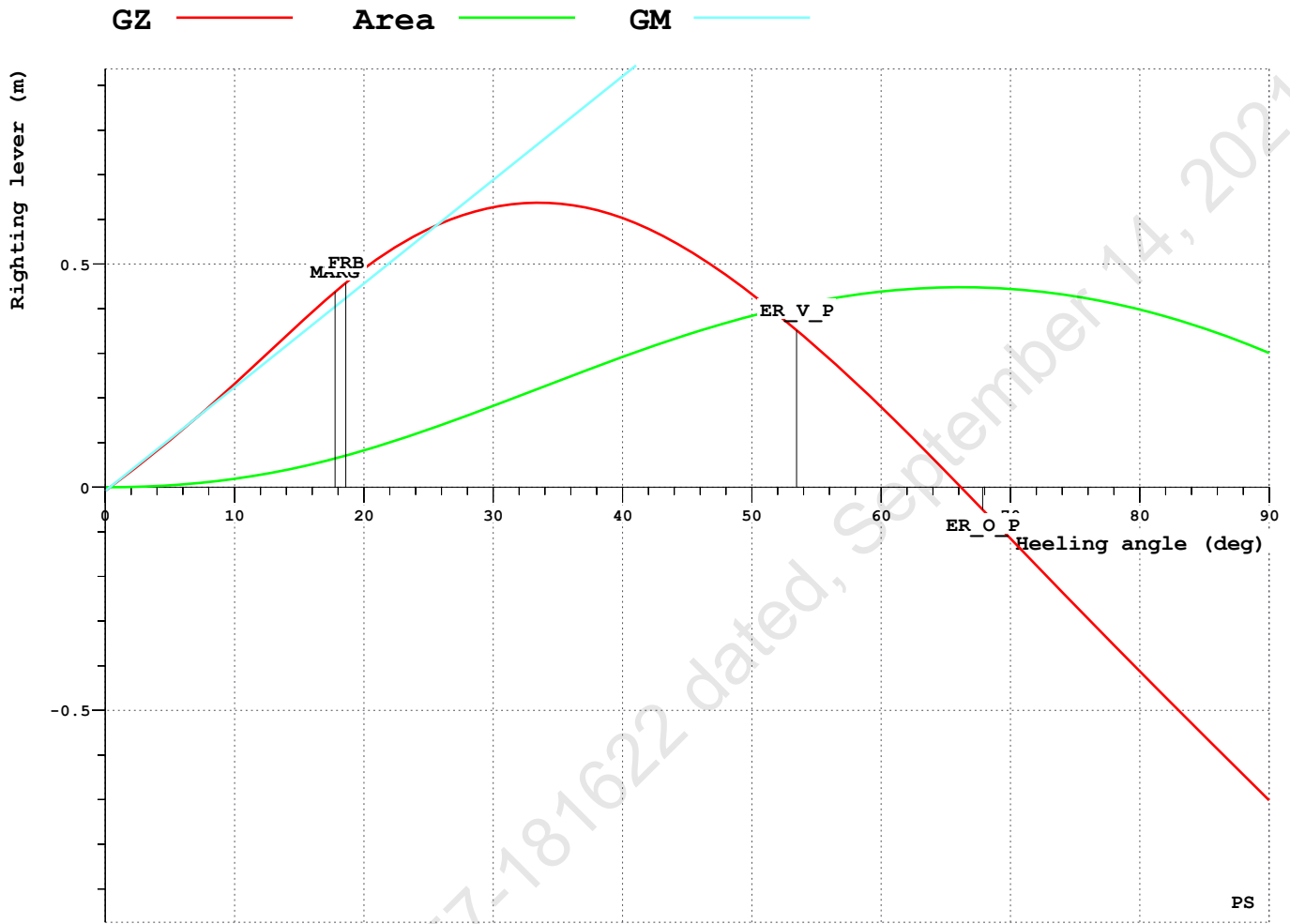

IMO WEATHER CRITERIA

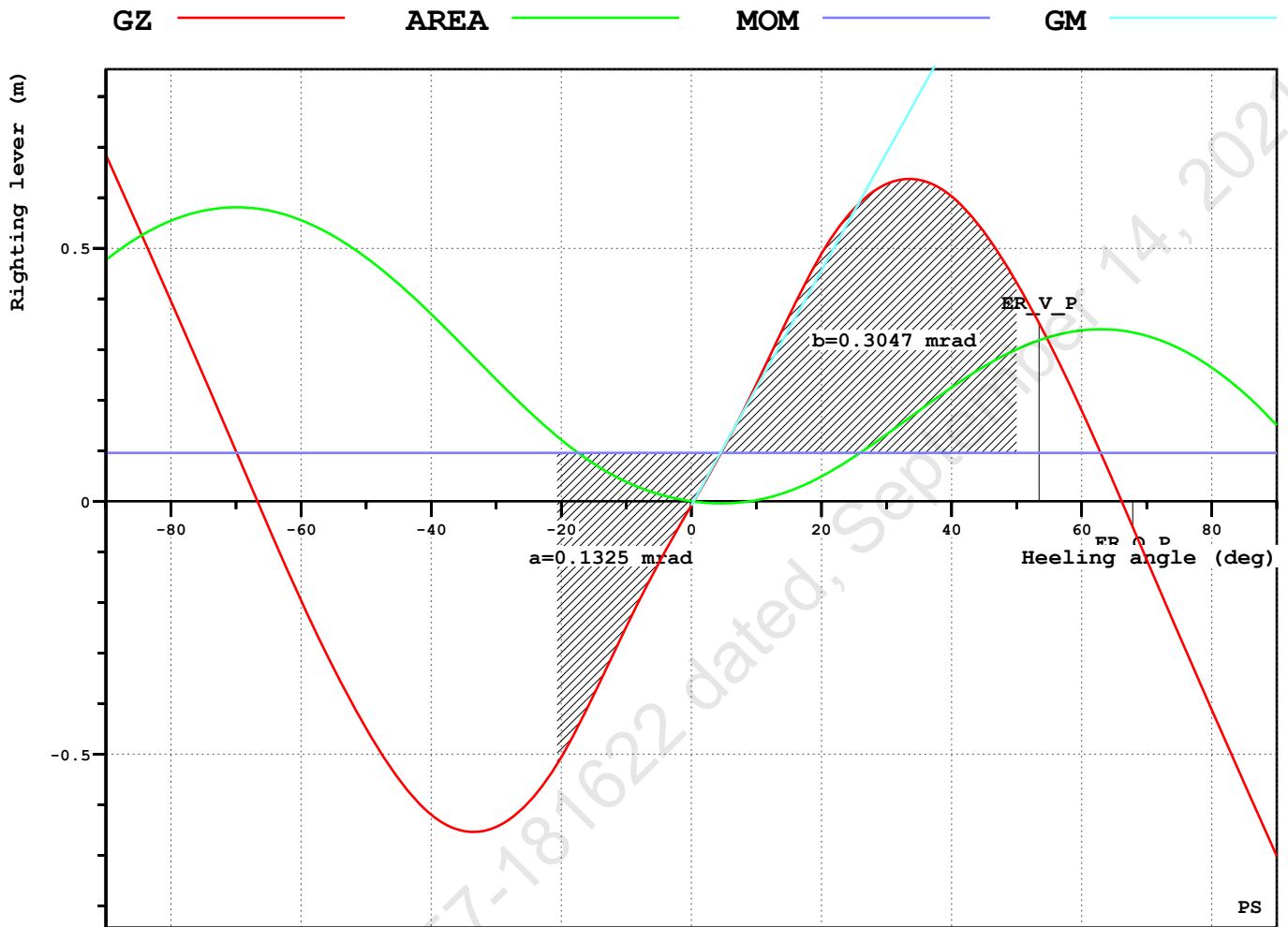

IS CODE LIFTING - Residual Area

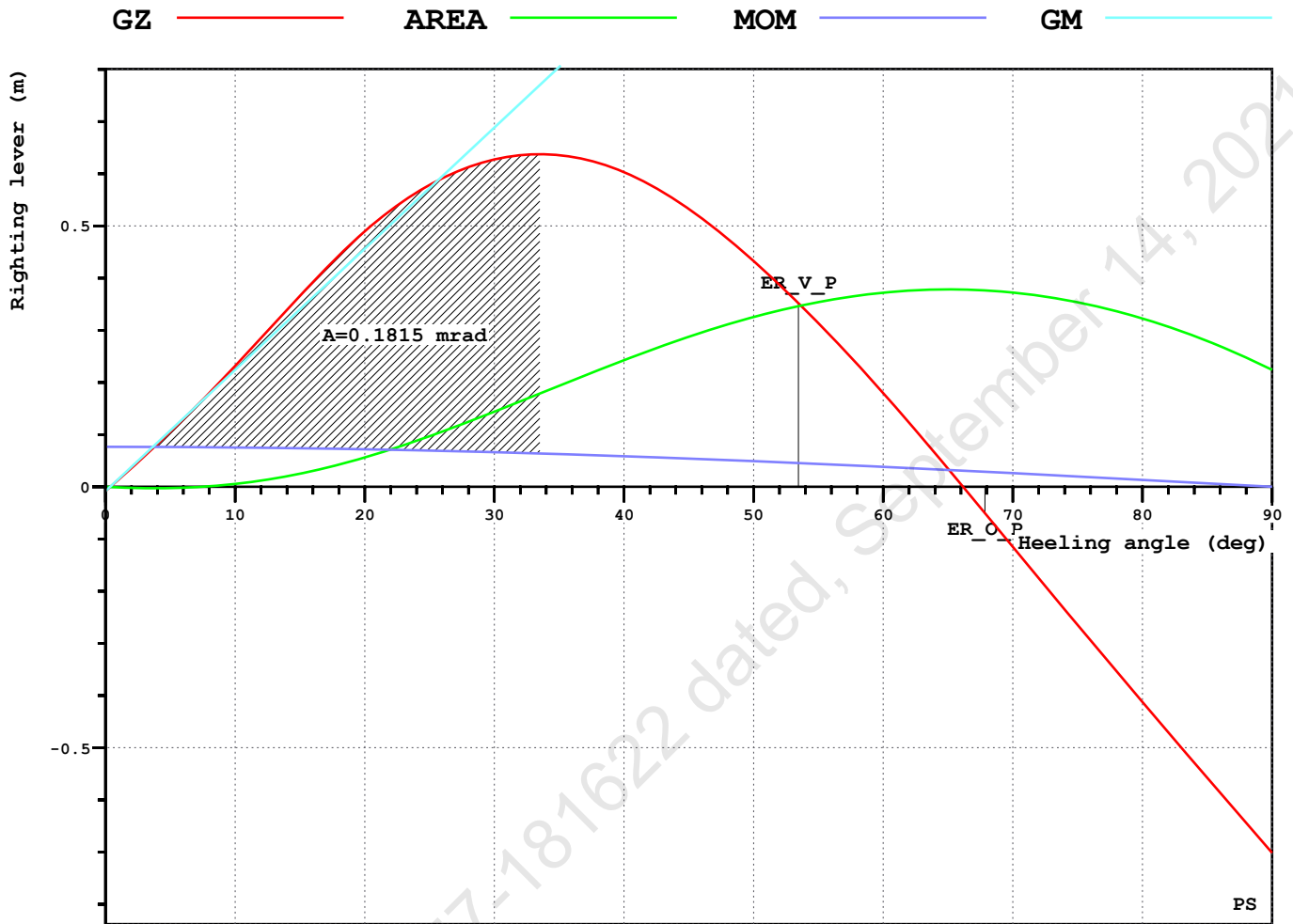

IS CODE LIFTING - Equilibrium angle

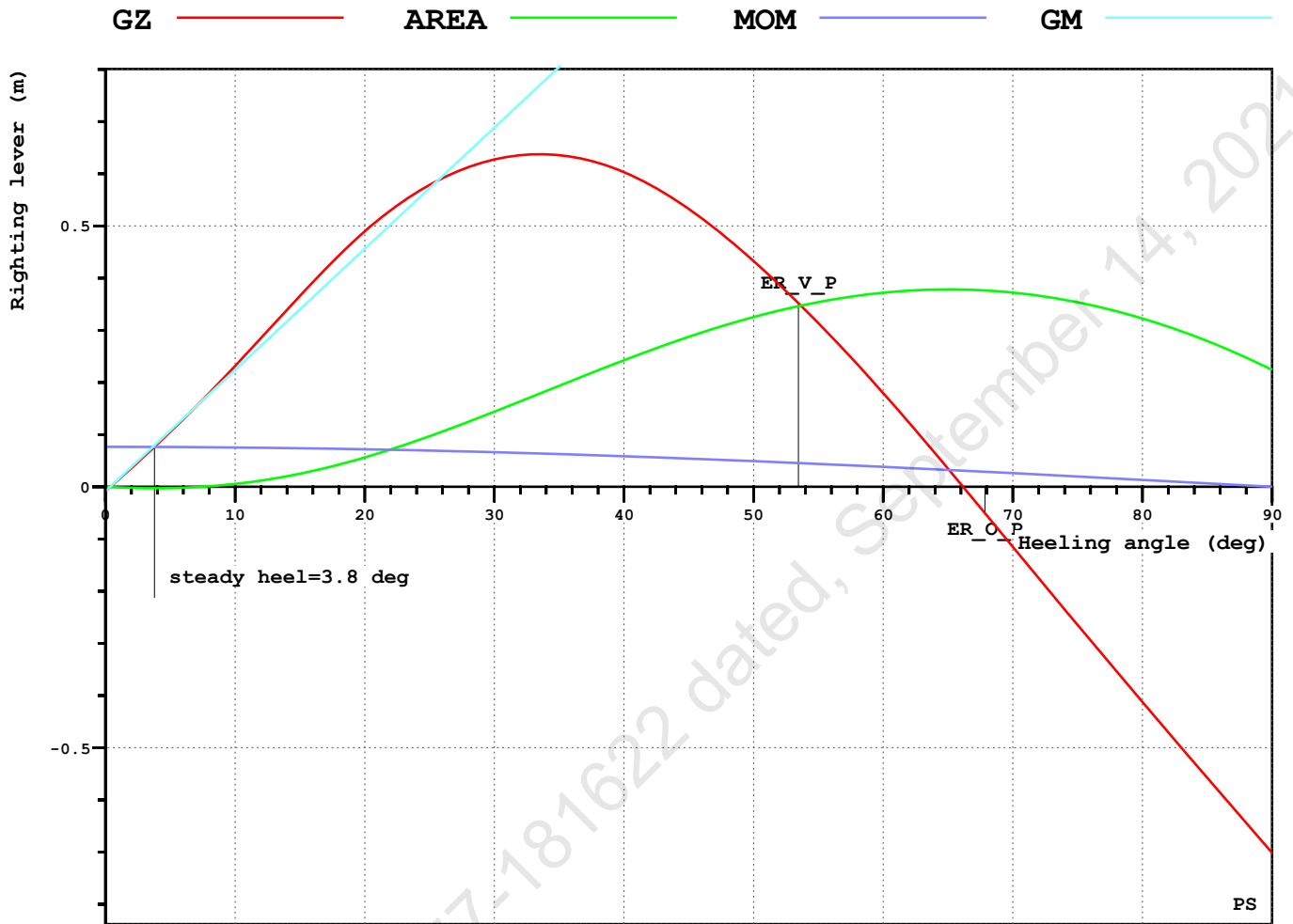

INTACT STABILITY CRITERIA

RCR	TEXT	REQ	ATTV	UNIT	STAT
AREA30	Area under GZ curve up to 30 deg.	0.055	0.182	mrاد	OK
AREA40	Area under GZ curve up to 40 deg.	0.090	0.292	mrاد	OK
AREA3040	Area under GZ curve btw. 30-40 deg.	0.030	0.110	mrاد	OK
GZ0.2	Max GZ > 0.2	0.200	0.637	m	OK
MAXGZ25	Max. GZ at an angle > 25 deg.	25.000	33.501	deg	OK
GM0.15	GM > 0.15 m	0.150	1.331	m	OK
V.IMOWEATHER	IMO weather criterion	1.000	2.299		OK
IMO.WIND_HEEL	Wind Heel <16 or <=80% of dk imm.	14.876	3.232	deg	OK
2020IS-B2.9.7.1.2	Eq. angle less than 10 deg. or dk. imm.	18.595	3.772	deg	OK
2020IS-B2.9.7.1.1	Resid. righting area > 0.08 mrad	0.080	0.181	mrاد	OK

Refer IRS Letter E-126057-181622 dated, September 14, 2021

GZ CURVE DATA

HEEL deg	T m	TR m	GZ m	AREA mrad
0.0	3.302	-0.410	-0.008	0.000
0.4	3.302	-0.410	0.000	0.000
10.0	3.232	-0.378	0.232	0.019
20.0	3.021	-0.274	0.490	0.082
30.0	2.701	-0.234	0.627	0.182
40.0	2.276	-0.403	0.603	0.292
50.0	1.777	-0.653	0.433	0.384
60.0	1.236	-0.894	0.180	0.438
70.0	0.665	-1.110	-0.115	0.444
80.0	0.092	-1.283	-0.412	0.398
90.0	-0.475	-1.509	-0.702	0.301

RELEVANT OPENINGS

NAME	TEXT	WT	X m	Y m	Z m	IMMA deg	IMMR m
ER_V_P	ER_INLET_P	UNPROTECTED	12.750	2.300	5.900	53.5	2.543
ER_V_S	ER_INLET_S	UNPROTECTED	12.750	-2.300	5.900	-	2.574
ER_O_P	ER_OUT_P	UNPROTECTED	14.000	2.300	7.900	67.8	4.560
ER_O_S	ER_OUT_S	UNPROTECTED	14.000	-2.300	7.900	-	4.590