



PLAN ENDORSED FOR IN-PRINCIPLE APPROVAL

SEE LETTER E-126289-181891

REVIEWED



17-SEP-2021



COCHIN SHIPYARD - CT3380
80 T BOLLARD PULL ASD TUG -
PRELIMINARY STABILITY REPORT

This design was developed by Cochin Shipyard Ltd. for Indian Ports Association as a part of ASTDS Package. CSL does not make any representation or warranties, express or implied as to the completeness, accuracy, suitability of the design and it shall be the responsibility of the respective builder/end-user to make its own assessment/evaluation of any such completeness, accuracy, suitability of the design prior to construction and any consequence thereof.

Revision No.	Date	Description	Sign
Rev. I	15 Sep 2021	For publishing on IPA website	ABK/HUR



TABLE OF CONTENTS

1. INTRODUCTION.....	1-1
2. VESSEL INFORMATION.....	2-1
4. GENERAL ARRANGEMENT	4-1
5. TOW POINT LOCATIONS	5-1
6. EXTERNAL FIFI ARRANGEMENT	6-1
7. OPENINGS	7-1
8. TANK PLAN.....	8-1
9. HYDROSTATIC DATA	9-1
10. CROSS CURVES.....	10-1
11. LOADING CONDITIONS	11-1

Refer IRS Letter E-126289-181891 dated, September 17, 2021



1. INTRODUCTION

This document summarizes the preliminary assessment of Intact Stability of 80 T Bollard Pull Tug variant for in-principle approval from Class. The stability of the vessel is checked against the requirement as per Intact Stability Code 2008.

Stability of the vessel during towing operation is checked as per amendment to part B of IS Code 2008, vide MSC Resolution 415(97), Section 2.8 – Ships Engaged in Towing Operations.

Stability of the vessel during FiFi operation is checked as per DNV RU-Ship, Part 5, Chapter 10, and Section 9. Overturning moment is calculated assuming that all the fire monitors are operated at their full capacity in transverse direction.

Only most onerous conditions are described in this stability report. Detailed stability booklet including all the necessary loading conditions, hydrostatics, cross curves etc. to the satisfaction of Class and regulatory authorities shall be submitted to class for approval by the builder during the time of vessel construction.

Stability calculations are performed in NAPA 2020.2-1 software.



2. VESSEL INFORMATION

The vessel shall be primarily tasked for ship handling and towing operations including berthing/unberthing, push pull, etc.

The vessel shall have unrestricted sea going capability.

The vessel shall have a static bollard pull of at least 80 tonnes at 100 % MCR of the engine in ahead condition.

Main Particulars

Length overall	abt. 33.0 m
Length between perpendiculars	abt. 31.3 m
Breadth moulded	abt. 11.9 m
Depth midships	abt. 5.4 m
Hull Draught	abt. 4.2 m
Max. Draught	abt. 5.4 m
Gross tonnage	<500 GT
Complement	14 Nos.
Class Notation	IRS - 舩 SUL, 舩 IY, TUG, AGNI 1 (2400 m ³ /hr)



3. INTACT STABILITY CRITERIA

3.1 GENERAL CRITERIA (as per IS Code 2008 Ch. 2, 2.2)

- The area under the righting lever curve (GZ curve) shall not be less than 0.055 m-rad up to $\approx 30^\circ$
- Area under GZ Curve shall not be less than 0.09 m-rad up to 40° or the angle of down-flooding, whichever is lesser.
- Area under GZ Curve between the angles of heel of 30° and lesser of 40° or the angle of down-flooding shall not be less than 0.03 m-rad.
- The righting lever GZ shall be at least 0.2 m at an angle of heel equal to or greater than 30°
- The initial metacentric height GM_0 shall not be less than 0.15 m.
- The maximum righting lever shall occur at an angle of heel not less than 25° .

3.2 SEVERE WIND AND ROLLING CRITERIA (as per IS Code 2008 Ch. 2, 2.3)

Ability of the ship to withstand combined effects of beam wind and rolling shall be demonstrated as follows, when subjected to wind loads as per IS Code Ch. 2, 2.3:

- Area b shall be equal to or greater than area a
- The angle of heel under action of steady wind should not exceed 16° or 80% of the angle of deck edge immersion, whichever is less.

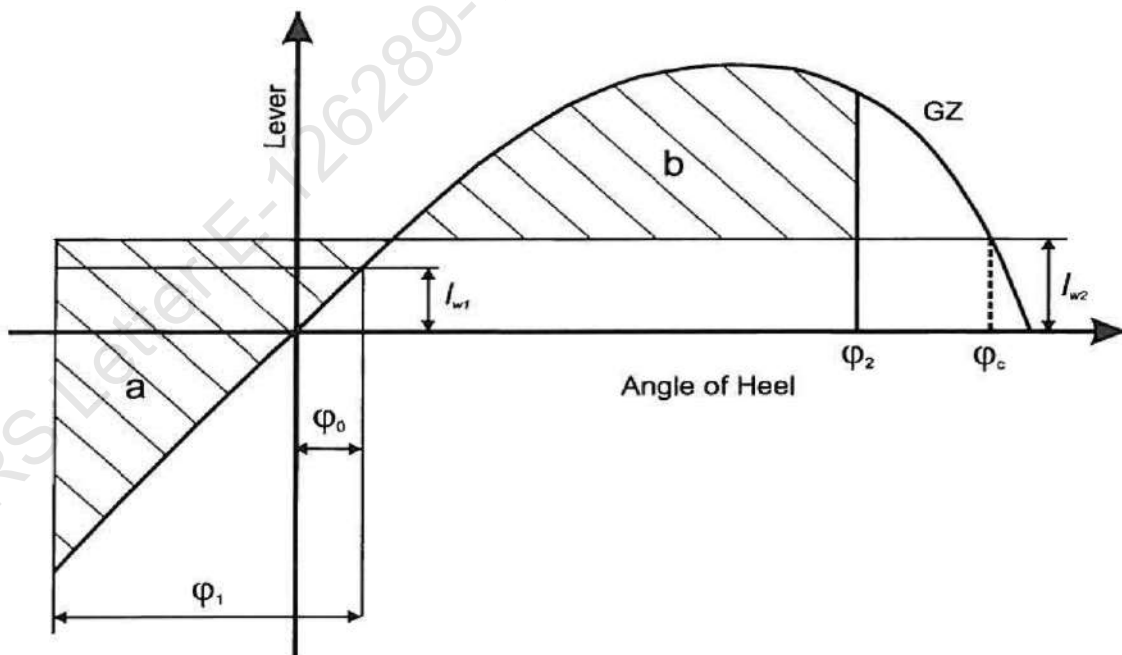

Figure 1 Severe Wind & Rolling Criteria



3.3 STABILITY CRITERIA FOR TOWING (as per IS Code 2008, Ch.2, 2.8)

Stability of the vessel during towing operation has been checked iaw IS Code 2008, Ch. 2, 2.8.

- The area A between the righting lever curve and the heeling lever curve for self-tripping calculated iaw. 2.8.2.1 of IS Code, measured from equilibrium heel angle, (ϕ_e) to the angle of the second intersection, (ϕ_c) or the angle of down-flooding, (ϕ_f) whichever is less, should be greater than the area B contained between the heeling lever curve and the righting lever curve, measured from the heel angle $\phi=0$ to equilibrium heel angle (ϕ_e).
- The first intersection between the righting lever curve and the heeling lever curve for tow-tripping calculated iaw 2.8.2.2 should occur at an angle of heel less than the angle of down-flooding (ϕ_f).

Moment Calculation:

The location of propulsion units and towing point used for moment calculation are as indicated in Chapter 5-Tow Point Locations.

a. Self-Tripping Heeling Lever

$$HL_{\phi} = \frac{BP \times C_T \times (h \times \cos\phi - r \times \sin\phi)}{g \times \Delta}$$

Where:

BP	bollard pull of the vessel in (kN) – 784.8 kN	
C_T	0.5, for ships with conventional, non-azimuth propulsion units; 0.90/(1 + l/L _{LL}) for ships with azimuth propulsion units installed at a single point along the length. CT should not be less than 0.7 for ships with azimuth stern drive towing over the stern or tractor tugs towing over the bow, and not less than 0.5 for ships with azimuth stern drive towing over the bow or tractor tugs towing over the stern;	
Δ	displacement, in (t);	
l	longitudinal distance, in (m), between the towing point and the vertical centreline of the propulsion unit(s) relevant to the towing situation considered;	
h	vertical distance, in (m), between the towing point and the horizontal centreline of the propulsion unit(s) as relevant for the towing situation considered;	
r	transverse distance, in (m), between the centre line and the towing point, to be taken as zero when the towing point is at the centre line.	
L _{LL}	length (L) as defined in the International Convention on Load Lines in force.	

b. Tow Tripping Heeling Lever

$$HL_{\phi} = \frac{C_1 \times C_2 \times \gamma \times V^2 \times A_p \times (h \times \cos\phi - r \times \sin\phi + C_3 \times d)}{2 \times g \times \Delta}$$

Where:

C_1	Lateral traction coefficient- 2.8 $\frac{L_S}{L_{PP}} - 0.1$	$0.10 \leq C_1 \leq 1.00$
-------	--	---------------------------



C_2	Correction of C_1 for angle of heel = $\frac{\varphi}{3 \varphi_D} + 0.5$	$C_2 \geq 1.00$
φ_D	Angle to deck edge = $\tan^{-1} \frac{2f}{B}$	
C_3	Distance from the center of A_p to the waterline as fraction of the draught related to the heeling angle = $\frac{\varphi}{\varphi_D} \times 0.26 + 0.30$, $0.50 \leq C_3 \leq 0.83$	
γ	Specific gravity of water, in (t/m ³);	
V	Lateral velocity, in (m/s), to be taken as 2.57 (5 knots);	
A_p	Lateral projected area, in (m ²), of the underwater hull;	
r	the transverse distance, in (m), between the center line and the towing point, to be taken as zero when the towing point is at the center line;	
L_S	The longitudinal distance, in (m), from the aft perpendicular to the towing point;	
L_{PP}	Length between perpendiculars, in (m);	
φ	Angle of heel;	
f	Freeboard amidship, in (m);	
B	Moulded breadth, in (m);	
h	Vertical distance, in (m), from the waterline to the towing point;	
d	Actual mean draught, in (m);	

3.4 STABILITY CRITERIA FOR CRANE OPERATION (as per IS Code 2008, Ch.2, 2.9)

Stability of the vessel has been checked for a heeling moment calculated iaw IS Code 2.9.6, the vessel has to meet the below stability criteria, as per IS Code 2.9.7.

- The residual righting area below the righting lever and above the heeling lever curve between ϕ_e and the lesser of 40° or the angle of the maximum residual righting lever should not be less than 0.080 m rad.
- The equilibrium angle is to be limited to 10 degrees or the angle of immersion of the highest continuous deck enclosing the watertight hull.

The heeling lever should be calculated using the following formulae:

$$HL_{\varphi} = \frac{P_L \times y \times \cos \varphi}{\Delta}$$

where:

- P_L vertical load, in (t), of the lift, 3 t
- y transverse distance, in (m), of the lift, 15.0 m.
- φ angle of heel;
- HL_{φ} the heeling lever, in (m) due to the lift at ϕ ; and
- Δ the displacement, in (t) of the ship with the load of the lift.



3.5. STABILITY CRITERIA DURING EXTERNAL FiFi OPERATIONS (as per DNV GL, Rules for Fire Fighters)

Stability of the vessel during FiFi operation is checked as per DNV Part 5 Ch.10. Section 9, 9.1.3.

The monitor heeling lever (F), shall be less 0.5 times the maximum GZ corresponding to maximum allowable VCG. If the maximum GZ occurs after 30°, the GZ at 30° shall be used instead of the maximum GZ.

Heeling moment is calculated with all the fire monitors operating at their full capacity in transverse direction. The calculation is as below:

$$HL = \frac{F \times a}{\Delta}$$

- F heeling force, assumed in transverse direction based on the full capacity of the fire monitors, $n \times R$
- n Number of monitors, 2 Nos.
- R Reaction force from one monitor, when operating in transverse direction, 16.5 kN*
- a Monitor heeling arm, taken as the vertical distance between the centre of the thruster and the centreline of the monitor, 10.221 m

* Indicative Reaction force from monitor - Estimated based available data at this point. The builder/designer to estimate actual reaction based on binding data from OEMs during construction stage.



4. GENERAL ARRANGEMENT

Ref. drawing number CT3380-101-001 General Arrangement.

Refer IRS Letter E-126289-181891 dated, September 17, 2021



5. TOW POINT LOCATIONS

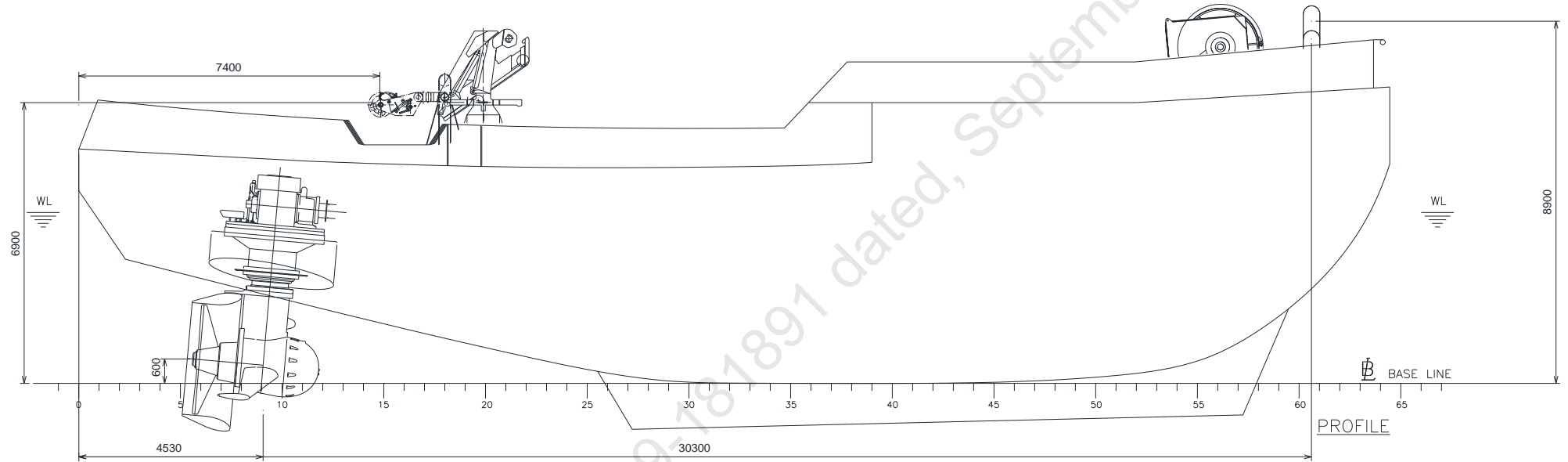



6. EXTERNAL FIFI ARRANGEMENT

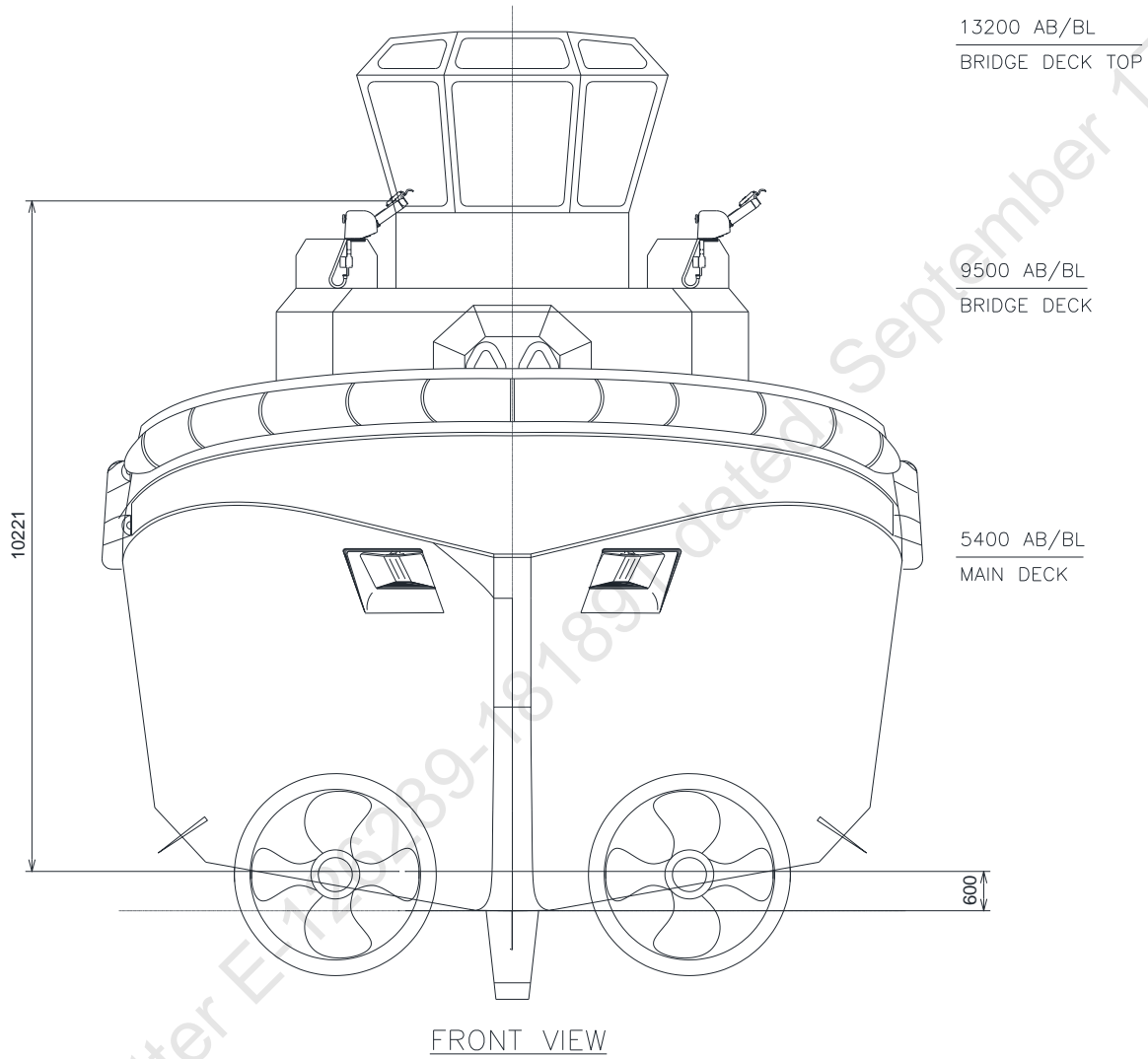



7. OPENINGS

The position of the lower corner farthest from the centreline of the ER ventilation are as below:

Name	Length to Fr. 0 [m]	Dist. From C.L [m]	Height from Baseline [m]	Opening Type
ER – Supply “PS/SB”	12.37	2.3	6.3	Unprotected
ER – Out “PS/SB”	14.0	1.5	8.4	Unprotected

Note:

Openings required for continuous supply to Engine room which are not conforming to ICLL Reg. 17(3) may be accepted subject to provision of alternate arrangements below and concurrence of flag.

- a. Shall be considered as unprotected openings in the stability calculation.
- b. Suitable weathertight closing arrangements shall be provided for the ventilators.
- c. Louvre shall have a coaming height of not less than 900 mm above main deck.
- d. Suitable drain shall be provided in way of the ventilators.

It shall be the responsibility of the respective builder/designer to get approval from Class/Flag for the alternate arrangements for lower coaming heights.



8. TANK PLAN

Refer IRS Letter E-126289-181891 dated, September 17, 2021

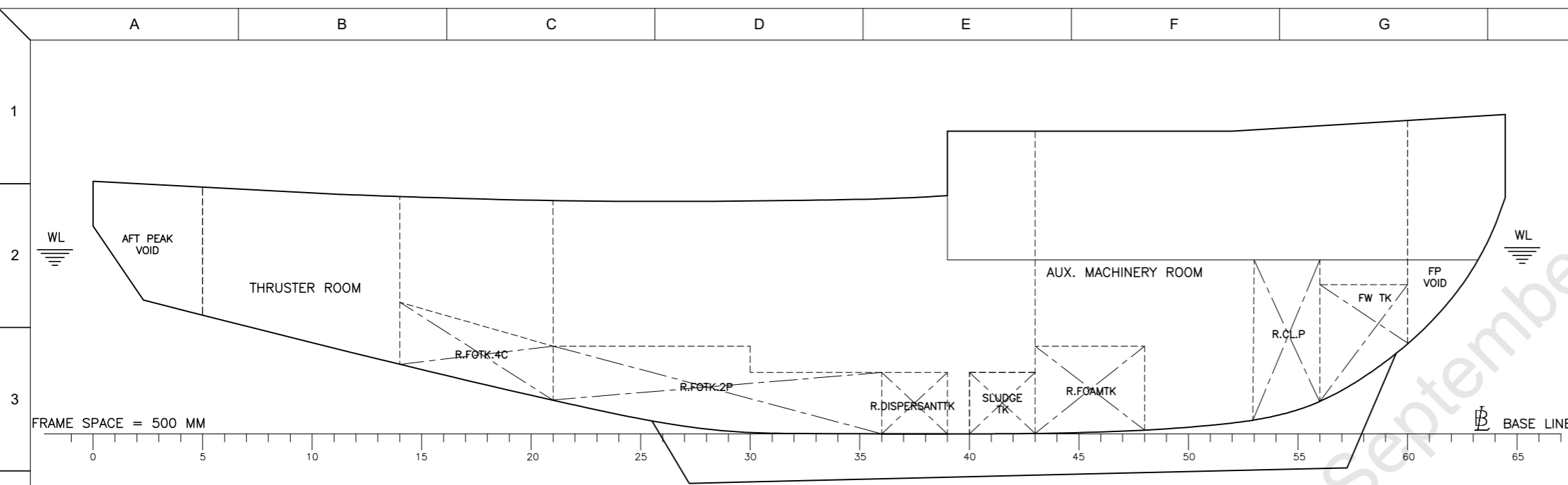

PROFILE

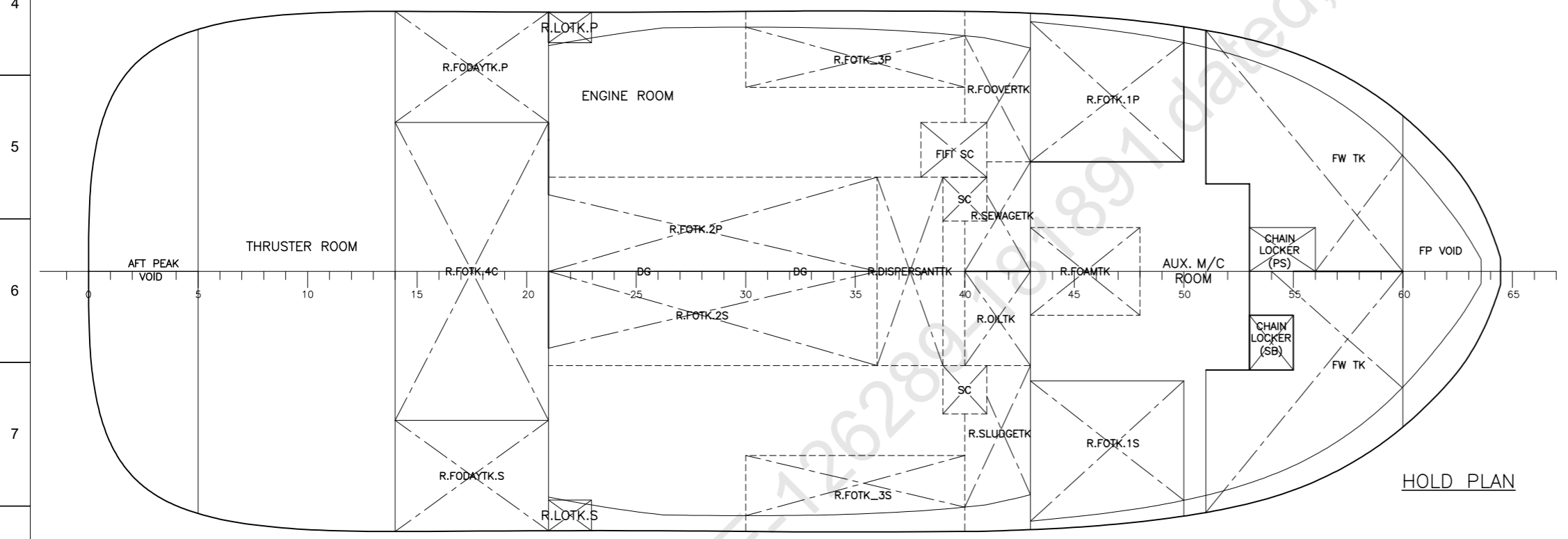

HOLD PLAN

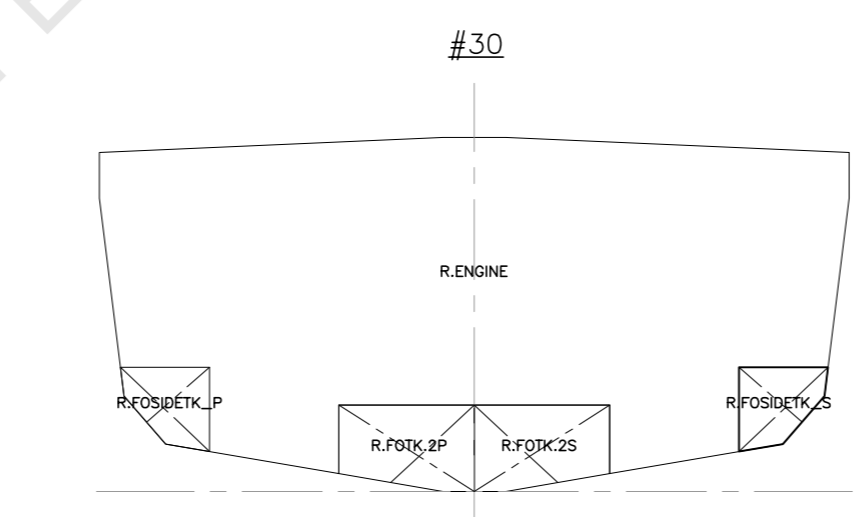
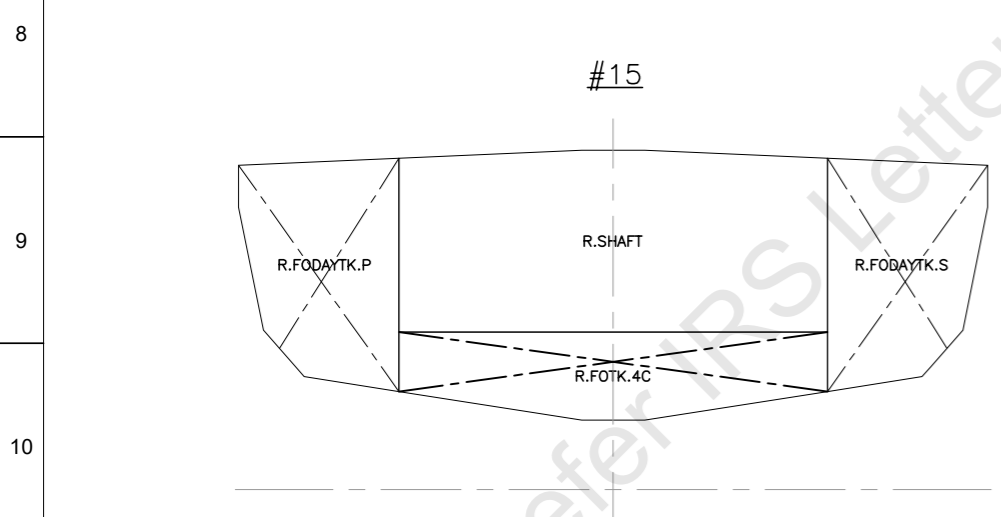

NAME	PURPOSE	DESCRIPTION	NET VOL (m³)	CGX (m)	CGY (m)	CGZ (m)	FSM
DIESEL OIL TANKS							
R.FODAYTK.P	DO	Diesel Oil	29.5	8.8	4.5	3.8	4.1
R.FODAYTK.S	DO	Diesel Oil	29.5	8.8	-4.5	3.8	4.1
R.FOTK.1S	DO	Diesel Oil	19.0	23.1	-3.7	2.3	5.7
R.FOTK.1P	DO	Diesel Oil	19.0	23.1	3.7	2.3	5.7
R.FOTK.2P	DO	Diesel Oil	23.0	14.2	1.0	1.0	5.2
R.FOTK.2S	DO	Diesel Oil	23.0	14.2	-1.0	1.0	5.2
R.FOTK.3P	DO	Diesel Oil	6.8	17.4	4.8	1.4	0.9
R.FOTK.3S	DO	Diesel Oil	6.8	17.4	-4.8	1.4	0.9
R.FOTK.4C	DO	Diesel Oil	26.6	8.7	0.0	1.9	76.6
Total :			183.3	m³			
FRESH WATER TANKS							
R.FWTK.P	FW	Fresh Water	16.9	27.6	1.9	2.6	16.6
R.FWTK.S	FW	Fresh Water	17.1	27.6	-1.7	2.5	19.9
Total :			34.0	m³			
MISC. TANKS							
R.LOTK.P	LO	Lubricating Oil	2.3	11.0	5.4	4.1	0.1
R.LOTK.S	LO	Lubricating Oil	2.3	11.0	-5.4	4.1	0.1
R.DISPERSANTTK	DISPERSANT	Oil Spill Dispersant	8.1	18.7	0.0	0.8	9.7
R.FOAMTK	FOAM	Fire fighting Foam	9.4	22.7	0.0	1.0	1.6
R.SLUDGETK	SLU	Sludge	4.0	20.8	-3.8	1.3	5.5
R.OJTK	SLU	Oily Water	4.0	20.7	-1.0	0.8	3.0
R.FOVERTK	SLU	Fuel Oil Over Flow	3.6	20.8	3.9	1.4	3.7
R.SEWAGETK	GWT	Grey Water	3.7	20.8	1.0	0.8	1.5



MAIN PARTICULARS

LENGTH O.A.....	abt 33.0 [m]
LENGTH B.P.....	abt 31.3 [m]
BREADTH (MLD).....	abt 11.9 [m]
DEPTH (MLD).....	abt 5.4 [m]
DRAFT (HULL).....	abt 4.2 [m]
COMPLEMENT.....	14 PERSONS
BOLLARD PULL	80 T @100% MCR
INSTALLED POWER	abt 4800 [kW]
CLASS NOTATION.....	IRS - SWASTIKA SUL,TUG SWASTIKA IY,AGNI 1 (2400m³/hr)

Rev. I	15 Sep 2021	For Publishing on IPA Website	VKM	ABK	HUR
No:	Date	Description	Drawn	Checked	Approved
ASTDS		80T BP TUG			
DESIGN NO : CT3380		TITLE			
		TANK PLAN			
COCHIN SHIPYARD LIMITED		1:120	A3	CT3380	CT3380-101-007
P.O. Bag 1653, COCHIN-682015, INDIA		Scale	Format	Project No.	Dwg. no.

This design was developed by Cochin Shipyard Ltd. for Indian Ports Association as a part of ASTDS Package. CSL does not make any representation or warranties, express or implied as to the completeness, accuracy, suitability of the design and it shall be the responsibility of the respective builder/end-user to make its own assessment/evaluation of any such completeness, accuracy, suitability of the design prior to construction and any consequence thereof.

9 HYDROSTATIC DATA

MAIN CHARACTERISTICS OF THE VESSEL:

Length between perpendiculars	31.33	m
Breadth (moulded)	11.78	m
Design draught (moulded)	4.20	m
X-coordinate of aft perpendicular	0.40	m
X-coordinate of reference point (XREF)	16.07	m
X-coordinate of midship section (XMID)	16.52	m
Thickness of keelplate	0.012	m
Mean thickness of shell plating	0.010	m
Seawater density	1.025	ton/m3

Calculations are based on STABHULL date 2021-08-25 time 10:57

Shell thickness used in the calculation	10.0	mm
X-coord. of aft end of DWL	0.37	m
X-coord. of fore end of DWL	31.74	m

Calc. sections	63	
Plate thickness	10.0	mm

EXPLANATION OF SYMBOLS:

T	Draught (moulded)	m
TK	Draught below keel	m
DISP	Total displacement	t
LCB	longitudinal centre of buoyancy	m
VCB	Vertical center of buoyancy	m
LCF	Longitudinal centre of flotation	m
KMT	Transverse metacentric height	m
MCT	Moment to change trim	tm/cm
TPC	change of displacement/change of draught	t/cm

Trim by BOW : +ve
X = 0 at TRANSOM

Trim: 0 m

T m	TK m	DISP t	LCB m	VCB m	LCF m	KMT m	MCT tm/cm	TPC t/cm
3.000	3.012	529.5	17.005	1.849	15.563	6.918	5.2	2.9
3.050	3.062	544.1	16.966	1.880	15.497	6.876	5.3	2.9
3.100	3.112	558.8	16.926	1.912	15.436	6.841	5.5	3.0
3.150	3.162	573.7	16.887	1.943	15.382	6.809	5.6	3.0
3.200	3.212	588.8	16.848	1.975	15.338	6.777	5.7	3.0
3.250	3.262	603.9	16.810	2.006	15.295	6.750	5.8	3.0
3.300	3.312	619.2	16.773	2.037	15.276	6.713	5.9	3.1
3.350	3.362	634.5	16.737	2.068	15.268	6.671	6.0	3.1
3.400	3.412	649.9	16.702	2.099	15.261	6.631	6.1	3.1
3.450	3.462	665.4	16.669	2.130	15.254	6.595	6.1	3.1
3.500	3.512	681.0	16.637	2.161	15.247	6.563	6.2	3.1
3.550	3.562	696.7	16.606	2.192	15.248	6.531	6.3	3.1
3.600	3.612	712.4	16.575	2.222	15.242	6.502	6.3	3.2
3.650	3.662	728.2	16.546	2.253	15.236	6.476	6.4	3.2
3.700	3.712	744.0	16.518	2.283	15.229	6.452	6.5	3.2
3.750	3.762	760.0	16.491	2.313	15.221	6.431	6.5	3.2
3.800	3.812	776.0	16.464	2.343	15.214	6.411	6.6	3.2
3.850	3.862	792.1	16.439	2.373	15.208	6.390	6.7	3.2
3.900	3.912	808.2	16.414	2.403	15.202	6.371	6.8	3.2
3.950	3.962	824.4	16.390	2.433	15.193	6.355	6.8	3.3
4.000	4.012	840.7	16.367	2.463	15.185	6.340	6.9	3.3
4.050	4.062	857.1	16.344	2.493	15.177	6.327	7.0	3.3
4.100	4.112	873.6	16.322	2.523	15.170	6.314	7.0	3.3
4.150	4.162	890.1	16.301	2.553	15.163	6.303	7.1	3.3
4.200	4.212	906.7	16.280	2.582	15.155	6.294	7.2	3.3
4.250	4.262	923.3	16.259	2.612	15.147	6.286	7.2	3.3
4.300	4.312	940.1	16.239	2.642	15.140	6.278	7.3	3.4
4.350	4.362	956.9	16.220	2.671	15.135	6.270	7.4	3.4
4.400	4.412	973.8	16.201	2.701	15.130	6.264	7.4	3.4
4.450	4.462	990.7	16.183	2.730	15.124	6.259	7.5	3.4
4.500	4.512	1007.7	16.165	2.760	15.118	6.255	7.6	3.4

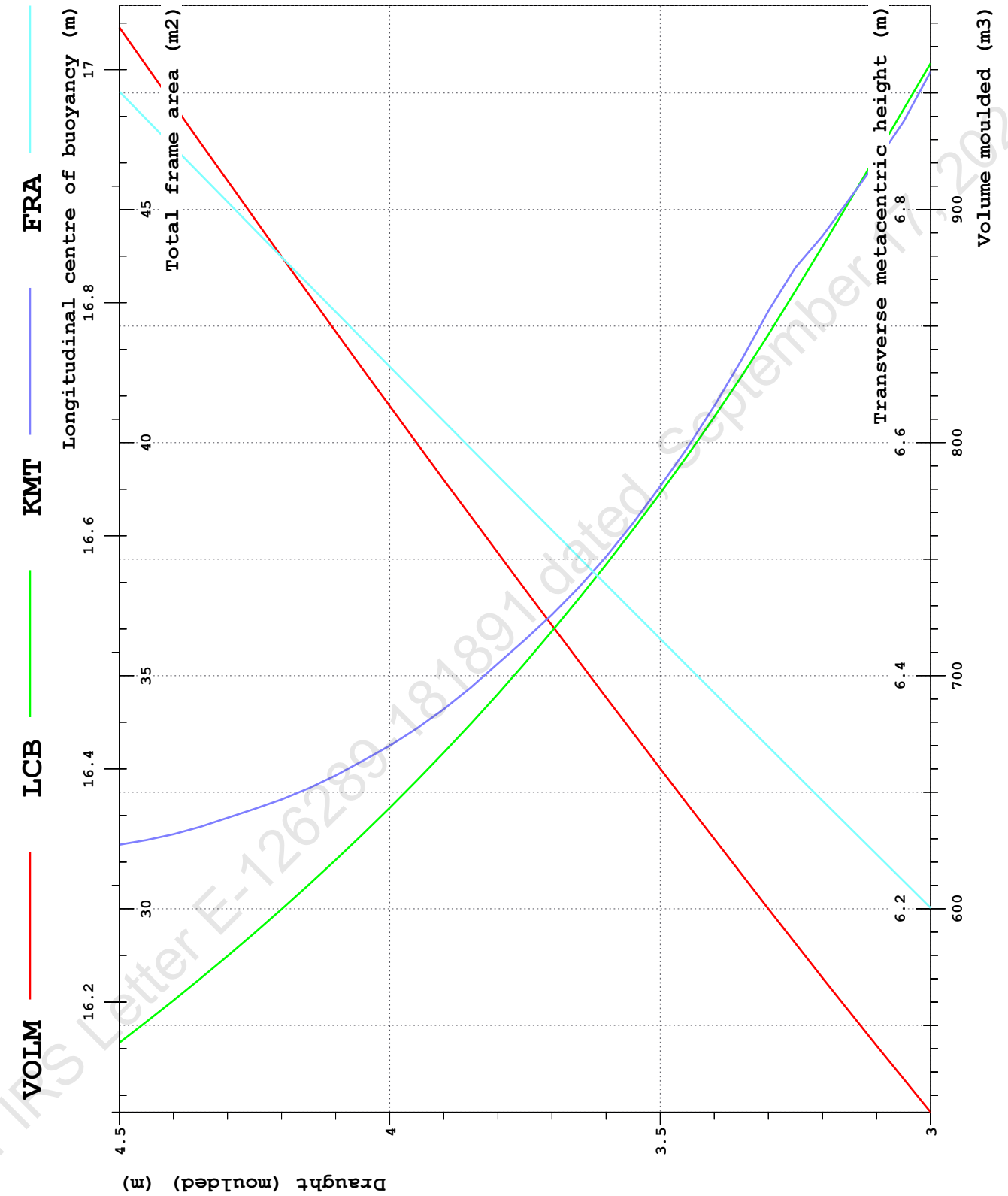

Trim: -0.6 m

T m	TK m	DISP t	LCB m	VCB m	LCF m	KMT m	MCT tm/cm	TPC t/cm
3.000	3.012	534.0	16.389	1.864	15.004	7.045	5.5	3.0
3.050	3.062	548.9	16.351	1.896	14.996	6.988	5.6	3.0
3.100	3.112	563.8	16.316	1.928	15.002	6.930	5.7	3.0
3.150	3.162	578.9	16.281	1.960	15.001	6.877	5.7	3.0
3.200	3.212	594.1	16.249	1.991	14.999	6.827	5.8	3.0
3.250	3.262	609.3	16.218	2.023	14.996	6.780	5.9	3.1
3.300	3.312	624.6	16.188	2.054	14.992	6.737	5.9	3.1
3.350	3.362	640.0	16.159	2.085	14.990	6.696	6.0	3.1
3.400	3.412	655.5	16.131	2.116	14.987	6.659	6.1	3.1
3.450	3.462	671.0	16.105	2.147	14.984	6.625	6.2	3.1
3.500	3.512	686.7	16.079	2.177	14.982	6.594	6.2	3.1
3.550	3.562	702.4	16.055	2.208	14.977	6.565	6.3	3.1
3.600	3.612	718.1	16.031	2.238	14.969	6.535	6.4	3.2
3.650	3.662	734.0	16.009	2.269	14.962	6.506	6.5	3.2
3.700	3.712	749.9	15.987	2.299	14.956	6.480	6.5	3.2
3.750	3.762	766.0	15.965	2.329	14.949	6.457	6.6	3.2
3.800	3.812	782.0	15.945	2.360	14.943	6.436	6.7	3.2
3.850	3.862	798.2	15.924	2.390	14.944	6.416	6.7	3.2
3.900	3.912	814.4	15.905	2.420	14.939	6.398	6.8	3.3
3.950	3.962	830.7	15.886	2.450	14.934	6.381	6.9	3.3
4.000	4.012	847.1	15.867	2.480	14.927	6.366	7.0	3.3
4.050	4.062	863.5	15.849	2.509	14.921	6.352	7.0	3.3
4.100	4.112	880.1	15.832	2.539	14.917	6.338	7.1	3.3
4.150	4.162	896.6	15.815	2.569	14.912	6.325	7.2	3.3
4.200	4.212	913.3	15.798	2.599	14.907	6.314	7.2	3.3
4.250	4.262	930.0	15.782	2.628	14.901	6.304	7.3	3.4
4.300	4.312	946.8	15.766	2.658	14.896	6.295	7.4	3.4
4.350	4.362	963.7	15.751	2.688	14.892	6.287	7.4	3.4
4.400	4.412	980.6	15.736	2.717	14.888	6.279	7.5	3.4
4.450	4.462	997.6	15.721	2.747	14.892	6.272	7.6	3.4
4.500	4.512	1014.7	15.707	2.776	14.902	6.265	7.6	3.4

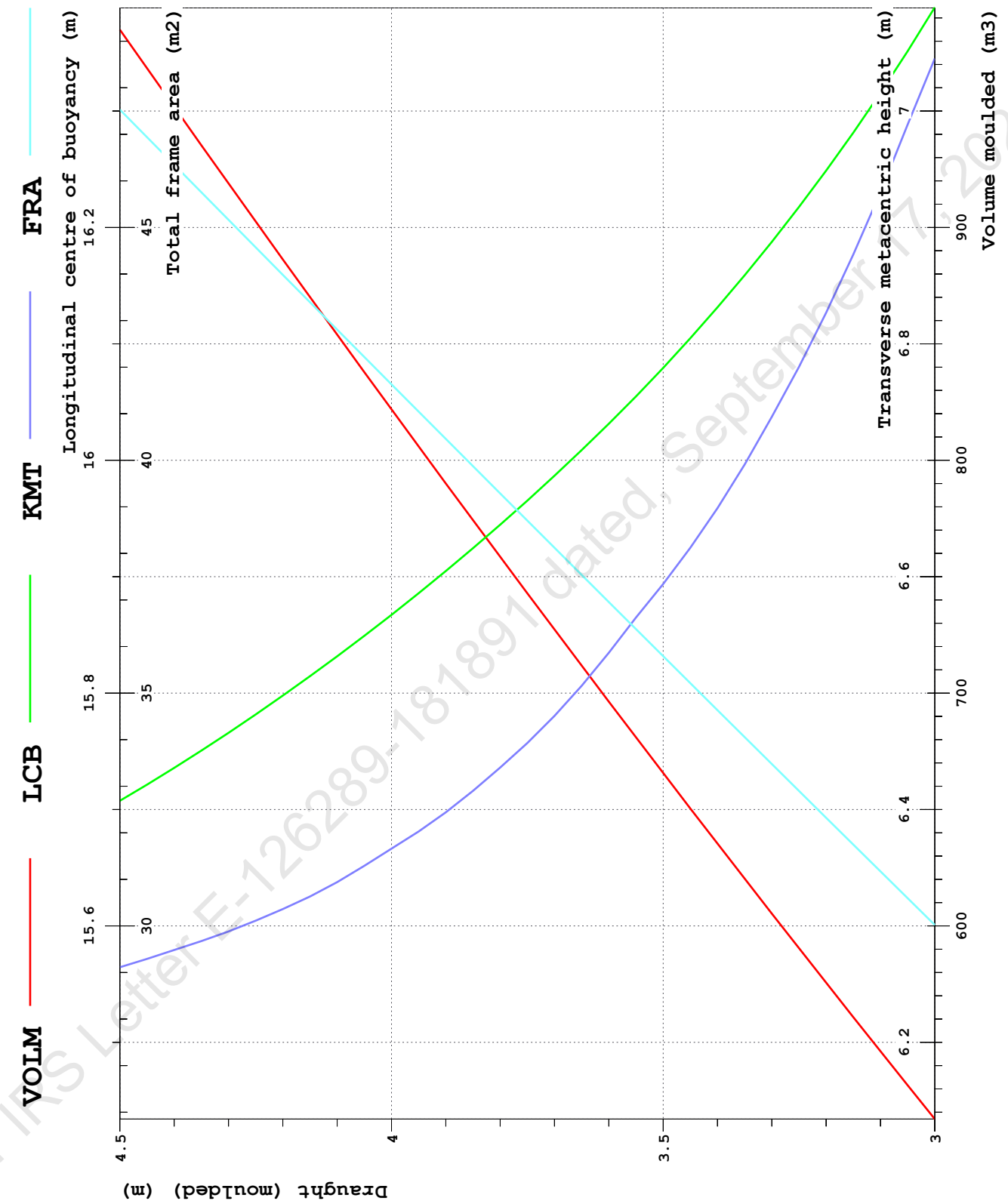

Trim: 0.6 m

T m	TK m	DISP t	LCB m	VCB m	LCF m	KMT m	MCT tm/cm	TPC t/cm
3.000	3.012	528.5	17.572	1.852	16.168	6.788	4.8	2.8
3.050	3.062	542.6	17.535	1.882	16.099	6.758	4.9	2.9
3.100	3.112	557.0	17.498	1.913	16.021	6.734	5.1	2.9
3.150	3.162	571.5	17.460	1.944	15.941	6.716	5.2	2.9
3.200	3.212	586.2	17.421	1.975	15.884	6.676	5.3	2.9
3.250	3.262	601.0	17.383	2.005	15.829	6.643	5.5	3.0
3.300	3.312	615.9	17.345	2.036	15.760	6.616	5.6	3.0
3.350	3.362	631.0	17.306	2.067	15.695	6.595	5.7	3.0
3.400	3.412	646.2	17.267	2.097	15.640	6.574	5.9	3.1
3.450	3.462	661.5	17.229	2.128	15.592	6.551	6.0	3.1
3.500	3.512	677.0	17.191	2.158	15.546	6.532	6.1	3.1
3.550	3.562	692.5	17.153	2.189	15.515	6.510	6.2	3.1
3.600	3.612	708.2	17.117	2.219	15.501	6.483	6.3	3.1
3.650	3.662	723.9	17.081	2.250	15.495	6.457	6.4	3.2
3.700	3.712	739.7	17.047	2.280	15.486	6.433	6.4	3.2
3.750	3.762	755.6	17.014	2.310	15.478	6.410	6.5	3.2
3.800	3.812	771.5	16.982	2.340	15.470	6.389	6.6	3.2
3.850	3.862	787.5	16.952	2.370	15.461	6.370	6.6	3.2
3.900	3.912	803.6	16.922	2.400	15.453	6.353	6.7	3.2
3.950	3.962	819.8	16.893	2.430	15.444	6.338	6.8	3.2
4.000	4.012	836.0	16.864	2.459	15.435	6.326	6.8	3.3
4.050	4.062	852.4	16.837	2.489	15.429	6.312	6.9	3.3
4.100	4.112	868.7	16.810	2.519	15.423	6.299	7.0	3.3
4.150	4.162	885.2	16.784	2.548	15.416	6.288	7.0	3.3
4.200	4.212	901.7	16.759	2.578	15.408	6.279	7.1	3.3
4.250	4.262	918.3	16.735	2.608	15.399	6.271	7.2	3.3
4.300	4.312	935.0	16.711	2.637	15.391	6.265	7.2	3.3
4.350	4.362	951.7	16.688	2.667	15.384	6.258	7.3	3.4
4.400	4.412	968.5	16.665	2.696	15.378	6.253	7.4	3.4
4.450	4.462	985.4	16.643	2.725	15.370	6.250	7.4	3.4
4.500	4.512	1002.3	16.621	2.755	15.363	6.247	7.5	3.4

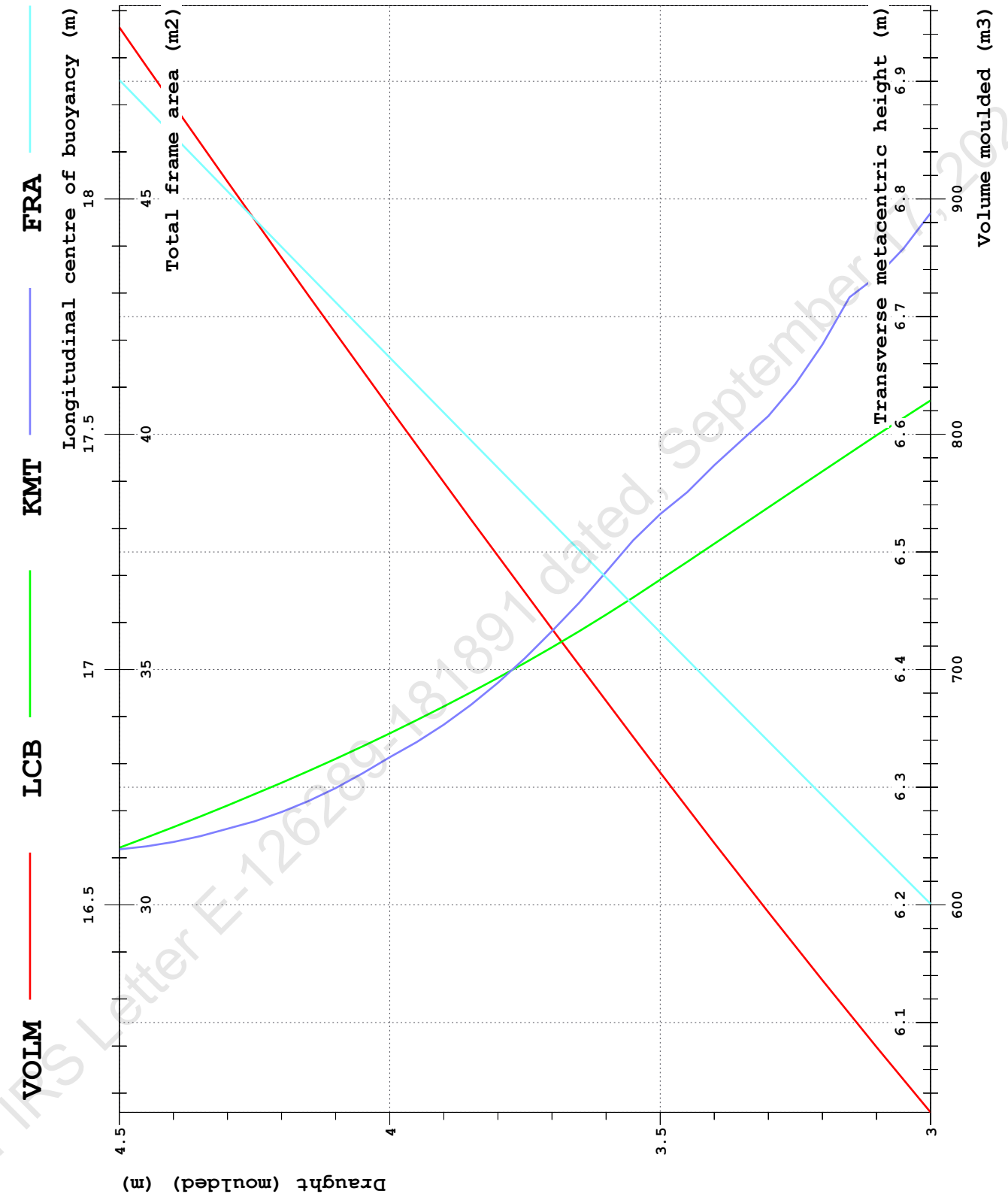

10 CROSS CURVES

Trim: 0 m

draught	KN (For Diff Heel Angles)							
	0.0	5.0	10.0	20.0	30.0	40.0	50.0	60.0
3.000	-0.008	0.595	1.193	2.340	3.296	3.940	4.337	4.498
3.050	-0.008	0.592	1.186	2.332	3.288	3.930	4.323	4.482
3.100	-0.007	0.589	1.180	2.324	3.280	3.920	4.308	4.466
3.150	-0.007	0.586	1.174	2.316	3.271	3.909	4.292	4.449
3.200	-0.007	0.583	1.169	2.308	3.261	3.897	4.276	4.432
3.250	-0.007	0.580	1.163	2.301	3.250	3.884	4.260	4.415
3.300	-0.007	0.578	1.158	2.294	3.238	3.871	4.242	4.397
3.350	-0.006	0.575	1.153	2.287	3.225	3.856	4.225	4.379
3.400	-0.006	0.572	1.148	2.279	3.211	3.841	4.207	4.361
3.450	-0.006	0.570	1.144	2.272	3.197	3.825	4.188	4.343
3.500	-0.006	0.567	1.139	2.265	3.182	3.808	4.169	4.325
3.550	-0.006	0.565	1.135	2.256	3.167	3.791	4.150	4.307
3.600	-0.006	0.562	1.131	2.248	3.151	3.773	4.130	4.288
3.650	-0.006	0.560	1.127	2.239	3.134	3.754	4.110	4.269
3.700	-0.006	0.558	1.123	2.229	3.116	3.735	4.090	4.251
3.750	-0.005	0.556	1.120	2.219	3.099	3.715	4.069	4.232
3.800	-0.005	0.554	1.116	2.208	3.080	3.694	4.048	4.213
3.850	-0.005	0.553	1.113	2.197	3.062	3.673	4.027	4.194
3.900	-0.005	0.551	1.110	2.186	3.043	3.651	4.006	4.175
3.950	-0.005	0.550	1.107	2.174	3.024	3.628	3.984	4.156
4.000	-0.005	0.549	1.104	2.161	3.005	3.605	3.962	4.136
4.050	-0.005	0.548	1.102	2.149	2.984	3.581	3.939	4.117
4.100	-0.005	0.547	1.099	2.136	2.964	3.557	3.917	4.097
4.150	-0.005	0.546	1.097	2.122	2.943	3.532	3.894	4.078
4.200	-0.005	0.545	1.095	2.108	2.921	3.507	3.871	4.058
4.250	-0.004	0.544	1.093	2.094	2.899	3.481	3.847	4.038
4.300	-0.004	0.544	1.091	2.079	2.877	3.455	3.823	4.018
4.350	-0.004	0.543	1.089	2.064	2.854	3.429	3.799	3.998
4.400	-0.004	0.543	1.087	2.049	2.830	3.401	3.774	3.977
4.450	-0.004	0.542	1.085	2.034	2.806	3.374	3.749	3.957
4.500	-0.004	0.542	1.083	2.018	2.782	3.346	3.724	3.936

Trim: 0 m

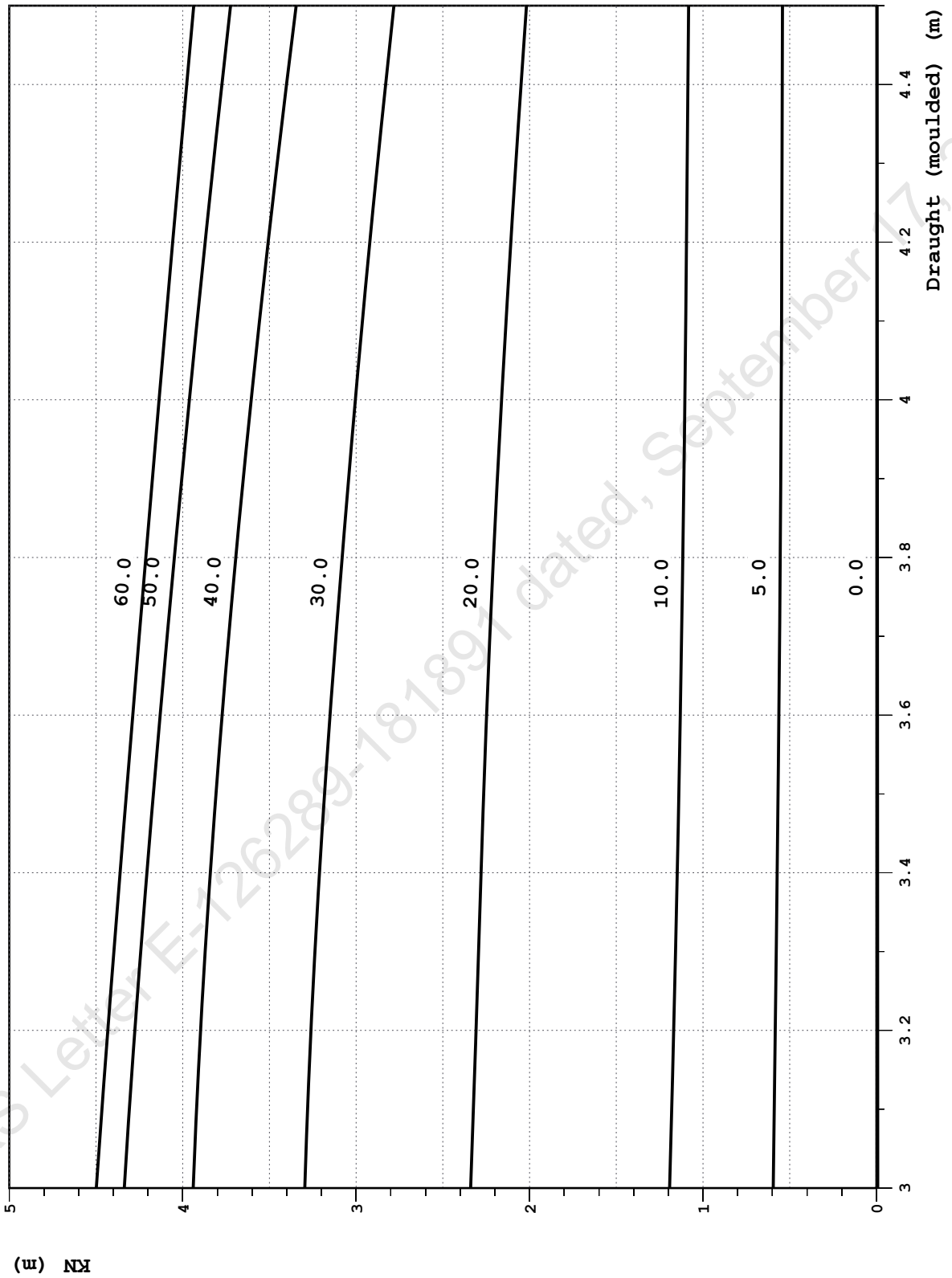

Trim: -0.6 m

draught	KN (For Diff Heel Angles)							
	0.0	5.0	10.0	20.0	30.0	40.0	50.0	60.0
3.000	-0.008	0.604	1.209	2.369	3.319	3.941	4.330	4.489
3.050	-0.007	0.600	1.202	2.359	3.308	3.928	4.314	4.471
3.100	-0.007	0.596	1.195	2.350	3.297	3.915	4.297	4.453
3.150	-0.007	0.593	1.188	2.341	3.284	3.902	4.279	4.434
3.200	-0.007	0.589	1.181	2.332	3.271	3.887	4.262	4.416
3.250	-0.007	0.585	1.175	2.324	3.257	3.872	4.243	4.397
3.300	-0.007	0.582	1.169	2.315	3.242	3.856	4.224	4.378
3.350	-0.006	0.579	1.163	2.307	3.226	3.839	4.205	4.359
3.400	-0.006	0.575	1.158	2.298	3.210	3.822	4.185	4.340
3.450	-0.006	0.572	1.152	2.289	3.193	3.804	4.165	4.321
3.500	-0.006	0.570	1.147	2.279	3.175	3.785	4.144	4.302
3.550	-0.006	0.567	1.142	2.269	3.157	3.766	4.124	4.282
3.600	-0.006	0.565	1.137	2.258	3.138	3.746	4.102	4.263
3.650	-0.006	0.563	1.133	2.246	3.118	3.726	4.081	4.243
3.700	-0.005	0.560	1.129	2.234	3.098	3.704	4.059	4.223
3.750	-0.005	0.559	1.125	2.221	3.077	3.683	4.037	4.203
3.800	-0.005	0.557	1.121	2.208	3.056	3.660	4.015	4.183
3.850	-0.005	0.555	1.117	2.194	3.035	3.637	3.992	4.163
3.900	-0.005	0.554	1.114	2.180	3.013	3.614	3.969	4.143
3.950	-0.005	0.552	1.111	2.166	2.991	3.590	3.946	4.123
4.000	-0.005	0.551	1.108	2.151	2.969	3.565	3.923	4.102
4.050	-0.005	0.550	1.105	2.135	2.947	3.539	3.899	4.081
4.100	-0.005	0.549	1.102	2.119	2.924	3.514	3.875	4.060
4.150	-0.005	0.548	1.099	2.103	2.901	3.487	3.851	4.040
4.200	-0.004	0.547	1.097	2.087	2.877	3.460	3.826	4.018
4.250	-0.004	0.546	1.095	2.070	2.853	3.433	3.801	3.997
4.300	-0.004	0.545	1.092	2.053	2.829	3.405	3.776	3.976
4.350	-0.004	0.544	1.090	2.035	2.804	3.377	3.750	3.955
4.400	-0.004	0.544	1.088	2.017	2.779	3.348	3.724	3.933
4.450	-0.004	0.543	1.084	1.999	2.753	3.319	3.698	3.911
4.500	-0.004	0.542	1.080	1.981	2.727	3.289	3.671	3.889

Trim: -0.6 m

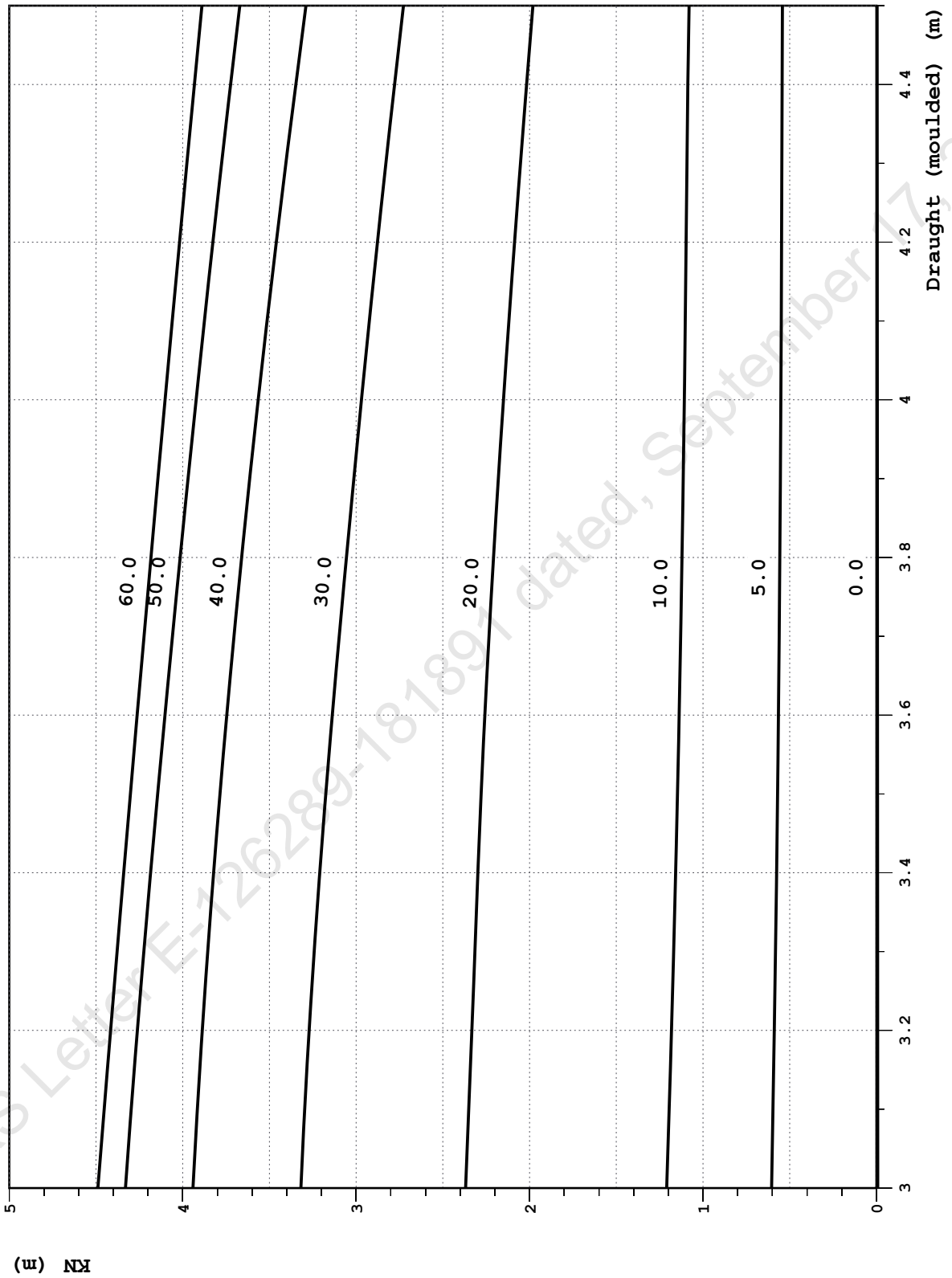

Trim: 0.6 m

draught	KN (For Diff Heel Angles)							
	0.0	5.0	10.0	20.0	30.0	40.0	50.0	60.0
3.000	-0.008	0.585	1.174	2.310	3.269	3.931	4.333	4.497
3.050	-0.008	0.582	1.168	2.303	3.264	3.924	4.320	4.482
3.100	-0.007	0.579	1.163	2.296	3.257	3.916	4.307	4.467
3.150	-0.007	0.577	1.158	2.290	3.250	3.907	4.294	4.452
3.200	-0.007	0.575	1.153	2.283	3.243	3.897	4.280	4.437
3.250	-0.007	0.572	1.149	2.277	3.234	3.886	4.265	4.421
3.300	-0.007	0.570	1.145	2.271	3.225	3.874	4.250	4.406
3.350	-0.006	0.568	1.141	2.265	3.215	3.862	4.234	4.390
3.400	-0.006	0.567	1.137	2.259	3.204	3.849	4.217	4.373
3.450	-0.006	0.565	1.133	2.252	3.192	3.835	4.200	4.357
3.500	-0.006	0.563	1.129	2.246	3.180	3.820	4.183	4.340
3.550	-0.006	0.561	1.126	2.239	3.167	3.804	4.165	4.323
3.600	-0.006	0.559	1.123	2.232	3.154	3.788	4.147	4.305
3.650	-0.006	0.558	1.119	2.225	3.139	3.771	4.128	4.288
3.700	-0.006	0.556	1.116	2.217	3.125	3.753	4.109	4.270
3.750	-0.005	0.554	1.114	2.209	3.110	3.734	4.090	4.253
3.800	-0.005	0.553	1.111	2.201	3.094	3.715	4.071	4.235
3.850	-0.005	0.551	1.108	2.192	3.079	3.695	4.051	4.217
3.900	-0.005	0.550	1.106	2.183	3.062	3.675	4.031	4.199
3.950	-0.005	0.548	1.103	2.173	3.045	3.654	4.010	4.180
4.000	-0.005	0.547	1.101	2.163	3.028	3.632	3.989	4.162
4.050	-0.005	0.546	1.099	2.153	3.010	3.610	3.968	4.143
4.100	-0.005	0.545	1.097	2.142	2.991	3.587	3.947	4.125
4.150	-0.005	0.545	1.095	2.131	2.972	3.564	3.925	4.106
4.200	-0.005	0.544	1.093	2.120	2.952	3.540	3.903	4.087
4.250	-0.004	0.543	1.091	2.108	2.932	3.516	3.881	4.069
4.300	-0.004	0.543	1.089	2.096	2.911	3.491	3.858	4.050
4.350	-0.004	0.542	1.088	2.083	2.890	3.466	3.835	4.031
4.400	-0.004	0.542	1.086	2.070	2.868	3.440	3.812	4.011
4.450	-0.004	0.541	1.085	2.057	2.846	3.414	3.788	3.992
4.500	-0.004	0.541	1.083	2.044	2.823	3.388	3.764	3.973

Trim: 0.6 m

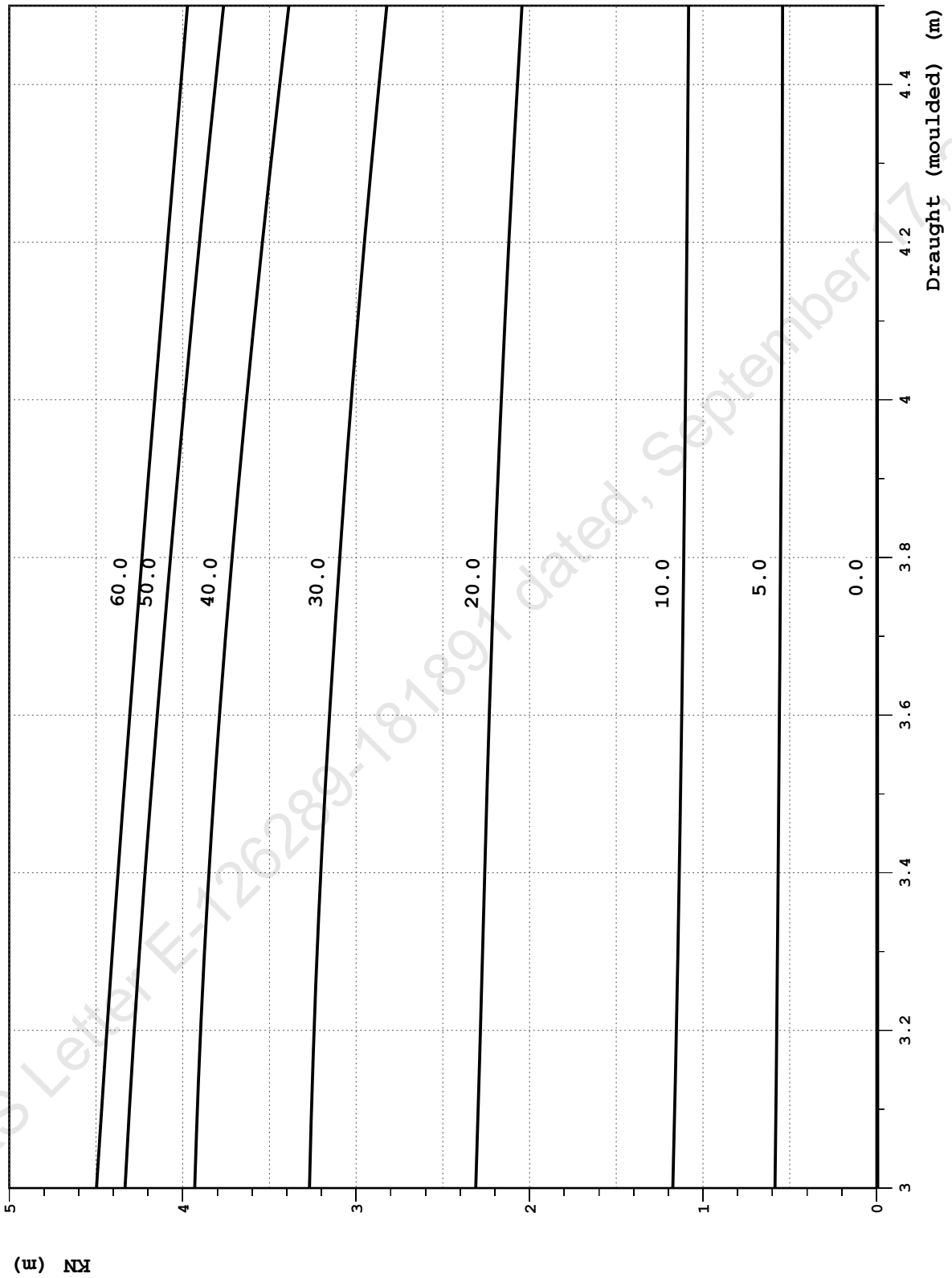

11. LOADING CONDITIONS

LOADING CONDITIONS SUMMARY TABLE

LOADING CONDITION	T m	TR m	HEEL deg	GM m	DISP t	KG m
LIGHTSHIP - Not sailing condition	3.526	-0.682	0.4	1.776	695.8	4.597
DRY DOCKING - Not sailing condition	3.705	-0.068	0.1	1.880	746.3	4.378
LC01 - DEPARTURE (100% CONSUMABLES)	4.192	-0.145	0.5	2.080	905.5	4.059
LC02 - ARRIVAL (10% CONSUMABLES)	3.691	-0.424	0.1	1.886	745.1	4.395
LC03 - LC01+CRANE LOAD(3T Load)	4.200	-0.172	0.5	2.061	908.5	4.078
LC04 - LC02+CRANE LOAD(3T Load)	3.699	-0.454	0.1	1.861	748.1	4.417

Refer IRS Letter E-126289-181897 dated, September 17, 2021

LIGHTSHIP - Not sailing condition

Floating Position - Intact condition

Draught at AP (moulded)	3.867 m
Draught at FP (moulded)	3.185 m
Mean Draught (moulded)	3.526 m
Trim (+ by Bow)	-0.682 m
Heel (+ PS)	0.4 deg
KM above moulded BL	6.583 m
KG above moulded BL	4.597 m
GM0 (solid)	1.986 m
Free Surface Correction	0.210 m
GM (liquid)	1.776 m
Density of Water	1.025 t/m ³

LCB	:	15.991 m Fwd of AP
LCF	:	14.940 m Fwd of AP
MCT	:	6.286 tm/cm
TPC	:	3.143 t/cm

LOAD SUMMARY TABLE

NAME	LOAD	MASS t	LCG m	TCG m	VCG m
Oil Spill Dispersant	DISPERSANT	0.0	0.000	0.000	0.000
Diesel Oil	DO	0.0	0.000	0.000	0.000
Fire fighting Foam	FOAM	0.0	0.000	0.000	0.000
Fresh Water	FW	0.0	0.000	0.000	0.000
Grey Water	GWT	0.0	0.000	0.000	0.000
Lubricating Oil	LO	0.0	0.000	0.000	0.000
Sludge	SLU	0.0	0.000	0.000	0.000
Deadweight		0.0	0.000	0.000	0.000
Lightweight		695.8	16.043	0.006	4.597
Deadweight		0.0	0.000	0.000	0.000
Total weight		695.8	16.043	0.006	4.597

LOADING COMPONENTS

Diesel Oil (Density 0.860 t/m3)

NAME	PURP	FILL %	MASS t	VOL m3	LCG m	TCG m	VCG m	FRSM tm
R.FODAYTK.P	DO	0.0	0.0	0.0	8.811	4.540	3.752	4.08
R.FODAYTK.S	DO	0.0	0.0	0.0	8.811	-4.540	3.752	4.08
R.FOTK.1S	DO	0.0	0.0	0.0	23.089	-3.686	2.307	0.00
R.FOTK.1P	DO	0.0	0.0	0.0	23.089	3.686	2.307	0.00
R.FOTK.2P	DO	0.0	0.0	0.0	14.194	1.037	1.041	0.00
R.FOTK.2S	DO	0.0	0.0	0.0	14.194	-1.037	1.041	0.00
R.FOTK.3P	DO	0.0	0.0	0.0	17.384	4.764	1.434	0.00
R.FOTK.3S	DO	0.0	0.0	0.0	17.384	-4.764	1.434	0.00
R.FOTK.4C	DO	0.0	0.0	0.0	8.705	0.000	1.932	76.61
TOTAL			0.0	0.0				84.76

Fresh Water (Density 1.0 t/m3)

NAME	PURP	FILL %	MASS t	VOL m3	LCG m	TCG m	VCG m	FRSM tm
R.FWTK.P	FW	0.0	0.0	0.0	27.551	1.914	2.570	16.56
R.FWTK.S	FW	0.0	0.0	0.0	27.632	-1.659	2.506	19.88
TOTAL			0.0	0.0				36.44

Lub Oil (Density 0.860 t/m3)

NAME	PURP	FILL %	MASS t	VOL m3	LCG m	TCG m	VCG m	FRSM tm
R.LOTK.P	LO	0.0	0.0	0.0	11.001	5.423	4.122	0.06
R.LOTK.S	LO	0.0	0.0	0.0	11.001	-5.423	4.122	0.06
TOTAL			0.0	0.0				0.13

FOAM (Density 1.0 t/m3)

NAME	PURP	FILL %	MASS t	VOL m3	LCG m	TCG m	VCG m	FRSM tm
R.FOAMTK	FOAM	0.0	0.0	0.0	22.738	0.000	1.044	1.63
TOTAL			0.0	0.0				1.63

DISPERSANT (Density 1.0 t/m3)

NAME	PURP	FILL %	MASS t	VOL m3	LCG m	TCG m	VCG m	FRSM tm
R.DISPERSANTTK	DISPERSANT	0.0	0.0	0.0	18.749	0.000	0.752	9.74
TOTAL			0.0	0.0				9.74

Refer IRS Letter E-126289-181891 dated, September 17, 2021

INTACT STABILITY CHECK PLOT

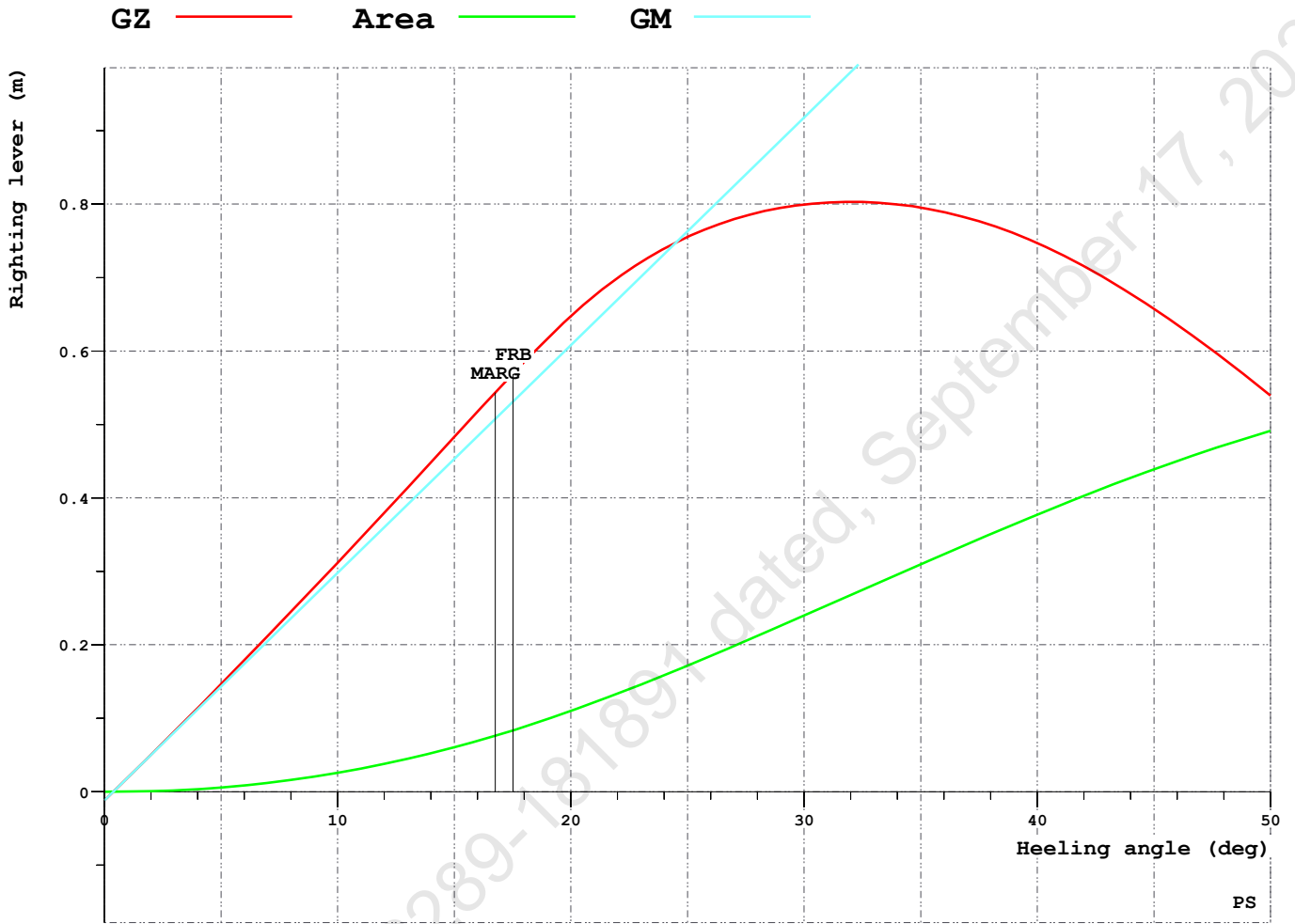

IMO WEATHER CRITERIA

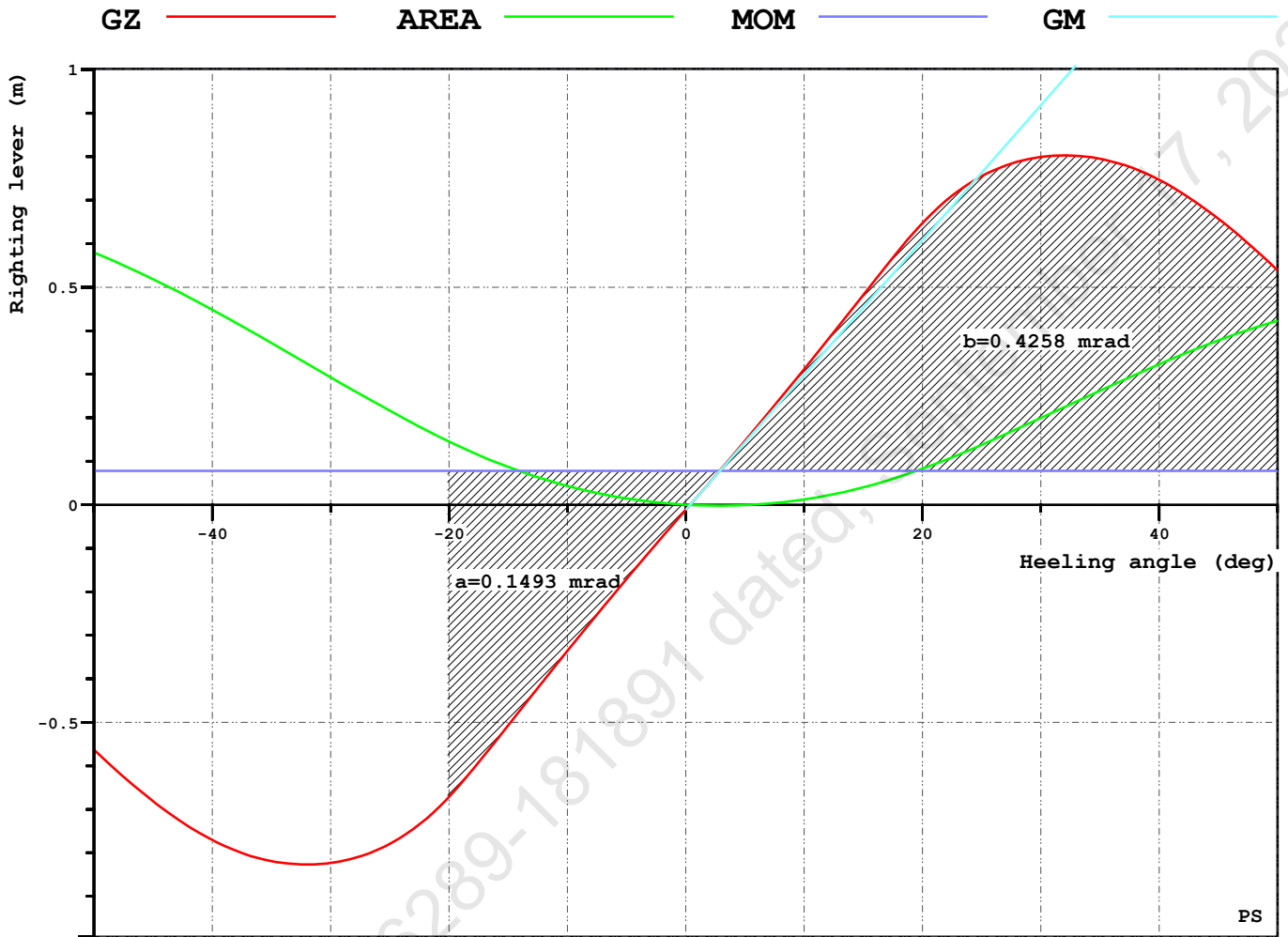

INTACT STABILITY CRITERIA

RCR	TEXT	REQ	ATTN UNIT	STAT
AREA30	Area under GZ curve up to 30 deg.	0.055	0.240 mrad	OK
AREA40	Area under GZ curve up to 40 deg.	0.090	0.377 mrad	OK
AREA3040	Area under GZ curve btw. 30-40 deg.	0.030	0.138 mrad	OK
GZ0.2	Max GZ > 0.2	0.200	0.803 m	OK
MAXGZ25	Max. GZ at an angle > 25 deg.	25.000	32.016 deg	OK
GM0.15	GM > 0.15 m	0.150	1.776 m	OK
V.IMOWEATHER	IMO weather criterion	1.000	2.851	OK
IMO.WIND_HEEL	Wind Heel <16 or <=80% of dk imm.	14.014	2.050 deg	OK
2020IS-B2.9.7.1.2	Eq. angle less than 10 deg. or dk. imm.	17.518	2.457 deg	OK
2020IS-B2.9.7.1.1	Resid. righting area > 0.08 mrad	0.080	0.235 mrad	OK

Refer IRS Letter E-126289-181897 dated, September 17, 2021

GZ CURVE DATA

HEEL deg	T m	TR m	GZ m	AREA mrad
0.0	3.526	-0.682	-0.012	0.000
0.4	3.526	-0.682	0.000	0.000
5.0	3.507	-0.672	0.146	0.006
10.0	3.448	-0.641	0.312	0.026
15.0	3.348	-0.579	0.483	0.060
20.0	3.208	-0.497	0.648	0.110
30.0	2.853	-0.461	0.800	0.240
40.0	2.383	-0.654	0.747	0.377
50.0	1.842	-0.917	0.539	0.491

RELEVANT OPENINGS

NAME	TEXT	WT	X m	Y m	Z m	IMMA deg	IMMR m
ER_V_P	ER_INLET_P	UNPROTECTED	13.373	2.300	6.300	-	2.699
ER_V_S	ER_INLET_S	UNPROTECTED	13.373	-2.300	6.300	-	2.730
ER_O_P	ER_OUT_P	UNPROTECTED	14.000	1.500	8.400	-	4.818
ER_O_S	ER_OUT_S	UNPROTECTED	14.000	-1.500	8.400	-	4.838

DRY DOCKING - Not sailing condition

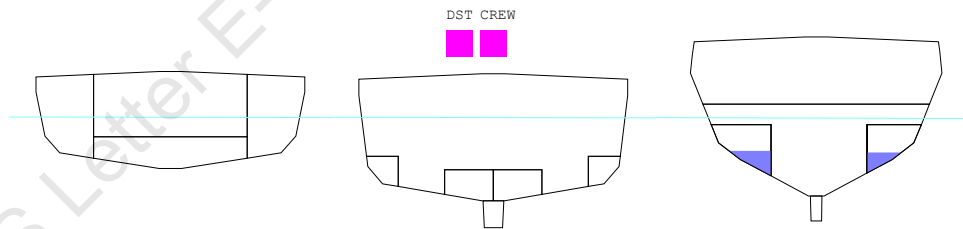
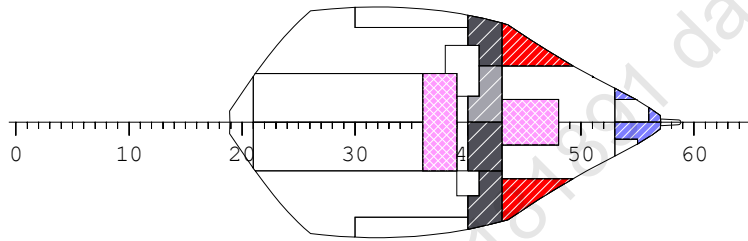
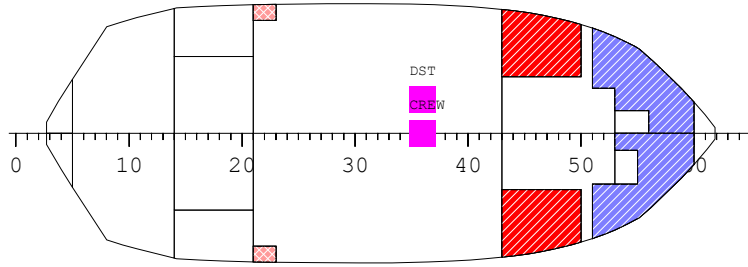
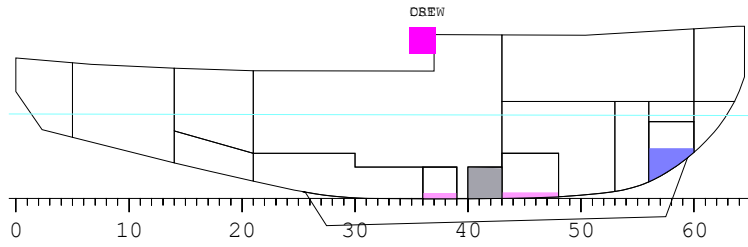

Diesel Oil	Fresh Water	Lubricating Oil
Sludge	Oil Spill Dispersant	Fire fighting Foam
Grey Water		

DRY DOCKING - Not sailing condition

Floating Position - Intact condition

Draught at AP (moulded)	3.739 m
Draught at FP (moulded)	3.671 m
Mean Draught (moulded)	3.705 m
Trim (+ by Bow)	-0.068 m
Heel (+ PS)	0.1 deg
KM above moulded BL	6.453 m
KG above moulded BL	4.378 m
GM0 (solid)	2.076 m
Free Surface Correction	0.196 m
GM (liquid)	1.880 m
Density of Water	1.025 t/m3

LCB : 16.455 m Fwd of AP
LCF : 15.201 m Fwd of AP

MCT : 6.484 tm/cm
TPC : 3.183 t/cm

LOAD SUMMARY TABLE

NAME	LOAD	MASS t	LCG m	TCG m	VCG m
Crew	CREW	1.0	18.000	0.000	7.000
Oil Spill Dispersant	DISPERSANT	0.8	18.743	0.000	0.141
Diesel Oil	DO	7.9	22.871	0.000	1.355
Deck Store	DST	0.2	18.000	1.500	7.000
Fire fighting Foam	FOAM	0.9	22.635	0.000	0.175
Fresh Water	FW	9.4	27.461	0.254	1.716
Grey Water	GWT	3.5	20.842	1.034	0.741
Lubricating Oil	LO	0.4	11.003	0.000	2.781
Sludge	SLU	26.3	20.768	-0.434	1.102
Deadweight		50.5	22.203	-0.100	1.352
Lightweight		695.8	16.043	0.006	4.597
Deadweight		50.5	22.203	-0.100	1.352
Total weight		746.3	16.460	-0.001	4.378

LOADING COMPONENTS

Diesel Oil (Density 0.860 t/m3)

NAME	PURP	FILL %	MASS t	VOL m3	LCG m	TCG m	VCG m	FRSM tm
R.FODAYTK.P	DO	0.0	0.0	0.0	8.811	4.540	3.752	4.08
R.FODAYTK.S	DO	0.0	0.0	0.0	8.811	-4.540	3.752	4.08
R.FOTK.1S	DO	24.1	3.9	4.6	23.089	-3.686	2.307	0.00
R.FOTK.1P	DO	24.1	3.9	4.6	23.089	3.686	2.307	0.00
R.FOTK.2P	DO	0.0	0.0	0.0	14.194	1.037	1.041	0.00
R.FOTK.2S	DO	0.0	0.0	0.0	14.194	-1.037	1.041	0.00
R.FOTK.3P	DO	0.0	0.0	0.0	17.384	4.764	1.434	0.00
R.FOTK.3S	DO	0.0	0.0	0.0	17.384	-4.764	1.434	0.00
R.FOTK.4C	DO	0.0	0.0	0.0	8.705	0.000	1.932	76.61
TOTAL			7.9	9.2				84.76

Fresh Water (Density 1.0 t/m3)

NAME	PURP	FILL %	MASS t	VOL m3	LCG m	TCG m	VCG m	FRSM tm
R.FWTK.P	FW	27.8	4.7	4.7	27.551	1.914	2.570	16.56
R.FWTK.S	FW	27.4	4.7	4.7	27.632	-1.659	2.506	19.88
TOTAL			9.4	9.4				36.44

Lub Oil (Density 0.860 t/m3)

NAME	PURP	FILL %	MASS t	VOL m3	LCG m	TCG m	VCG m	FRSM tm
R.LOTK.P	LO	10.0	0.2	0.2	11.001	5.423	4.122	0.06
R.LOTK.S	LO	10.0	0.2	0.2	11.001	-5.423	4.122	0.06
TOTAL			0.4	0.5				0.13

FOAM (Density 1.0 t/m3)

NAME	PURP	FILL %	MASS t	VOL m3	LCG m	TCG m	VCG m	FRSM tm
R.FOAMTK	FOAM	10.0	0.9	0.9	22.738	0.000	1.044	1.63
TOTAL			0.9	0.9				1.63

DISPERSANT (Density 1.0 t/m3)

NAME	PURP	FILL %	MASS t	VOL m3	LCG m	TCG m	VCG m	FRSM tm
R.DISPERSANTTK	DISPERSANT	10.0	0.8	0.8	18.749	0.000	0.752	9.74
TOTAL			0.8	0.8				9.74

STORES

NAME	PURP	MASS t	LCG m	TCG m	VCG m
STORES	MASS	0.2	18.000	1.500	7.000
TOTAL		0.2	18.000	1.500	7.000

CREW

NAME	PURP	MASS t	LCG m	TCG m	VCG m
CREW	MASS	1.0	18.000	0.000	7.000
TOTAL		1.0	18.000	0.000	7.000

INTACT STABILITY CHECK PLOT

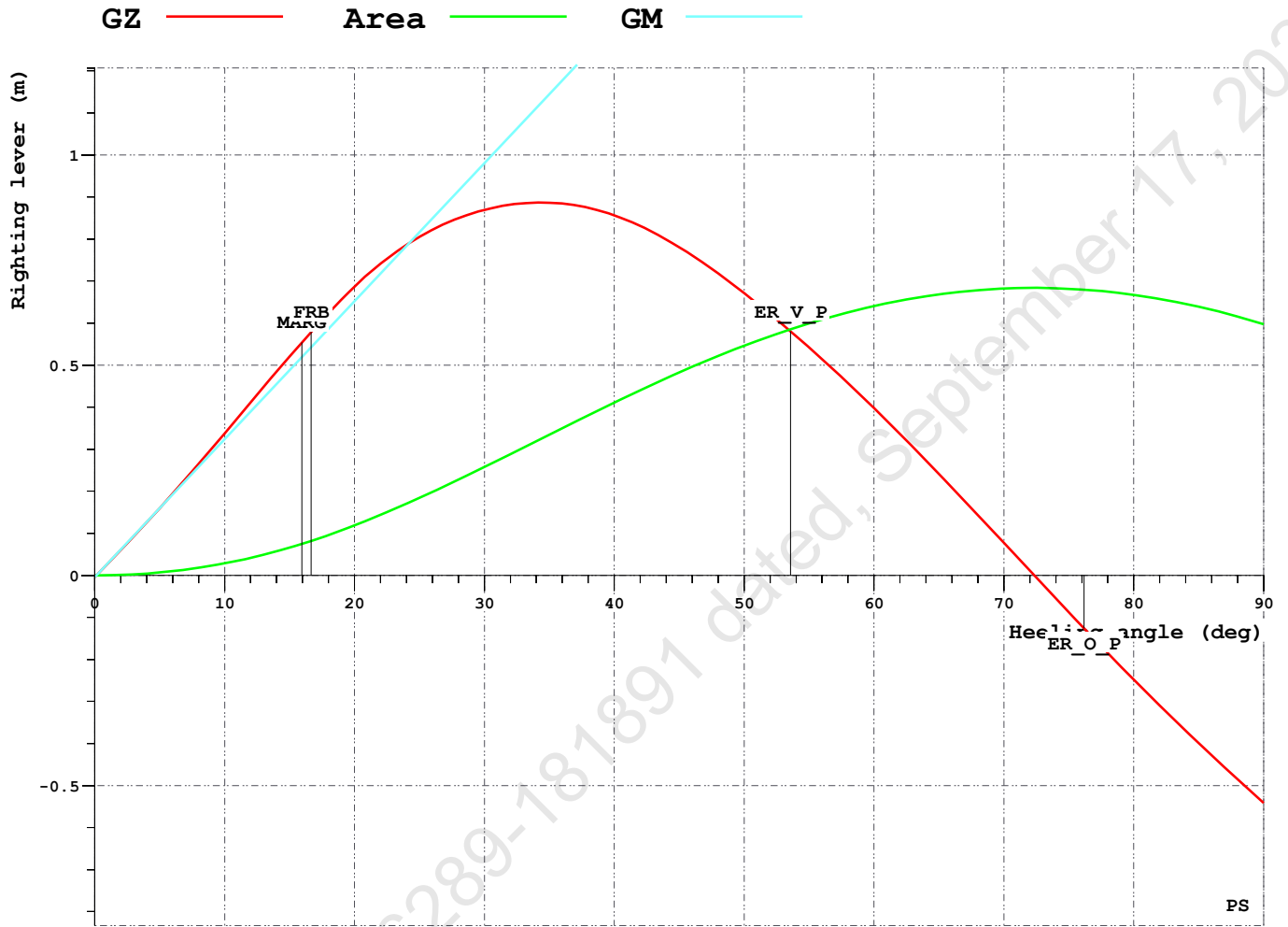

IMO WEATHER CRITERIA

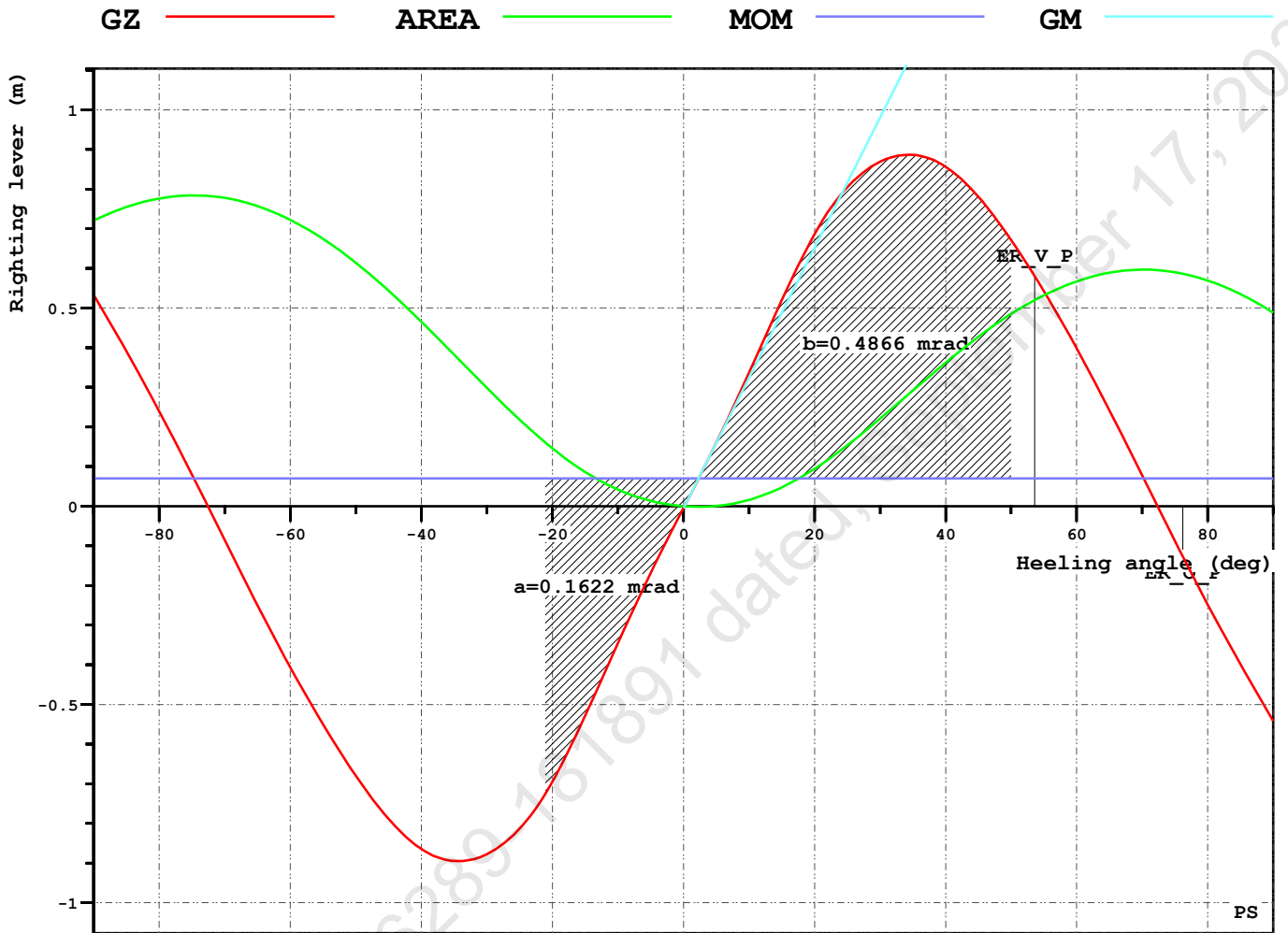

INTACT STABILITY CRITERIA

RCR	TEXT	REQ	ATTN UNIT	STAT
AREA30	Area under GZ curve up to 30 deg.	0.055	0.257 mrad	OK
AREA40	Area under GZ curve up to 40 deg.	0.090	0.411 mrad	OK
AREA3040	Area under GZ curve btw. 30-40 deg.	0.030	0.153 mrad	OK
GZ0.2	Max GZ > 0.2	0.200	0.887 m	OK
MAXGZ25	Max. GZ at an angle > 25 deg.	25.000	34.356 deg	OK
GM0.15	GM > 0.15 m	0.150	1.880 m	OK
V.IMOWEATHER	IMO weather criterion	1.000	2.999	OK
IMO.WIND_HEEL	Wind Heel <16 or <=80% of dk imm.	13.333	1.597 deg	OK

Refer IRS Letter E-126289-181897 dated, September 17, 2021

GZ CURVE DATA

HEEL deg	T m	TR m	GZ m	AREA mrad
0.0	3.705	-0.068	-0.004	0.000
0.1	3.705	-0.068	0.000	0.000
10.0	3.624	-0.033	0.337	0.028
20.0	3.381	0.095	0.687	0.119
30.0	3.032	0.113	0.869	0.257
40.0	2.580	-0.066	0.856	0.411
50.0	2.058	-0.289	0.671	0.546
60.0	1.487	-0.502	0.398	0.640
70.0	0.881	-0.703	0.077	0.682
80.0	0.269	-0.819	-0.249	0.667
90.0	-0.320	-0.917	-0.542	0.597

RELEVANT OPENINGS

NAME	TEXT	WT	X m	Y m	Z m	IMMA deg	IMMR m
ER_V_P	ER_INLET_P	UNPROTECTED	13.373	2.300	6.300	53.6	2.584
ER_V_S	ER_INLET_S	UNPROTECTED	13.373	-2.300	6.300	-	2.595
ER_O_P	ER_OUT_P	UNPROTECTED	14.000	1.500	8.400	76.2	4.687
ER_O_S	ER_OUT_S	UNPROTECTED	14.000	-1.500	8.400	-	4.694

LC01 - DEPARTURE (100% CONSUMABLES)

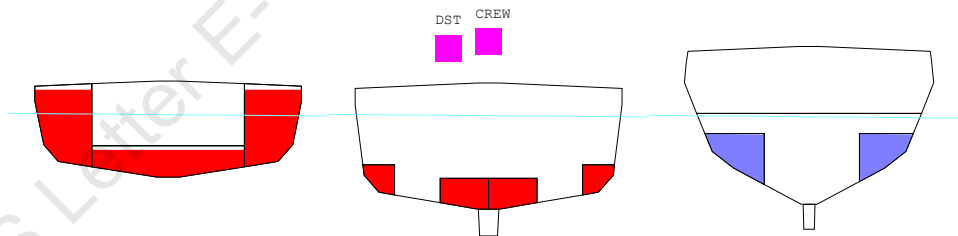
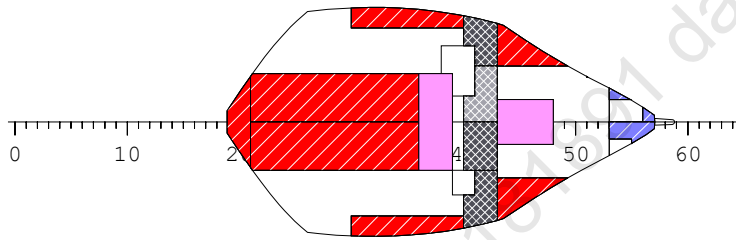
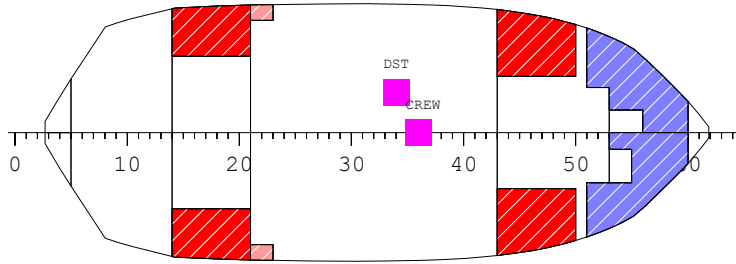
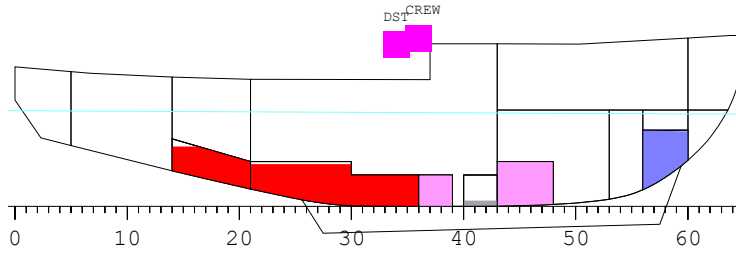

Diesel Oil	Fresh Water	Lubricating Oil
Sludge	Oil Spill Dispersant	Fire fighting Foam
Grey Water		

LC01 - DEPARTURE (100% CONSUMABLES)

Floating Position - Intact condition

Draught at AP (moulded)	4.264 m
Draught at FP (moulded)	4.119 m
Mean Draught (moulded)	4.192 m
Trim (+ by Bow)	-0.145 m
Heel (+ PS)	0.5 deg
KM above moulded BL	6.301 m
KG above moulded BL	4.059 m
GM0 (solid)	2.242 m
Free Surface Correction	0.162 m
GM (liquid)	2.080 m
Density of Water	1.025 t/m3

LCB : 16.166 m Fwd of AP
LCF : 15.097 m Fwd of AP

MCT : 7.164 tm/cm
TPC : 3.326 t/cm

LOAD SUMMARY TABLE

NAME	LOAD	MASS t	LCG m	TCG m	VCG m
Crew	CREW	1.0	18.000	0.000	7.500
Oil Spill Dispersant	DISPERSANT	8.1	18.749	0.000	0.752
Diesel Oil	DO	149.7	13.781	0.000	2.274
Deck Store	DST	2.0	17.000	1.800	7.200
Fire fighting Foam	FOAM	9.4	22.738	0.000	1.044
Fresh Water	FW	32.3	27.584	0.119	2.494
Grey Water	GWT	0.4	20.745	0.546	0.148
Lubricating Oil	LO	4.0	11.001	0.000	4.055
Sludge	SLU	2.8	20.800	-0.202	0.501
Deadweight		209.7	16.605	0.034	2.272
Lightweight		695.8	16.043	0.006	4.597
Deadweight		209.7	16.605	0.034	2.272
Total weight		905.5	16.173	0.012	4.059

LOADING COMPONENTS

Diesel Oil (Density 0.860 t/m3)

NAME	PURP	FILL %	MASS t	VOL m3	LCG m	TCG m	VCG m	FRSM tm
R.FODAYTK.P	DO	95.0	24.1	28.0	8.811	4.540	3.752	4.08
R.FODAYTK.S	DO	95.0	24.1	28.0	8.811	-4.540	3.752	4.08
R.FOTK.1S	DO	95.0	15.5	18.1	23.089	-3.686	2.307	0.00
R.FOTK.1P	DO	95.0	15.5	18.1	23.089	3.686	2.307	0.00
R.FOTK.2P	DO	95.0	18.8	21.9	14.194	1.037	1.041	0.00
R.FOTK.2S	DO	95.0	18.8	21.9	14.194	-1.037	1.041	0.00
R.FOTK.3P	DO	95.0	5.6	6.5	17.384	4.764	1.434	0.00
R.FOTK.3S	DO	95.0	5.6	6.5	17.384	-4.764	1.434	0.00
R.FOTK.4C	DO	95.0	21.7	25.3	8.705	0.000	1.932	76.61
TOTAL			149.7	174.1				84.76

Fresh Water (Density 1.0 t/m3)

NAME	PURP	FILL %	MASS t	VOL m3	LCG m	TCG m	VCG m	FRSM tm
R.FWTK.P	FW	95.0	16.1	16.1	27.551	1.914	2.570	16.56
R.FWTK.S	FW	95.0	16.3	16.3	27.632	-1.659	2.506	19.88
TOTAL			32.3	32.3				36.44

Lub Oil (Density 0.860 t/m3)

NAME	PURP	FILL %	MASS t	VOL m3	LCG m	TCG m	VCG m	FRSM tm
R.LOTK.P	LO	95.0	2.0	2.2	11.001	5.423	4.122	0.06
R.LOTK.S	LO	95.0	2.0	2.2	11.001	-5.423	4.122	0.06
TOTAL			4.0	4.4				0.13

FOAM (Density 1.0 t/m3)

NAME	PURP	FILL %	MASS t	VOL m3	LCG m	TCG m	VCG m	FRSM tm
R.FOAMTK	FOAM	100.0	9.4	9.4	22.738	0.000	1.044	1.63
TOTAL			9.4	9.4				1.63

DISPERSANT (Density 1.0 t/m3)

NAME	PURP	FILL %	MASS t	VOL m3	LCG m	TCG m	VCG m	FRSM tm
R.DISPERSANTTK	DISPERSANT	100.0	8.1	8.1	18.749	0.000	0.752	9.74
TOTAL			8.1	8.1				9.74

STORES

NAME	PURP	MASS t	LCG m	TCG m	VCG m
STORES	MASS	2.0	17.000	1.800	7.200
TOTAL		2.0	17.000	1.800	7.200

CREW

NAME	PURP	MASS t	LCG m	TCG m	VCG m
CREW	MASS	1.0	18.000	0.000	7.500
TOTAL		1.0	18.000	0.000	7.500

INTACT STABILITY CHECK PLOT

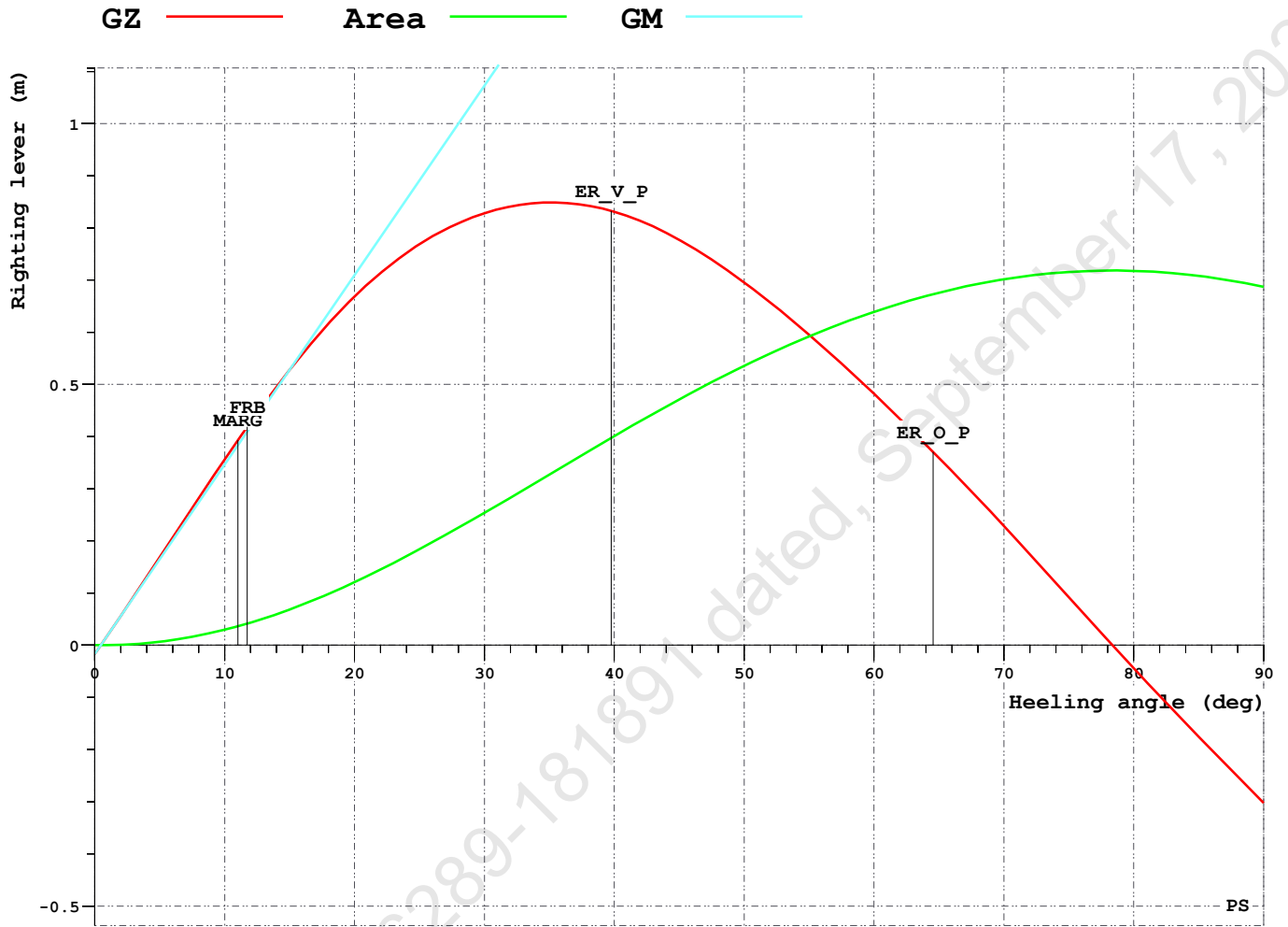

IMO WEATHER CRITERIA

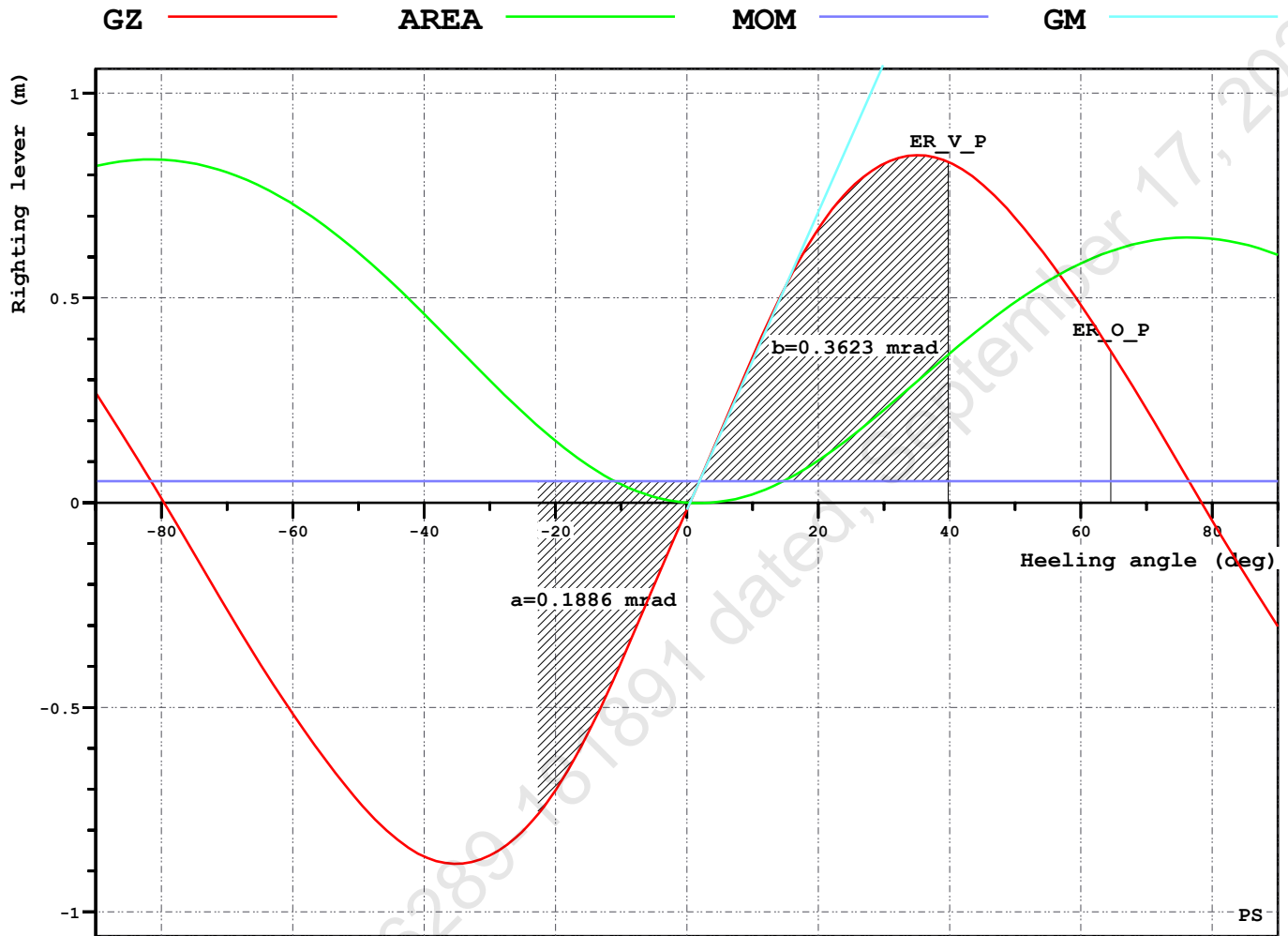

EXTERNAL FI-FI

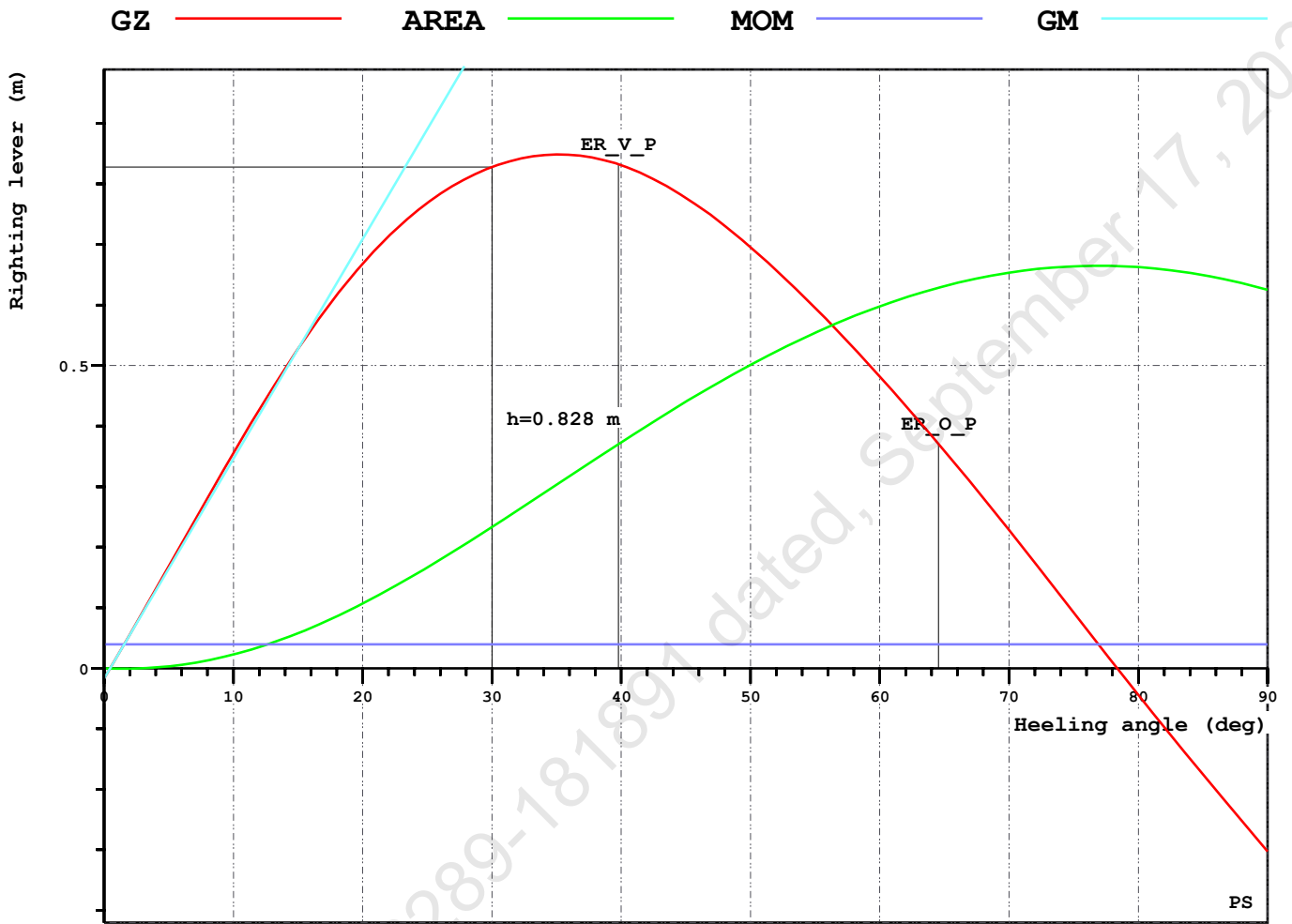

IS CODE TOWING - Self Tripping

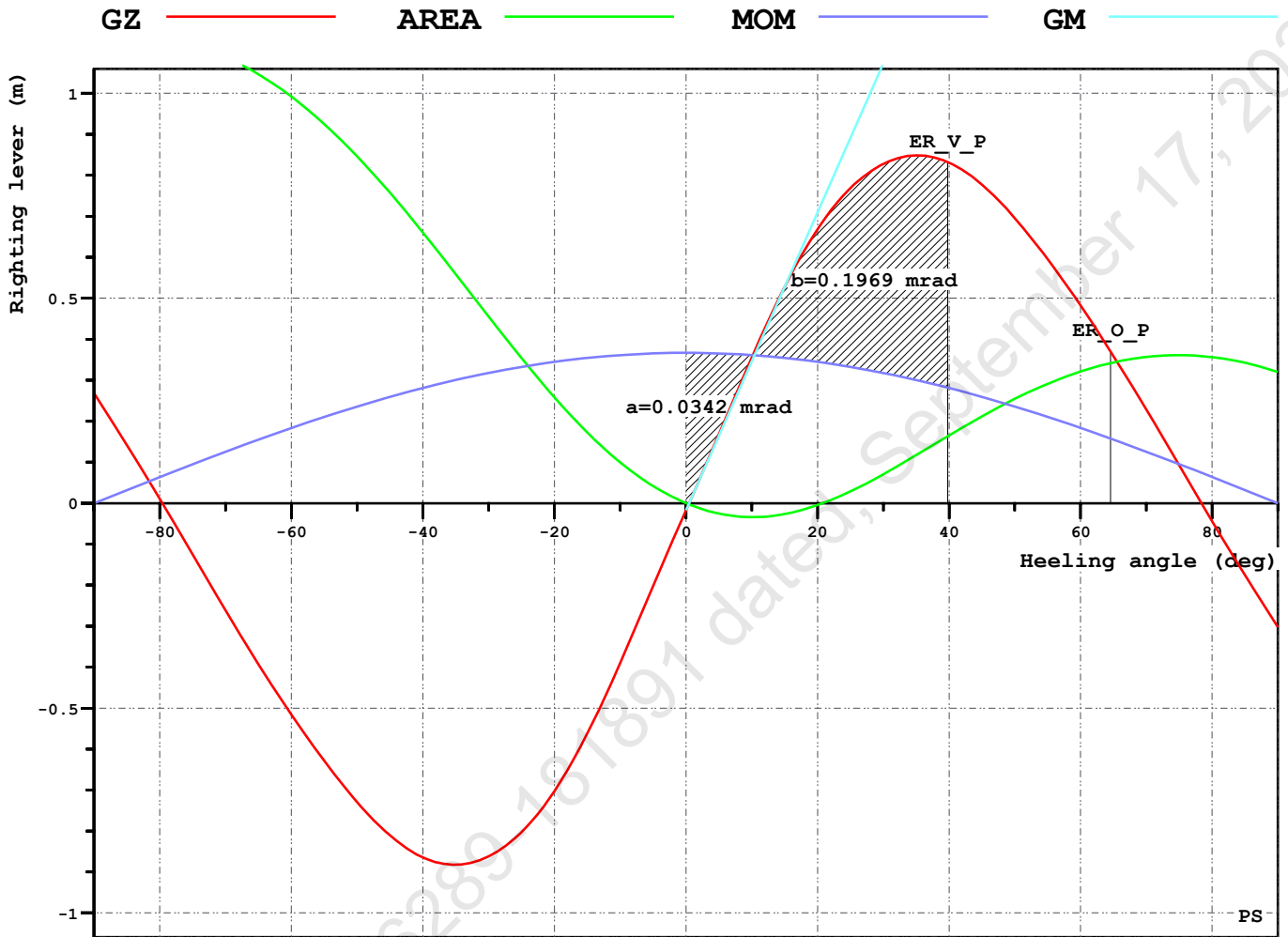

IS CODE TOWING - Tow Tripping

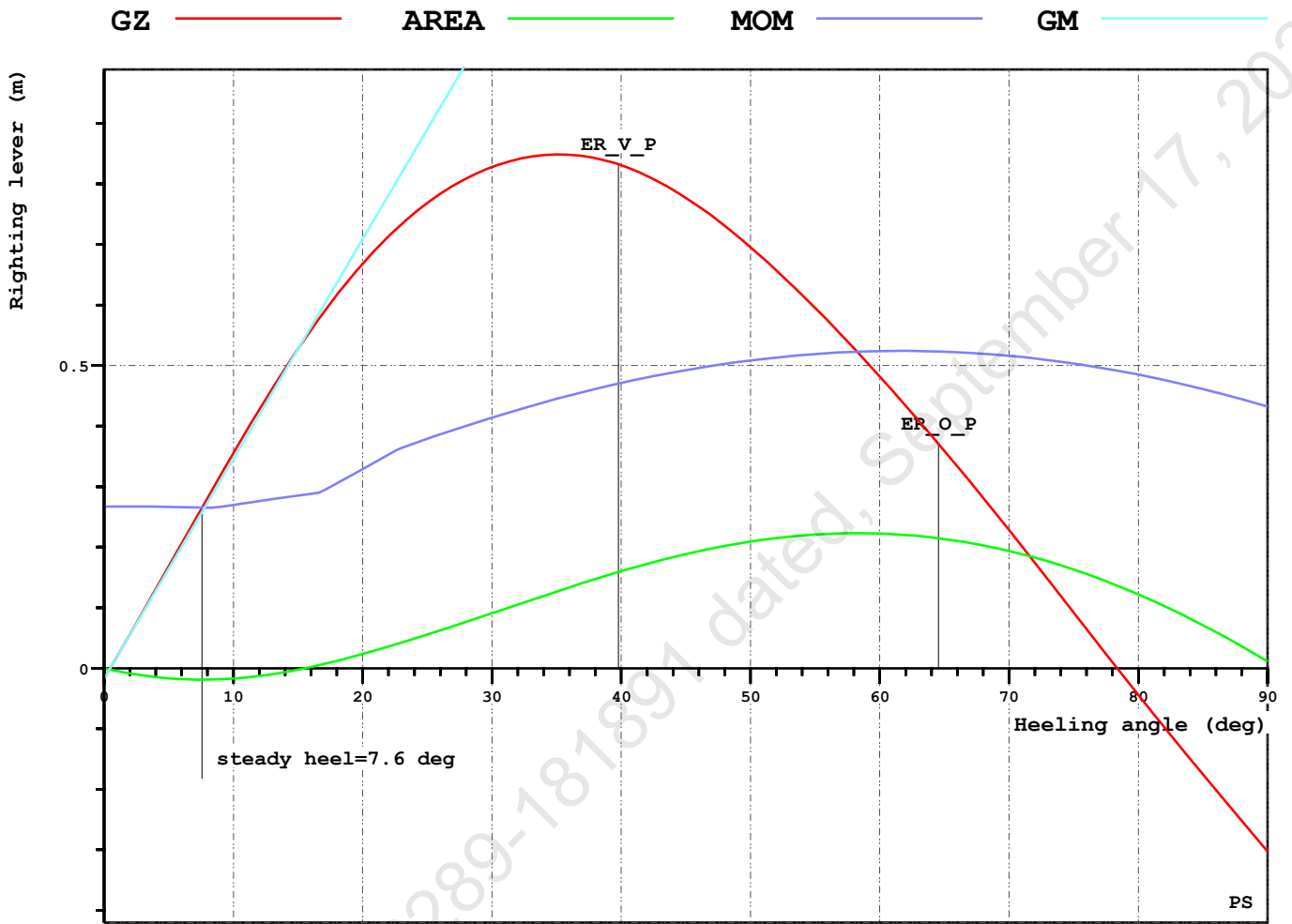

INTACT STABILITY CRITERIA

RCR	TEXT	REQ	ATTN UNIT	STAT
AREA30	Area under GZ curve up to 30 deg.	0.055	0.254 mrad	OK
AREA40	Area under GZ curve up to 40 deg.	0.090	0.397 mrad	OK
AREA3040	Area under GZ curve btw. 30-40 deg.	0.030	0.144 mrad	OK
GZ0.2	Max GZ > 0.2	0.200	0.849 m	OK
MAXGZ25	Max. GZ at an angle > 25 deg.	25.000	35.195 deg	OK
GM0.15	GM > 0.15 m	0.150	2.080 m	OK
V.IMOWEATHER	IMO weather criterion	1.000	1.921	OK
IMO.WIND_HEEL	Wind Heel <16 or <=80% of dk imm.	9.393	1.417 deg	OK
FIFI_GZ	Min. GZ for Fire fighter Ships	0.079	0.828 m	OK
2020IS-B2.8.4.2	AreaA>=AreaB	1.000	5.759	OK
2020IS-B2.8.4.3	Max. heel, tow-tr.	39.773	7.565 deg	OK

Refer IRS Letter E-126289-181897 dated, September 17, 2021

GZ CURVE DATA

HEEL deg	T m	TR m	GZ m	AREA mrad
0.0	4.192	-0.145	-0.017	0.000
0.5	4.192	-0.145	0.000	0.000
10.0	4.106	-0.123	0.356	0.030
20.0	3.897	-0.153	0.669	0.121
30.0	3.626	-0.447	0.828	0.254
40.0	3.289	-0.866	0.831	0.401
50.0	2.870	-1.293	0.696	0.536
60.0	2.377	-1.692	0.482	0.639
70.0	1.827	-2.029	0.229	0.701
80.0	1.231	-2.284	-0.044	0.718
90.0	0.621	-2.374	-0.303	0.687

RELEVANT OPENINGS

NAME	TEXT	WT	X m	Y m	Z m	IMMA deg	IMMR m
ER_V_P	ER_INLET_P	UNPROTECTED	13.373	2.300	6.300	39.8	2.077
ER_V_S	ER_INLET_S	UNPROTECTED	13.373	-2.300	6.300	-	2.114
ER_O_P	ER_OUT_P	UNPROTECTED	14.000	1.500	8.400	64.5	4.186
ER_O_S	ER_OUT_S	UNPROTECTED	14.000	-1.500	8.400	-	4.211

LC02 - ARRIVAL (10% CONSUMABLES)

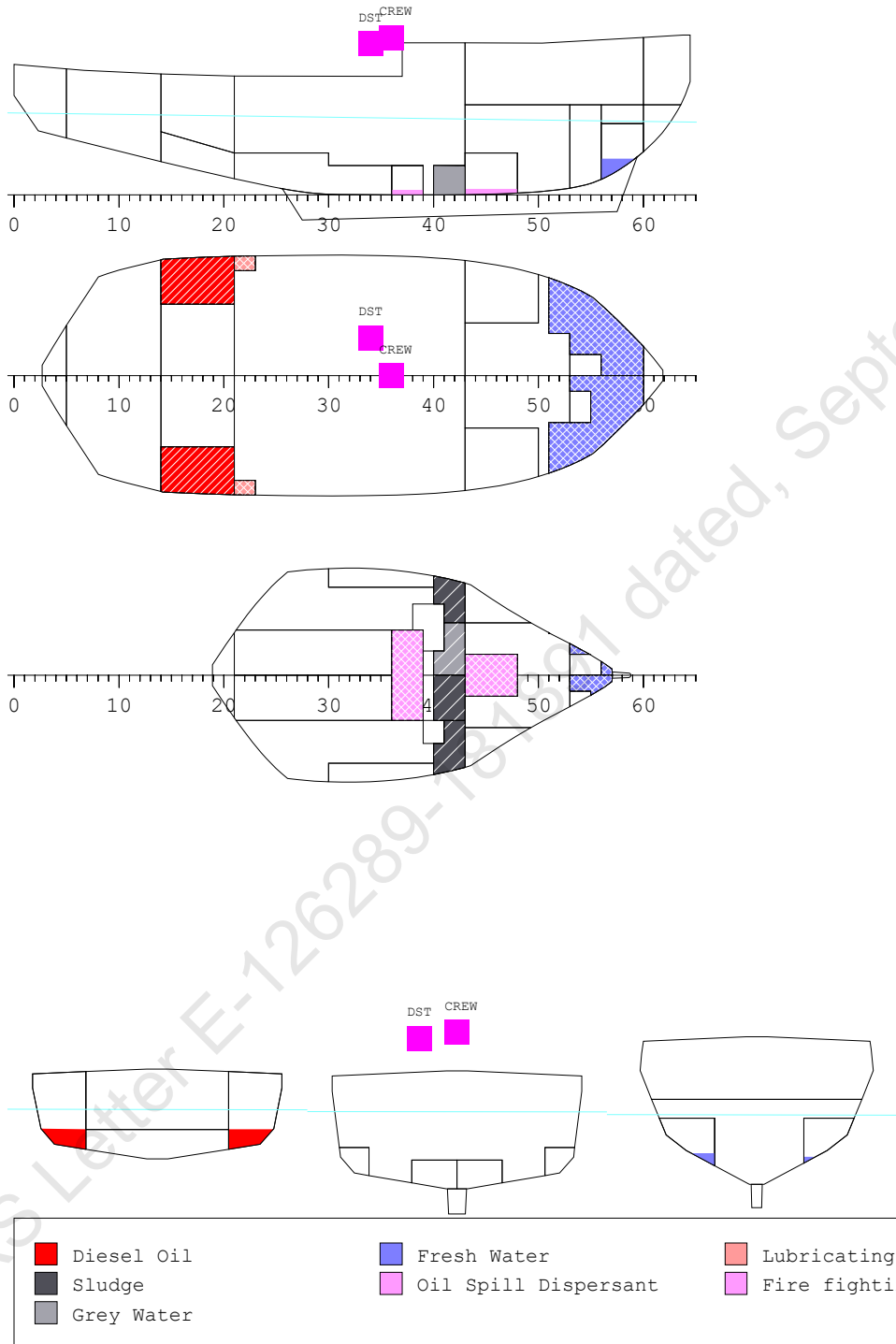

LC02 - ARRIVAL (10% CONSUMABLES)

Floating Position - Intact condition

Draught at AP (moulded)	3.902 m
Draught at FP (moulded)	3.479 m
Mean Draught (moulded)	3.691 m
Trim (+ by Bow)	-0.424 m
Heel (+ PS)	0.1 deg
KM above moulded BL	6.477 m
KG above moulded BL	4.395 m
GM0 (solid)	2.082 m
Free Surface Correction	0.196 m
GM (liquid)	1.886 m
Density of Water	1.025 t/m3

LCB : 16.147 m Fwd of AP
LCF : 15.035 m Fwd of AP

MCT : 6.489 tm/cm
TPC : 3.186 t/cm

LOAD SUMMARY TABLE

NAME	LOAD	MASS t	LCG m	TCG m	VCG m
Crew	CREW	1.0	18.000	0.000	7.500
Oil Spill Dispersant	DISPERSANT	0.8	18.743	0.000	0.141
Diesel Oil	DO	12.7	9.002	0.000	2.311
Deck Store	DST	0.2	17.000	1.800	7.200
Fire fighting Foam	FOAM	0.9	22.635	0.000	0.175
Fresh Water	FW	3.4	27.405	0.359	1.306
Grey Water	GWT	3.5	20.842	1.034	0.741
Lubricating Oil	LO	0.4	11.003	0.000	2.781
Sludge	SLU	26.3	20.768	-0.434	1.102
Deadweight		49.3	18.053	-0.125	1.537
Lightweight		695.8	16.043	0.006	4.597
Deadweight		49.3	18.053	-0.125	1.537
Total weight		745.1	16.176	-0.003	4.395

LOADING COMPONENTS

Diesel Oil (Density 0.860 t/m3)

NAME	PURP	FILL %	MASS t	VOL m3	LCG m	TCG m	VCG m	FRSM tm
R.FODAYTK.P	DO	25.0	6.3	7.4	8.811	4.540	3.752	4.08
R.FODAYTK.S	DO	25.0	6.3	7.4	8.811	-4.540	3.752	4.08
R.FOTK.1S	DO	0.0	0.0	0.0	23.089	-3.686	2.307	0.00
R.FOTK.1P	DO	0.0	0.0	0.0	23.089	3.686	2.307	0.00
R.FOTK.2P	DO	0.0	0.0	0.0	14.194	1.037	1.041	0.00
R.FOTK.2S	DO	0.0	0.0	0.0	14.194	-1.037	1.041	0.00
R.FOTK.3P	DO	0.0	0.0	0.0	17.384	4.764	1.434	0.00
R.FOTK.3S	DO	0.0	0.0	0.0	17.384	-4.764	1.434	0.00
R.FOTK.4C	DO	0.0	0.0	0.0	8.705	0.000	1.932	76.61
TOTAL			12.7	14.7				84.76

Fresh Water (Density 1.0 t/m3)

NAME	PURP	FILL %	MASS t	VOL m3	LCG m	TCG m	VCG m	FRSM tm
R.FWTK.P	FW	10.0	1.7	1.7	27.551	1.914	2.570	16.56
R.FWTK.S	FW	10.0	1.7	1.7	27.632	-1.659	2.506	19.88
TOTAL			3.4	3.4				36.44

Lub Oil (Density 0.860 t/m3)

NAME	PURP	FILL %	MASS t	VOL m3	LCG m	TCG m	VCG m	FRSM tm
R.LOTK.P	LO	10.0	0.2	0.2	11.001	5.423	4.122	0.06
R.LOTK.S	LO	10.0	0.2	0.2	11.001	-5.423	4.122	0.06
TOTAL			0.4	0.5				0.13

FOAM (Density 1.0 t/m3)

NAME	PURP	FILL %	MASS t	VOL m3	LCG m	TCG m	VCG m	FRSM tm
R.FOAMTK	FOAM	10.0	0.9	0.9	22.738	0.000	1.044	1.63
TOTAL			0.9	0.9				1.63

DISPERSANT (Density 1.0 t/m3)

NAME	PURP	FILL %	MASS t	VOL m3	LCG m	TCG m	VCG m	FRSM tm
R.DISPERSANTTK	DISPERSANT	10.0	0.8	0.8	18.749	0.000	0.752	9.74
TOTAL			0.8	0.8				9.74

STORES

NAME	PURP	MASS t	LCG m	TCG m	VCG m
STORES	MASS	0.2	17.000	1.800	7.200
TOTAL		0.2	17.000	1.800	7.200

CREW

NAME	PURP	MASS t	LCG m	TCG m	VCG m
CREW	MASS	1.0	18.000	0.000	7.500
TOTAL		1.0	18.000	0.000	7.500

INTACT STABILITY CHECK PLOT

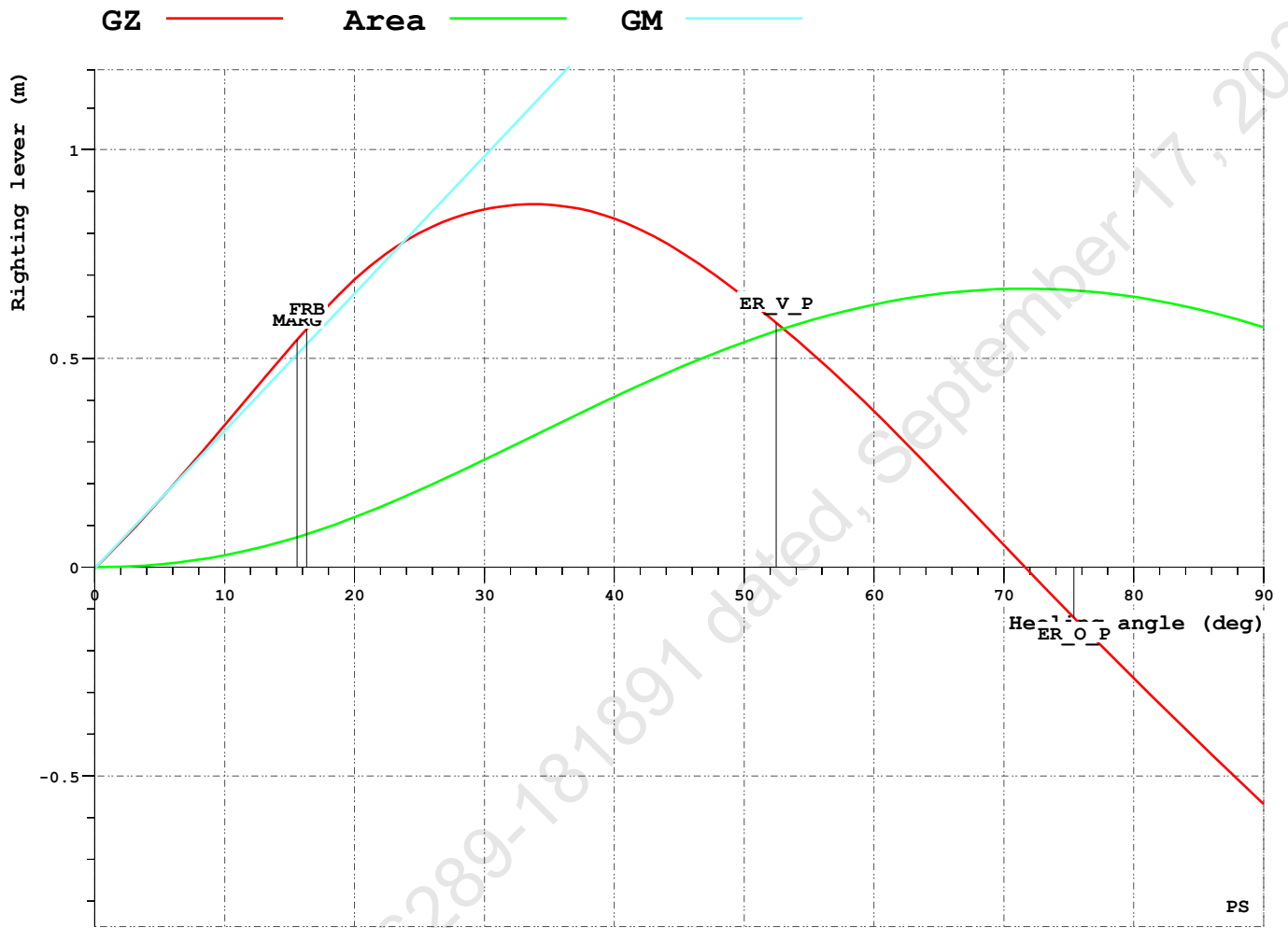

IMO WEATHER CRITERIA

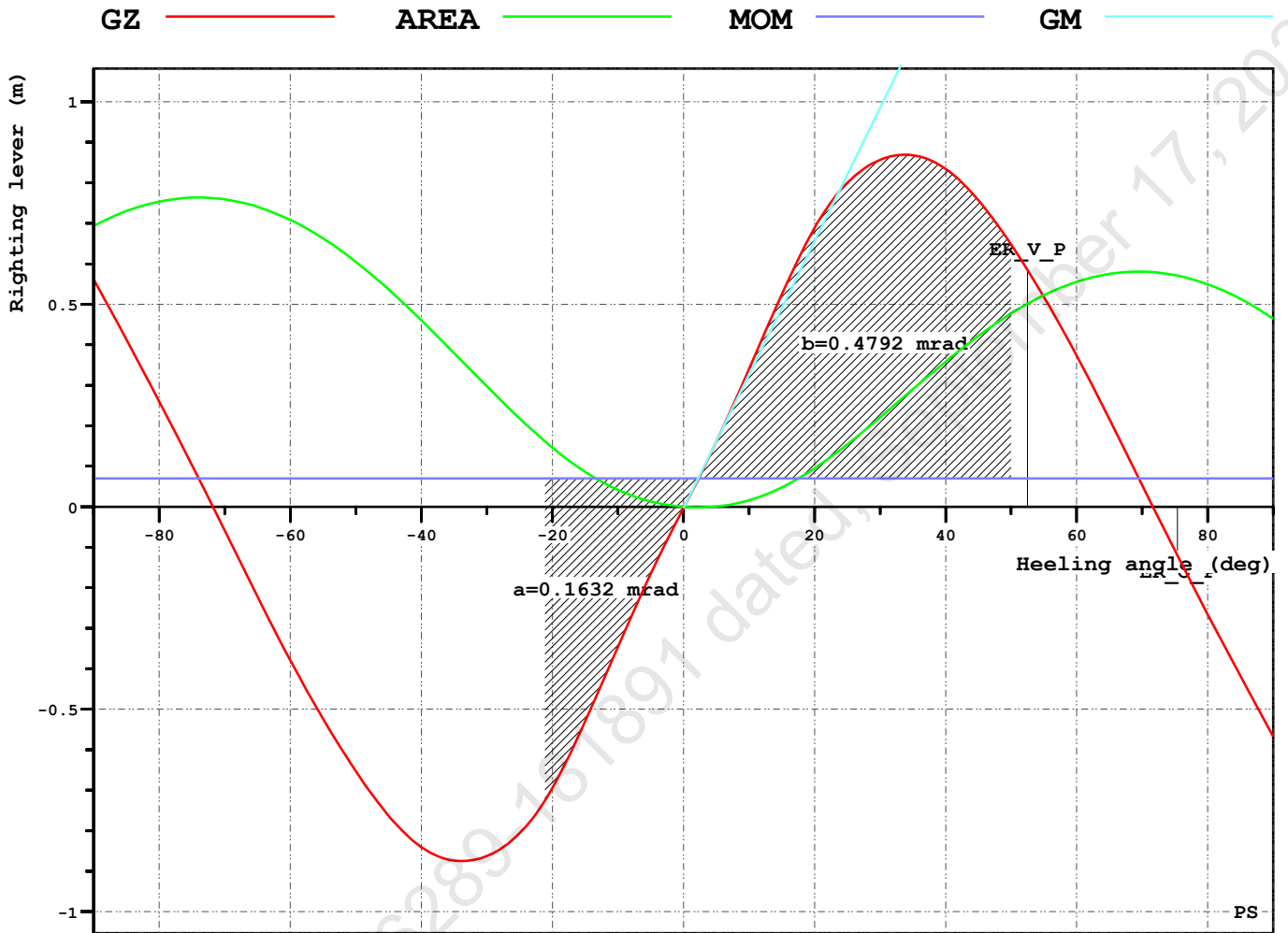

EXTERNAL FI-FI

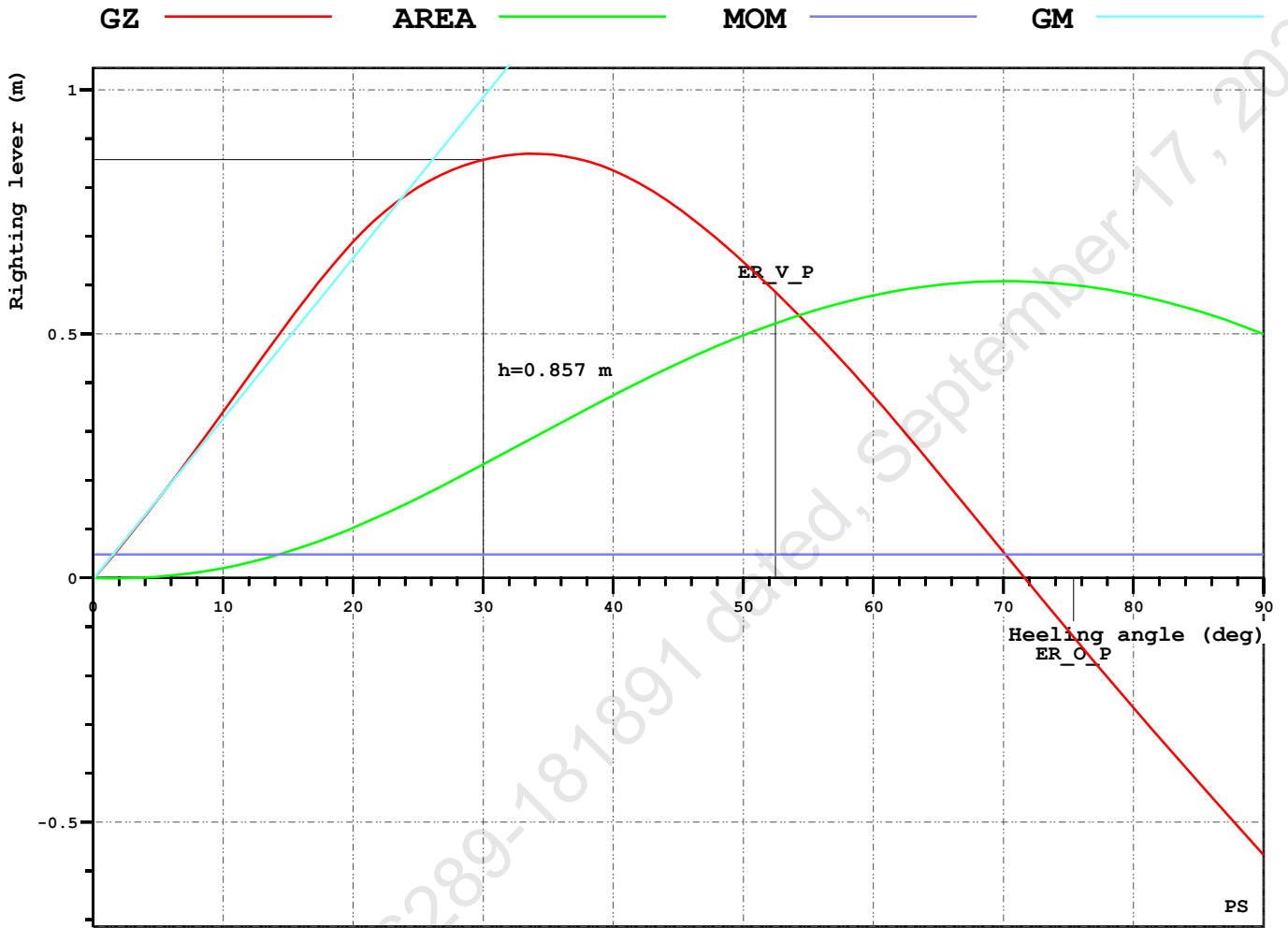

IS CODE TOWING - Self Tripping

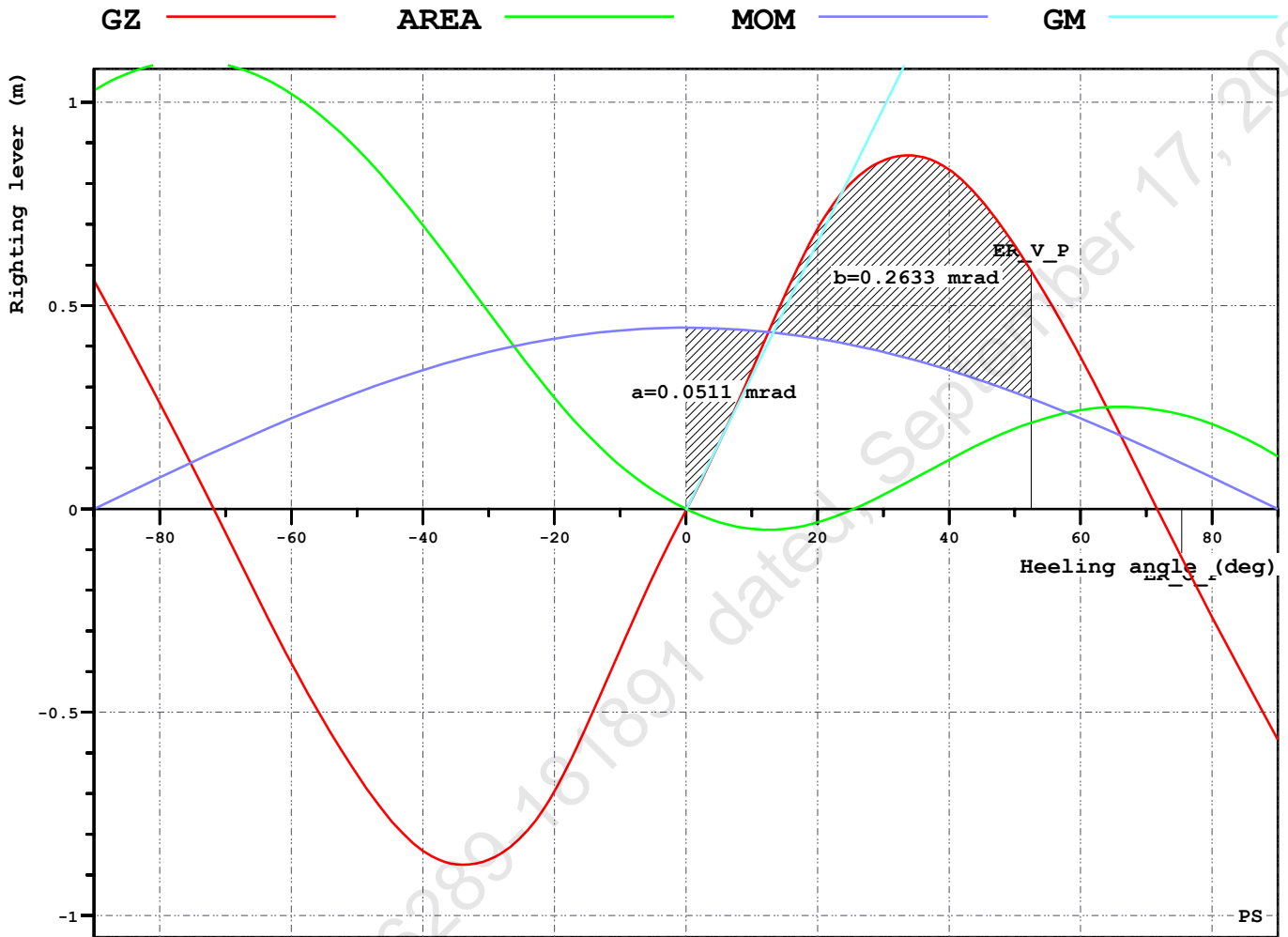

IS CODE TOWING - Tow Tripping

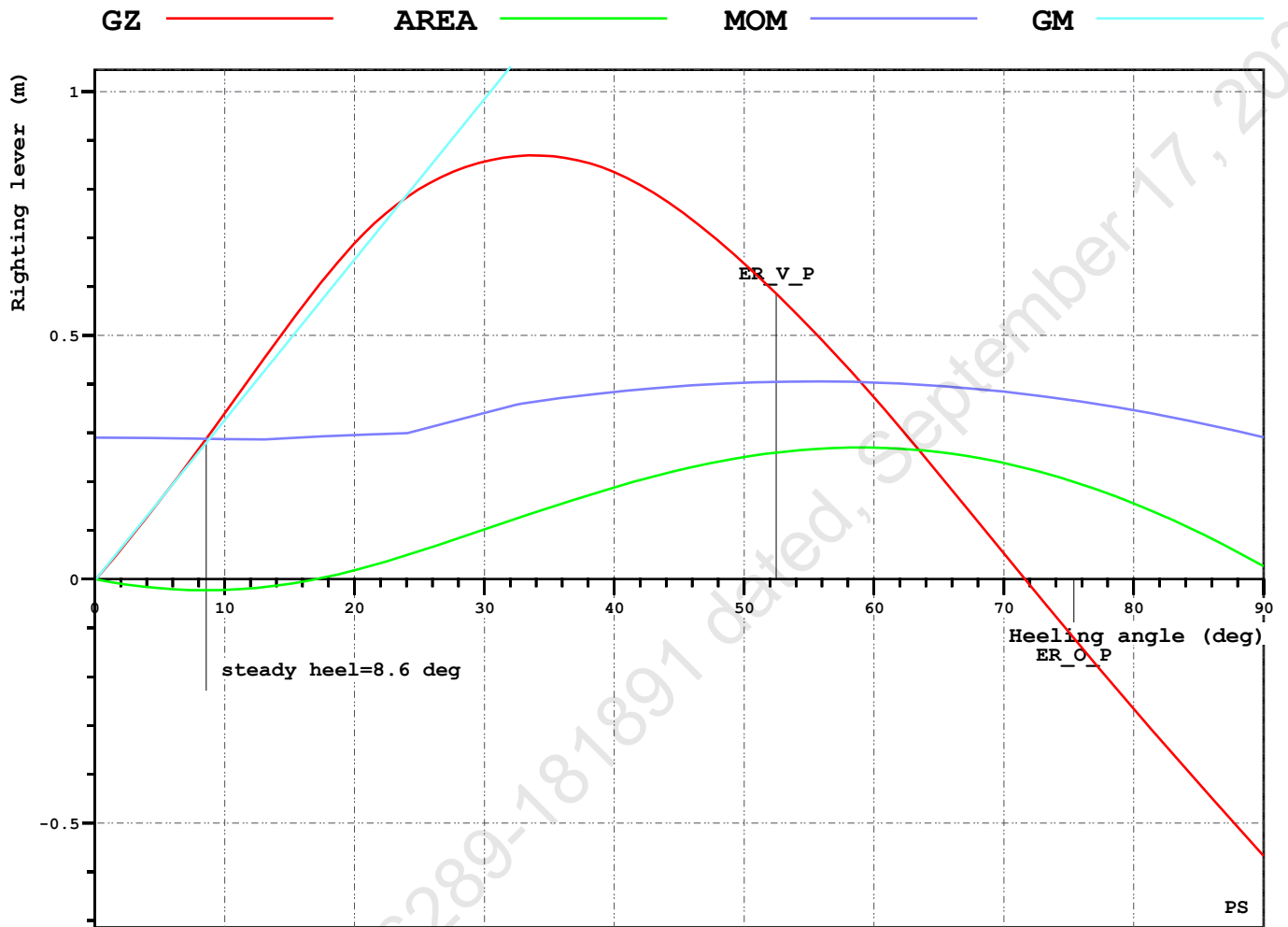

INTACT STABILITY CRITERIA

RCR	TEXT	REQ	ATTN UNIT	STAT
AREA30	Area under GZ curve up to 30 deg.	0.055	0.257 mrad	OK
AREA40	Area under GZ curve up to 40 deg.	0.090	0.408 mrad	OK
AREA3040	Area under GZ curve btw. 30-40 deg.	0.030	0.150 mrad	OK
GZ0.2	Max GZ > 0.2	0.200	0.869 m	OK
MAXGZ25	Max. GZ at an angle > 25 deg.	25.000	33.812 deg	OK
GM0.15	GM > 0.15 m	0.150	1.886 m	OK
V.IMOWEATHER	IMO weather criterion	1.000	2.937	OK
IMO.WIND_HEEL	Wind Heel <16 or <=80% of dk imm.	13.060	1.582 deg	OK
FIFI_GZ	Min. GZ for Fire fighter Ships	0.096	0.857 m	OK
2020IS-B2.8.4.2	AreaA>=AreaB	1.000	5.147	OK
2020IS-B2.8.4.3	Max. heel, tow-tr.	52.474	8.596 deg	OK

Refer IRS Letter E-126289-181897 dated, September 17, 2021

GZ CURVE DATA

HEEL deg	T m	TR m	GZ m	AREA mrad
0.0	3.691	-0.424	-0.003	0.000
0.1	3.691	-0.424	0.000	0.000
10.0	3.610	-0.388	0.340	0.028
20.0	3.372	-0.272	0.689	0.119
30.0	3.034	-0.299	0.857	0.257
40.0	2.590	-0.533	0.835	0.408
50.0	2.073	-0.816	0.648	0.539
60.0	1.507	-1.085	0.374	0.629
70.0	0.905	-1.312	0.053	0.666
80.0	0.299	-1.426	-0.266	0.648
90.0	-0.295	-1.562	-0.568	0.575

RELEVANT OPENINGS

NAME	TEXT	WT	X m	Y m	Z m	IMMA deg	IMMR m
ER_V_P	ER_INLET_P	UNPROTECTED	13.373	2.300	6.300	52.5	2.569
ER_V_S	ER_INLET_S	UNPROTECTED	13.373	-2.300	6.300	-	2.576
ER_O_P	ER_OUT_P	UNPROTECTED	14.000	1.500	8.400	75.4	4.679
ER_O_S	ER_OUT_S	UNPROTECTED	14.000	-1.500	8.400	-	4.683

LC03 - LC01+CRANE LOAD(3T Load)

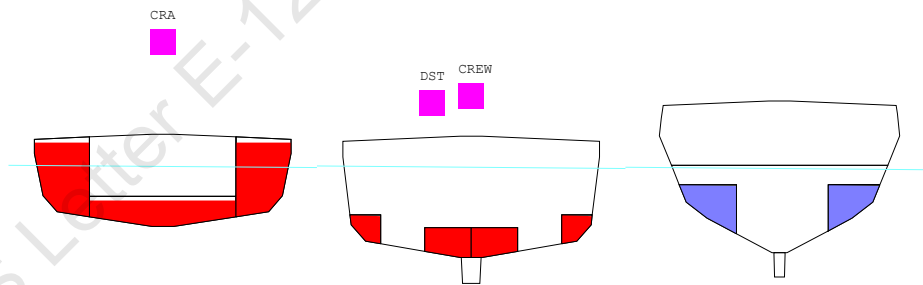
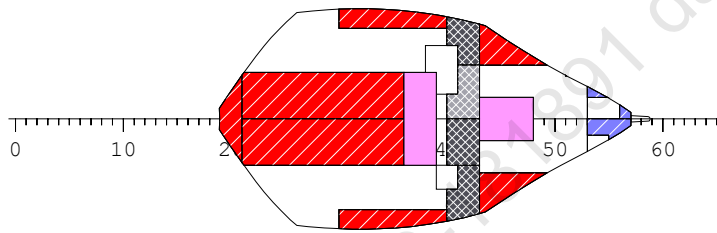
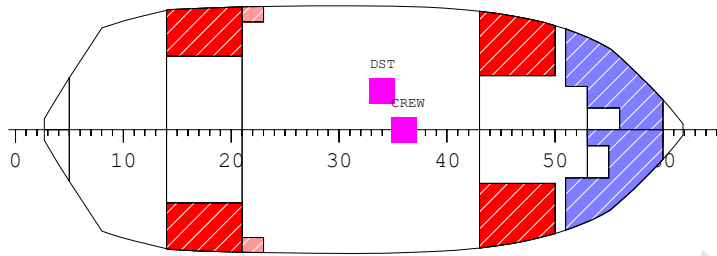
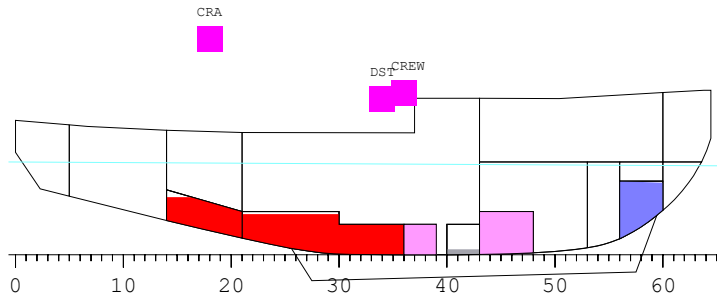

Diesel Oil	Fresh Water	Lubricating Oil
Sludge	Oil Spill Dispersant	Fire fighting Foam
Grey Water		

LC03 - LC01+CRANE LOAD(3T Load)

Floating Position - Intact condition

Draught at AP (moulded)	4.286 m
Draught at FP (moulded)	4.114 m
Mean Draught (moulded)	4.200 m
Trim (+ by Bow)	-0.172 m
Heel (+ PS)	0.5 deg
KM above moulded BL	6.301 m
KG above moulded BL	4.078 m
GM0 (solid)	2.222 m
Free Surface Correction	0.161 m
GM (liquid)	2.061 m
Density of Water	1.025 t/m3

LCB : 16.141 m Fwd of AP
LCF : 15.082 m Fwd of AP

MCT : 7.182 tm/cm
TPC : 3.329 t/cm

LOAD SUMMARY TABLE

NAME	LOAD	MASS t	LCG m	TCG m	VCG m
Crane	CRA	3.0	9.000	0.000	10.000
Crew	CREW	1.0	18.000	0.000	7.500
Oil Spill Dispersant	DISPERSANT	8.1	18.749	0.000	0.752
Diesel Oil	DO	149.7	13.781	0.000	2.274
Deck Store	DST	2.0	17.000	1.800	7.200
Fire fighting Foam	FOAM	9.4	22.738	0.000	1.044
Fresh Water	FW	32.3	27.584	0.119	2.494
Grey Water	GWT	0.4	20.745	0.546	0.148
Lubricating Oil	LO	4.0	11.001	0.000	4.055
Sludge	SLU	2.8	20.800	-0.202	0.501
Deadweight		212.7	16.498	0.033	2.381
Lightweight		695.8	16.043	0.006	4.597
Deadweight		212.7	16.498	0.033	2.381
Total weight		908.5	16.149	0.012	4.078

LOADING COMPONENTS

Diesel Oil (Density 0.860 t/m3)

NAME	PURP	FILL %	MASS t	VOL m3	LCG m	TCG m	VCG m	FRSM tm
R.FODAYTK.P	DO	95.0	24.1	28.0	8.811	4.540	3.752	4.08
R.FODAYTK.S	DO	95.0	24.1	28.0	8.811	-4.540	3.752	4.08
R.FOTK.1S	DO	95.0	15.5	18.1	23.089	-3.686	2.307	0.00
R.FOTK.1P	DO	95.0	15.5	18.1	23.089	3.686	2.307	0.00
R.FOTK.2P	DO	95.0	18.8	21.9	14.194	1.037	1.041	0.00
R.FOTK.2S	DO	95.0	18.8	21.9	14.194	-1.037	1.041	0.00
R.FOTK.3P	DO	95.0	5.6	6.5	17.384	4.764	1.434	0.00
R.FOTK.3S	DO	95.0	5.6	6.5	17.384	-4.764	1.434	0.00
R.FOTK.4C	DO	95.0	21.7	25.3	8.705	0.000	1.932	76.61
TOTAL			149.7	174.1				84.76

Fresh Water (Density 1.0 t/m3)

NAME	PURP	FILL %	MASS t	VOL m3	LCG m	TCG m	VCG m	FRSM tm
R.FWTK.P	FW	95.0	16.1	16.1	27.551	1.914	2.570	16.56
R.FWTK.S	FW	95.0	16.3	16.3	27.632	-1.659	2.506	19.88
TOTAL			32.3	32.3				36.44

Lub Oil (Density 0.860 t/m3)

NAME	PURP	FILL %	MASS t	VOL m3	LCG m	TCG m	VCG m	FRSM tm
R.LOTK.P	LO	95.0	2.0	2.2	11.001	5.423	4.122	0.06
R.LOTK.S	LO	95.0	2.0	2.2	11.001	-5.423	4.122	0.06
TOTAL			4.0	4.4				0.13

FOAM (Density 1.0 t/m3)

NAME	PURP	FILL %	MASS t	VOL m3	LCG m	TCG m	VCG m	FRSM tm
R.FOAMTK	FOAM	100.0	9.4	9.4	22.738	0.000	1.044	1.63
TOTAL			9.4	9.4				1.63

DISPERSANT (Density 1.0 t/m3)

NAME	PURP	FILL %	MASS t	VOL m3	LCG m	TCG m	VCG m	FRSM tm
R.DISPERSANTTK	DISPERSANT	100.0	8.1	8.1	18.749	0.000	0.752	9.74
TOTAL			8.1	8.1				9.74

STORES

NAME	PURP	MASS t	LCG m	TCG m	VCG m
STORES	MASS	2.0	17.000	1.800	7.200
TOTAL		2.0	17.000	1.800	7.200

CREW

NAME	PURP	MASS t	LCG m	TCG m	VCG m
CREW	MASS	1.0	18.000	0.000	7.500
TOTAL		1.0	18.000	0.000	7.500

CRANE

NAME	PURP	MASS t	LCG m	TCG m	VCG m
CRANE-PAYLO	MASS	3.0	9.000	0.000	10.000
TOTAL		3.0	9.000	0.000	10.000

INTACT STABILITY CHECK PLOT

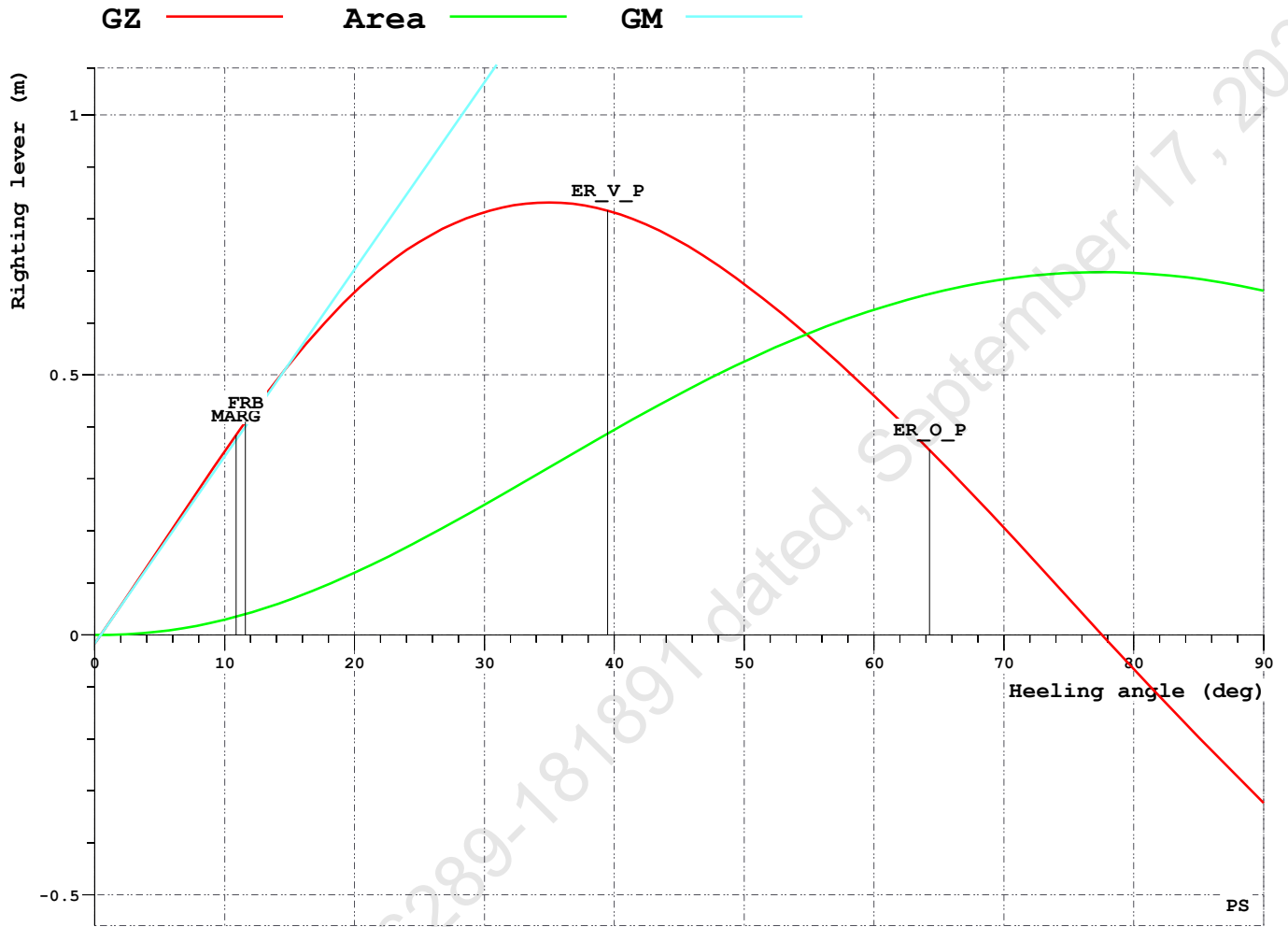

IMO WEATHER CRITERIA

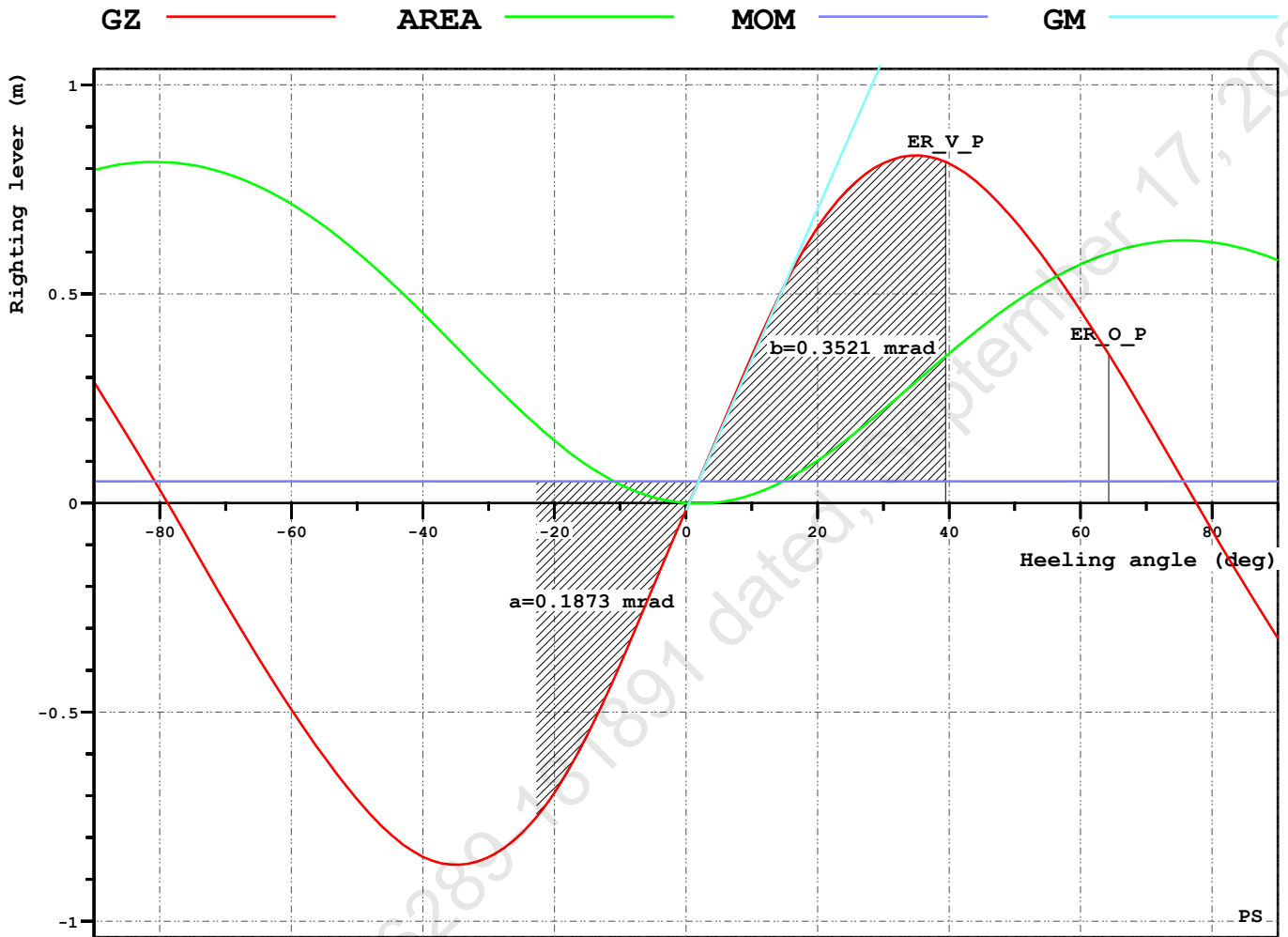

IS CODE LIFTING - Residual Area

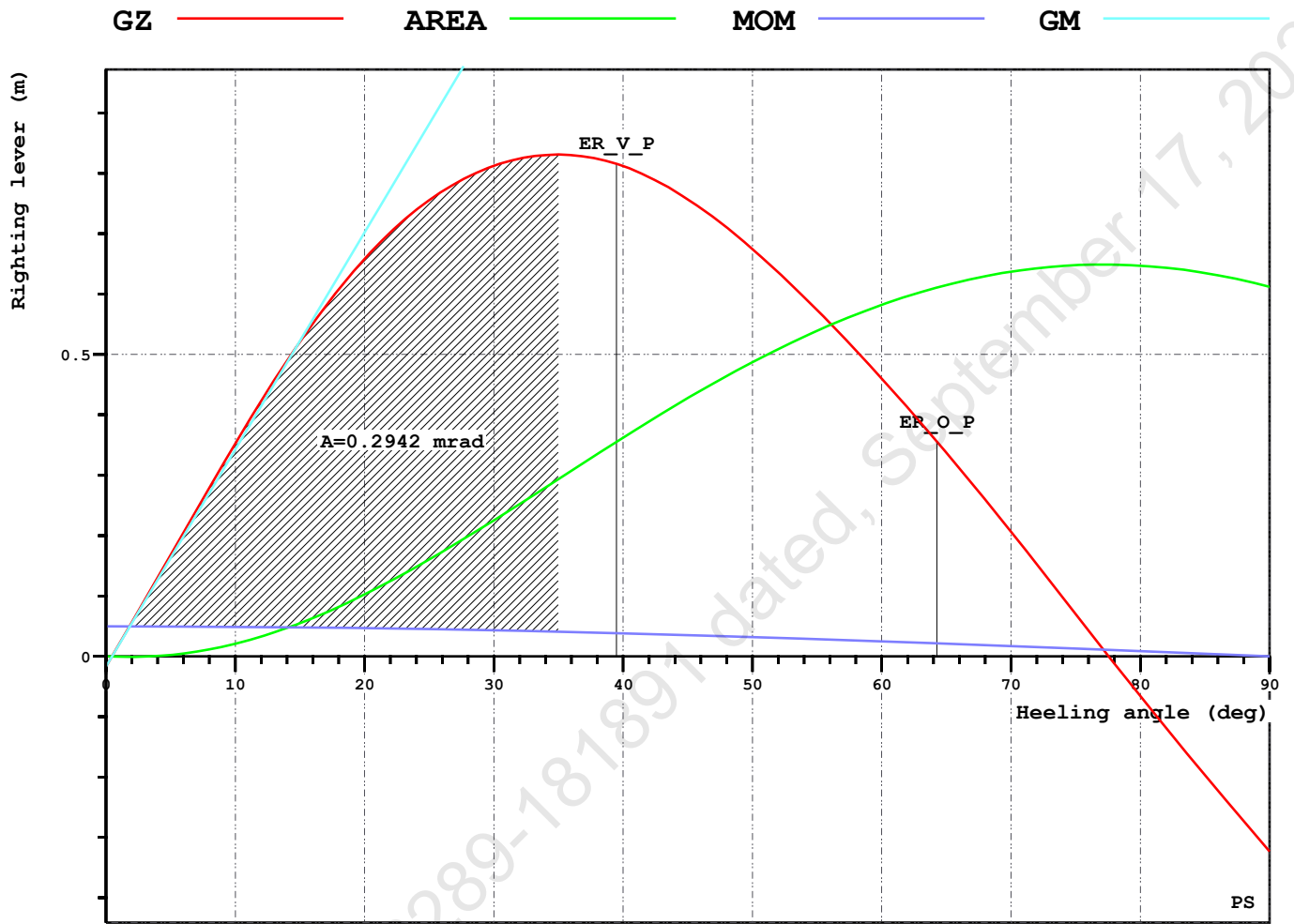

IS CODE LIFTING - Equilibrium angle

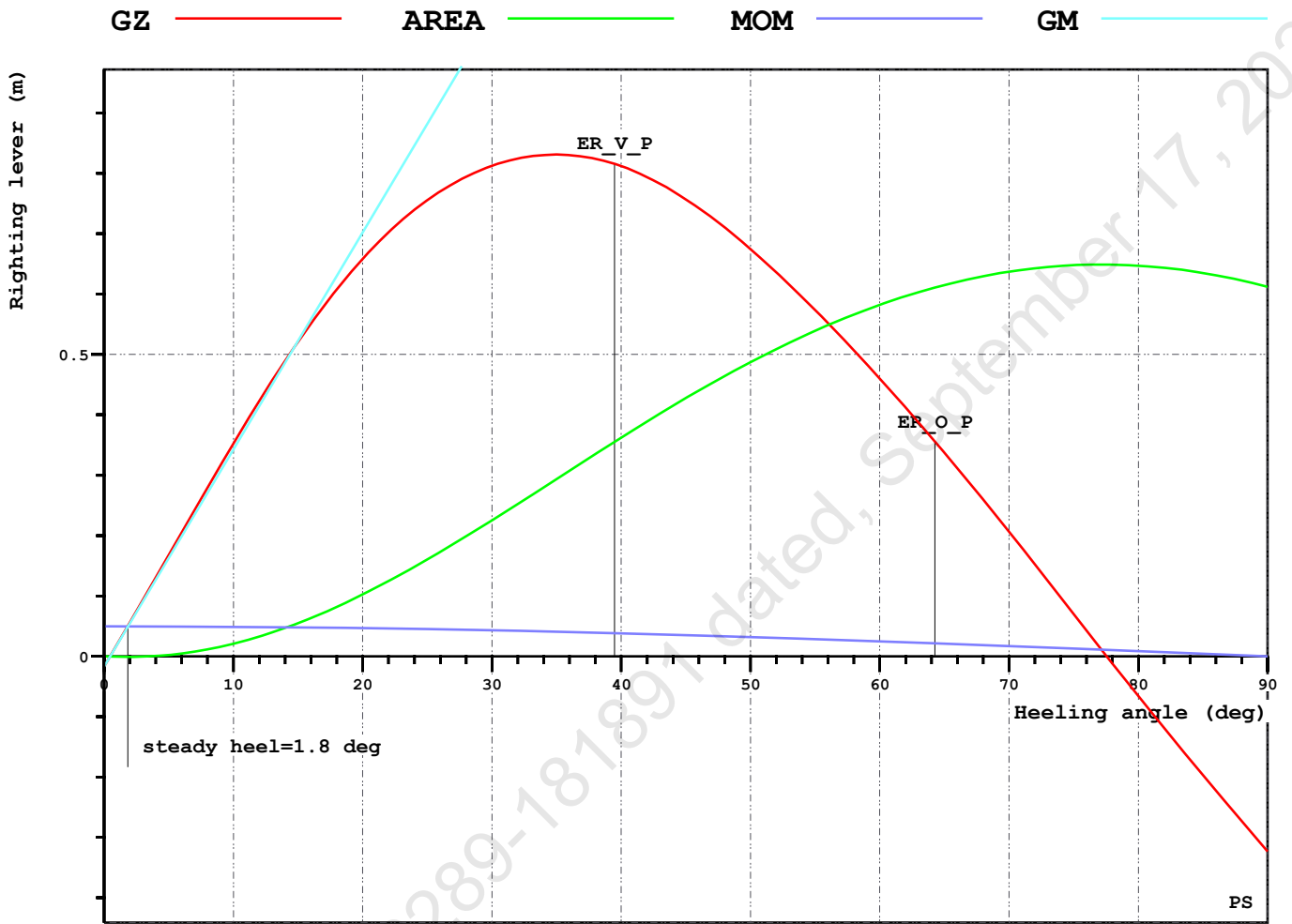

INTACT STABILITY CRITERIA

RCR	TEXT	REQ	ATTN UNIT	STAT
AREA30	Area under GZ curve up to 30 deg.	0.055	0.250 mrad	OK
AREA40	Area under GZ curve up to 40 deg.	0.090	0.387 mrad	OK
AREA3040	Area under GZ curve btw. 30-40 deg.	0.030	0.137 mrad	OK
GZ0.2	Max GZ > 0.2	0.200	0.831 m	OK
MAXGZ25	Max. GZ at an angle > 25 deg.	25.000	34.962 deg	OK
GM0.15	GM > 0.15 m	0.150	2.061 m	OK
V.IMOWEATHER	IMO weather criterion	1.000	1.880	OK
IMO.WIND_HEEL	Wind Heel <16 or <=80% of dk imm.	9.289	1.424 deg	OK
2020IS-B2.9.7.1.2	Eq. angle less than 10 deg. or dk. imm.	11.612	1.831 deg	OK
2020IS-B2.9.7.1.1	Resid. righting area > 0.08 mrad	0.080	0.294 mrad	OK

Refer IRS Letter E-126289-181897 dated, September 17, 2021

GZ CURVE DATA

HEEL deg	T m	TR m	GZ m	AREA mrad
0.0	4.200	-0.172	-0.017	0.000
0.5	4.200	-0.172	0.000	0.000
10.0	4.114	-0.151	0.353	0.029
20.0	3.907	-0.186	0.659	0.119
30.0	3.639	-0.491	0.813	0.250
40.0	3.303	-0.921	0.812	0.394
50.0	2.888	-1.357	0.675	0.525
60.0	2.397	-1.765	0.460	0.625
70.0	1.848	-2.108	0.206	0.684
80.0	1.253	-2.366	-0.066	0.696
90.0	0.643	-2.457	-0.323	0.662

RELEVANT OPENINGS

NAME	TEXT	WT	X m	Y m	Z m	IMMA deg	IMMR m
ER_V_P	ER_INLET_P	UNPROTECTED	13.373	2.300	6.300	39.5	2.066
ER_V_S	ER_INLET_S	UNPROTECTED	13.373	-2.300	6.300	-	2.104
ER_O_P	ER_OUT_P	UNPROTECTED	14.000	1.500	8.400	64.3	4.176
ER_O_S	ER_OUT_S	UNPROTECTED	14.000	-1.500	8.400	-	4.201

LC04 - LC02+CRANE LOAD(3T Load)

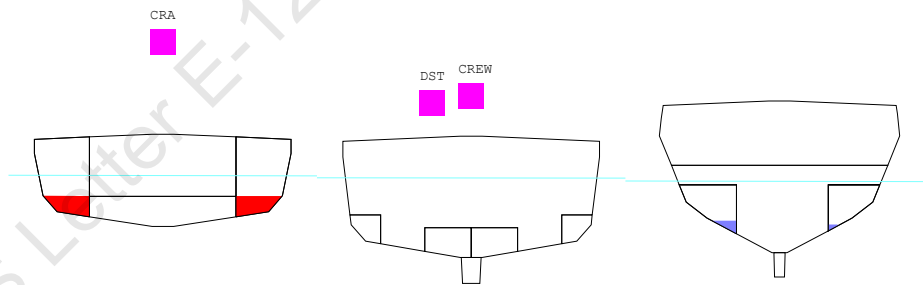
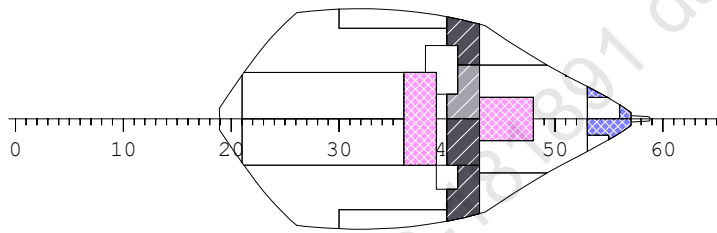
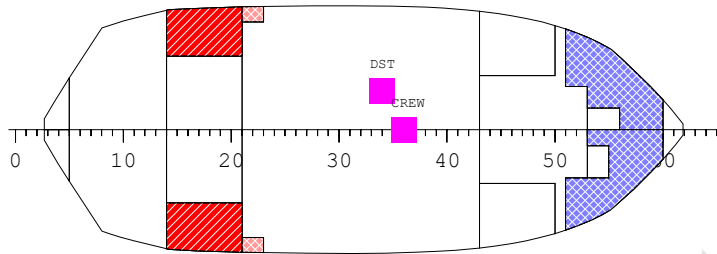
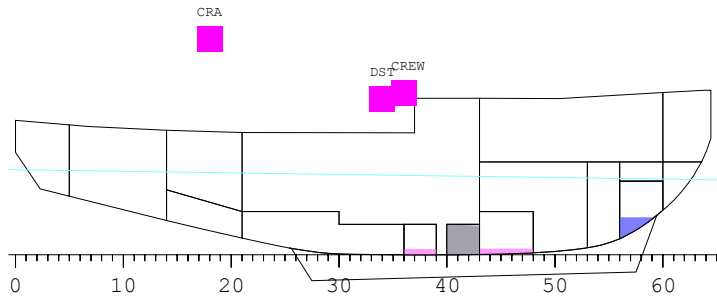

Diesel Oil	Fresh Water	Lubricating Oil
Sludge	Oil Spill Dispersant	Fire fighting Foam
Grey Water		

LC04 - LC02+CRANE LOAD(3T Load)

Floating Position - Intact condition

Draught at AP (moulded)	3.926 m
Draught at FP (moulded)	3.472 m
Mean Draught (moulded)	3.699 m
Trim (+ by Bow)	-0.454 m
Heel (+ PS)	0.1 deg
KM above moulded BL	6.474 m
KG above moulded BL	4.417 m
GM0 (solid)	2.057 m
Free Surface Correction	0.196 m
GM (liquid)	1.861 m
Density of Water	1.025 t/m ³

LCB	:	16.116 m Fwd of AP
LCF	:	15.020 m Fwd of AP
MCT	:	6.504 tm/cm
TPC	:	3.189 t/cm

LOAD SUMMARY TABLE

NAME	LOAD	MASS t	LCG m	TCG m	VCG m
Crane	CRA	3.0	9.000	0.000	10.000
Crew	CREW	1.0	18.000	0.000	7.500
Oil Spill Dispersant	DISPERSANT	0.8	18.743	0.000	0.141
Diesel Oil	DO	12.7	9.002	0.000	2.311
Deck Store	DST	0.2	17.000	1.800	7.200
Fire fighting Foam	FOAM	0.9	22.635	0.000	0.175
Fresh Water	FW	3.4	27.405	0.359	1.306
Grey Water	GWT	3.5	20.842	1.034	0.741
Lubricating Oil	LO	0.4	11.003	0.000	2.781
Sludge	SLU	26.3	20.768	-0.434	1.102
Deadweight		52.3	17.534	-0.118	2.022
Lightweight		695.8	16.043	0.006	4.597
Deadweight		52.3	17.534	-0.118	2.022
Total weight		748.1	16.147	-0.003	4.417

LOADING COMPONENTS

Diesel Oil (Density 0.860 t/m3)

NAME	PURP	FILL %	MASS t	VOL m3	LCG m	TCG m	VCG m	FRSM tm
R.FODAYTK.P	DO	25.0	6.3	7.4	8.811	4.540	3.752	4.08
R.FODAYTK.S	DO	25.0	6.3	7.4	8.811	-4.540	3.752	4.08
R.FOTK.1S	DO	0.0	0.0	0.0	23.089	-3.686	2.307	0.00
R.FOTK.1P	DO	0.0	0.0	0.0	23.089	3.686	2.307	0.00
R.FOTK.2P	DO	0.0	0.0	0.0	14.194	1.037	1.041	0.00
R.FOTK.2S	DO	0.0	0.0	0.0	14.194	-1.037	1.041	0.00
R.FOTK.3P	DO	0.0	0.0	0.0	17.384	4.764	1.434	0.00
R.FOTK.3S	DO	0.0	0.0	0.0	17.384	-4.764	1.434	0.00
R.FOTK.4C	DO	0.0	0.0	0.0	8.705	0.000	1.932	76.61
TOTAL			12.7	14.7				84.76

Fresh Water (Density 1.0 t/m3)

NAME	PURP	FILL %	MASS t	VOL m3	LCG m	TCG m	VCG m	FRSM tm
R.FWTK.P	FW	10.0	1.7	1.7	27.551	1.914	2.570	16.56
R.FWTK.S	FW	10.0	1.7	1.7	27.632	-1.659	2.506	19.88
TOTAL			3.4	3.4				36.44

Lub Oil (Density 0.860 t/m3)

NAME	PURP	FILL %	MASS t	VOL m3	LCG m	TCG m	VCG m	FRSM tm
R.LOTK.P	LO	10.0	0.2	0.2	11.001	5.423	4.122	0.06
R.LOTK.S	LO	10.0	0.2	0.2	11.001	-5.423	4.122	0.06
TOTAL			0.4	0.5				0.13

FOAM (Density 1.0 t/m3)

NAME	PURP	FILL %	MASS t	VOL m3	LCG m	TCG m	VCG m	FRSM tm
R.FOAMTK	FOAM	10.0	0.9	0.9	22.738	0.000	1.044	1.63
TOTAL			0.9	0.9				1.63

DISPERSANT (Density 1.0 t/m3)

NAME	PURP	FILL %	MASS t	VOL m3	LCG m	TCG m	VCG m	FRSM tm
R.DISPERSANTTK	DISPERSANT	10.0	0.8	0.8	18.749	0.000	0.752	9.74
TOTAL			0.8	0.8				9.74

STORES

NAME	PURP	MASS t	LCG m	TCG m	VCG m
STORES	MASS	0.2	17.000	1.800	7.200
TOTAL		0.2	17.000	1.800	7.200

CREW

NAME	PURP	MASS t	LCG m	TCG m	VCG m
CREW	MASS	1.0	18.000	0.000	7.500
TOTAL		1.0	18.000	0.000	7.500

CRANE

NAME	PURP	MASS t	LCG m	TCG m	VCG m
CRANE	MASS	3.0	9.000	0.000	10.000
TOTAL		3.0	9.000	0.000	10.000

INTACT STABILITY CHECK PLOT

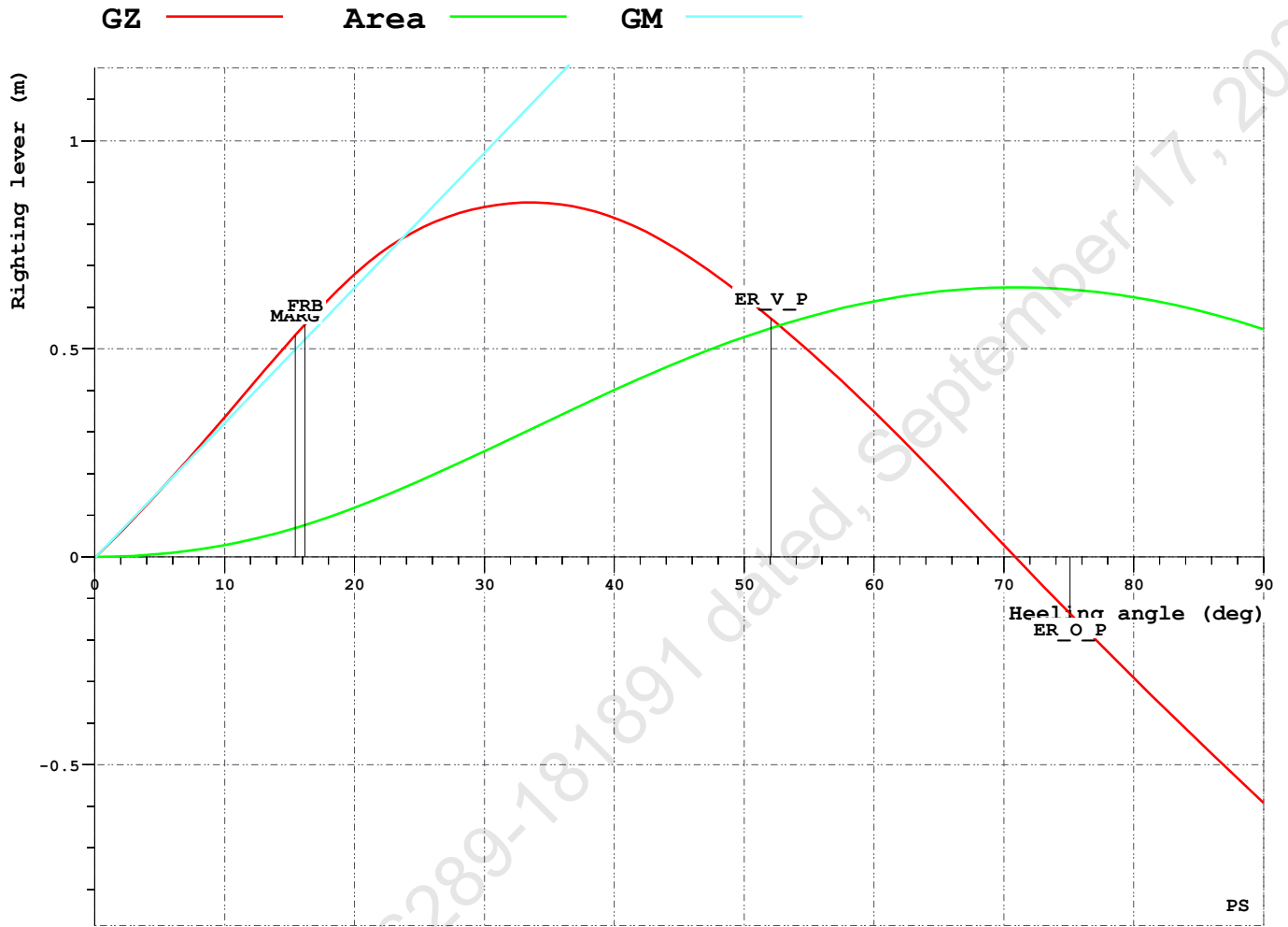

IMO WEATHER CRITERIA

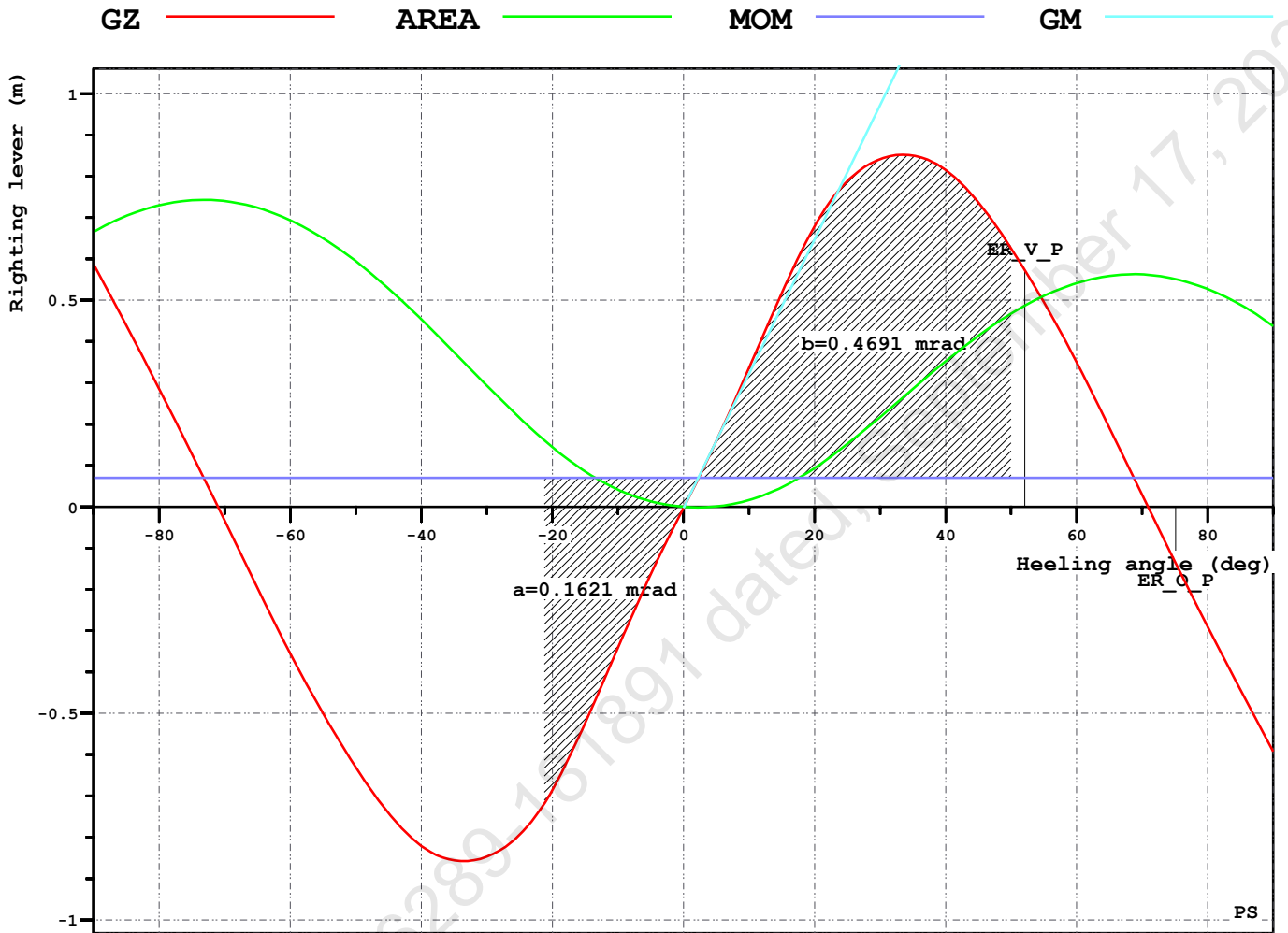

IS CODE LIFTING - Residual Area

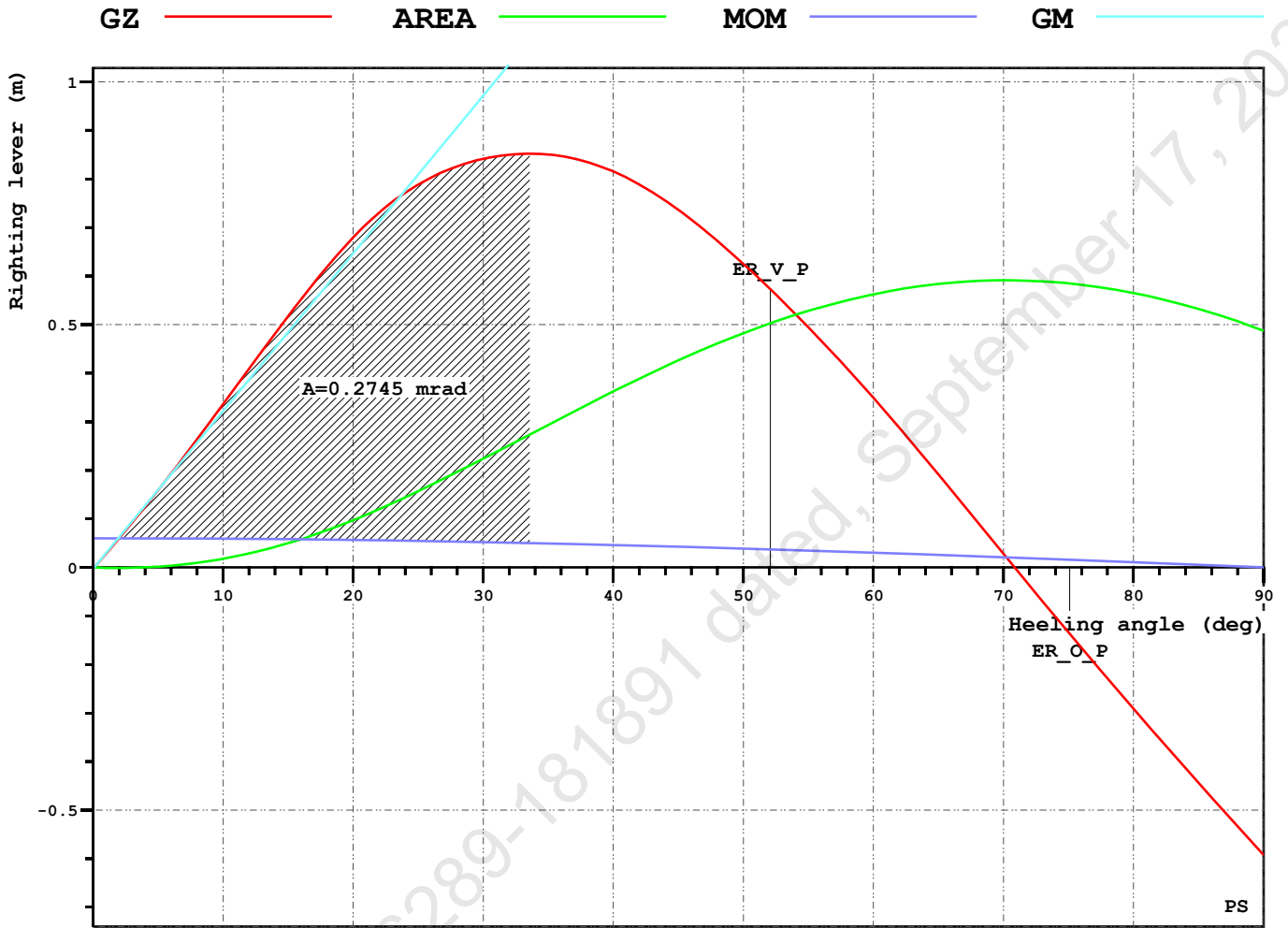

IS CODE LIFTING - Equilibrium angle

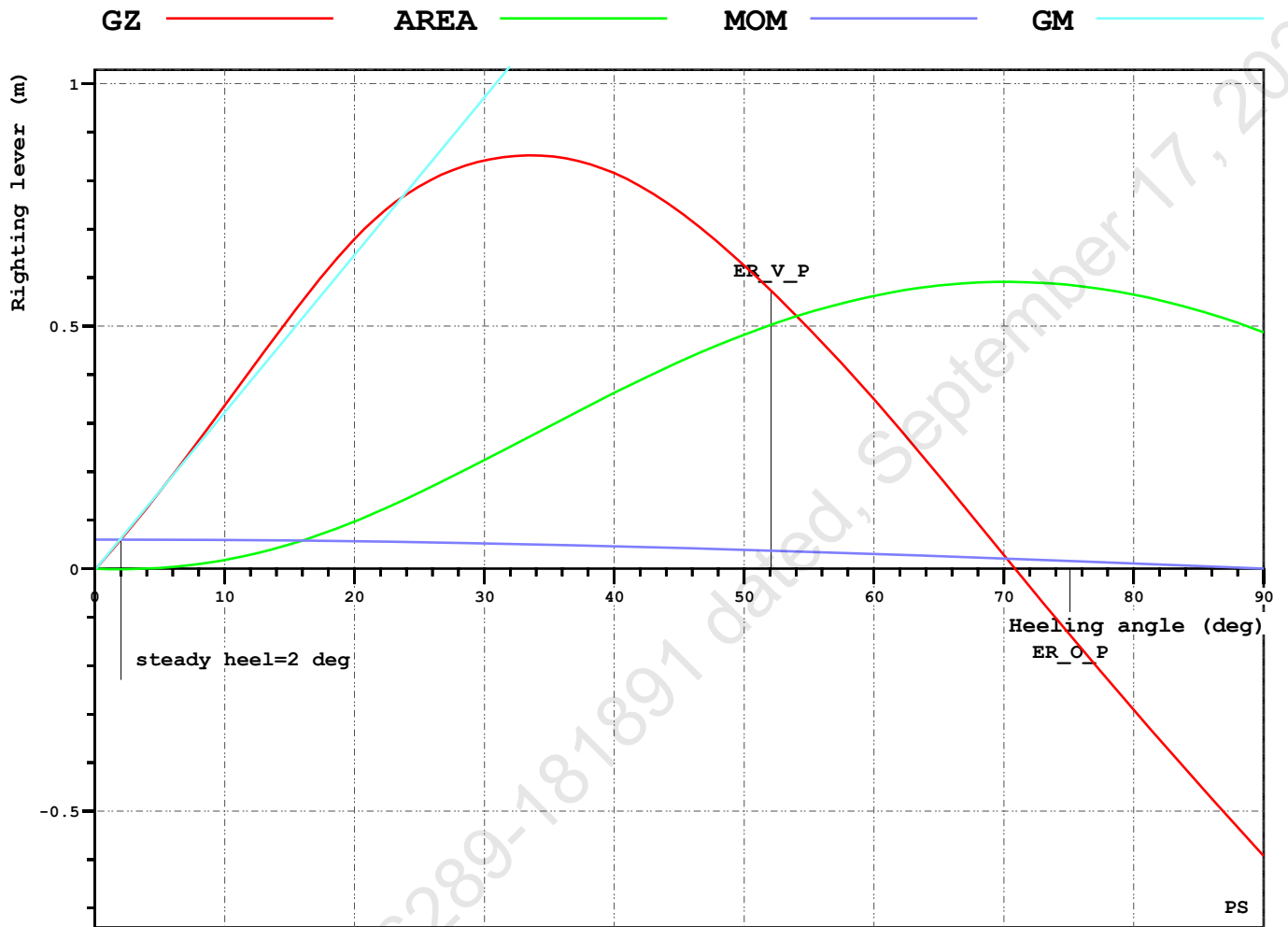

INTACT STABILITY CRITERIA

RCR	TEXT	REQ	ATTN UNIT	STAT
AREA30	Area under GZ curve up to 30 deg.	0.055	0.254 mrad	OK
AREA40	Area under GZ curve up to 40 deg.	0.090	0.401 mrad	OK
AREA3040	Area under GZ curve btw. 30-40 deg.	0.030	0.147 mrad	OK
GZ0.2	Max GZ > 0.2	0.200	0.852 m	OK
MAXGZ25	Max. GZ at an angle > 25 deg.	25.000	33.565 deg	OK
GM0.15	GM > 0.15 m	0.150	1.861 m	OK
V.IMOWEATHER	IMO weather criterion	1.000	2.894	OK
IMO.WIND_HEEL	Wind Heel <16 or <=80% of dk imm.	12.941	1.593 deg	OK
2020IS-B2.9.7.1.2	Eq. angle less than 10 deg. or dk. imm.	16.177	2.019 deg	OK
2020IS-B2.9.7.1.1	Resid. righting area > 0.08 mrad	0.080	0.274 mrad	OK

Refer IRS Letter E-126289-181897 dated, September 17, 2021

GZ CURVE DATA

HEEL deg	T m	TR m	GZ m	AREA mrad
0.0	3.699	-0.454	-0.003	0.000
0.1	3.699	-0.454	0.000	0.000
10.0	3.619	-0.418	0.336	0.028
20.0	3.381	-0.306	0.680	0.118
30.0	3.045	-0.343	0.841	0.254
40.0	2.605	-0.587	0.816	0.401
50.0	2.090	-0.880	0.625	0.529
60.0	1.526	-1.157	0.350	0.615
70.0	0.926	-1.389	0.028	0.648
80.0	0.320	-1.505	-0.291	0.624
90.0	-0.274	-1.641	-0.592	0.547

RELEVANT OPENINGS

NAME	TEXT	WT	X m	Y m	Z m	IMMA deg	IMMR m
ER_V_P	ER_INLET_P	UNPROTECTED	13.373	2.300	6.300	52.1	2.558
ER_V_S	ER_INLET_S	UNPROTECTED	13.373	-2.300	6.300	-	2.565
ER_O_P	ER_OUT_P	UNPROTECTED	14.000	1.500	8.400	75.1	4.668
ER_O_S	ER_OUT_S	UNPROTECTED	14.000	-1.500	8.400	-	4.673